

SIEMENS

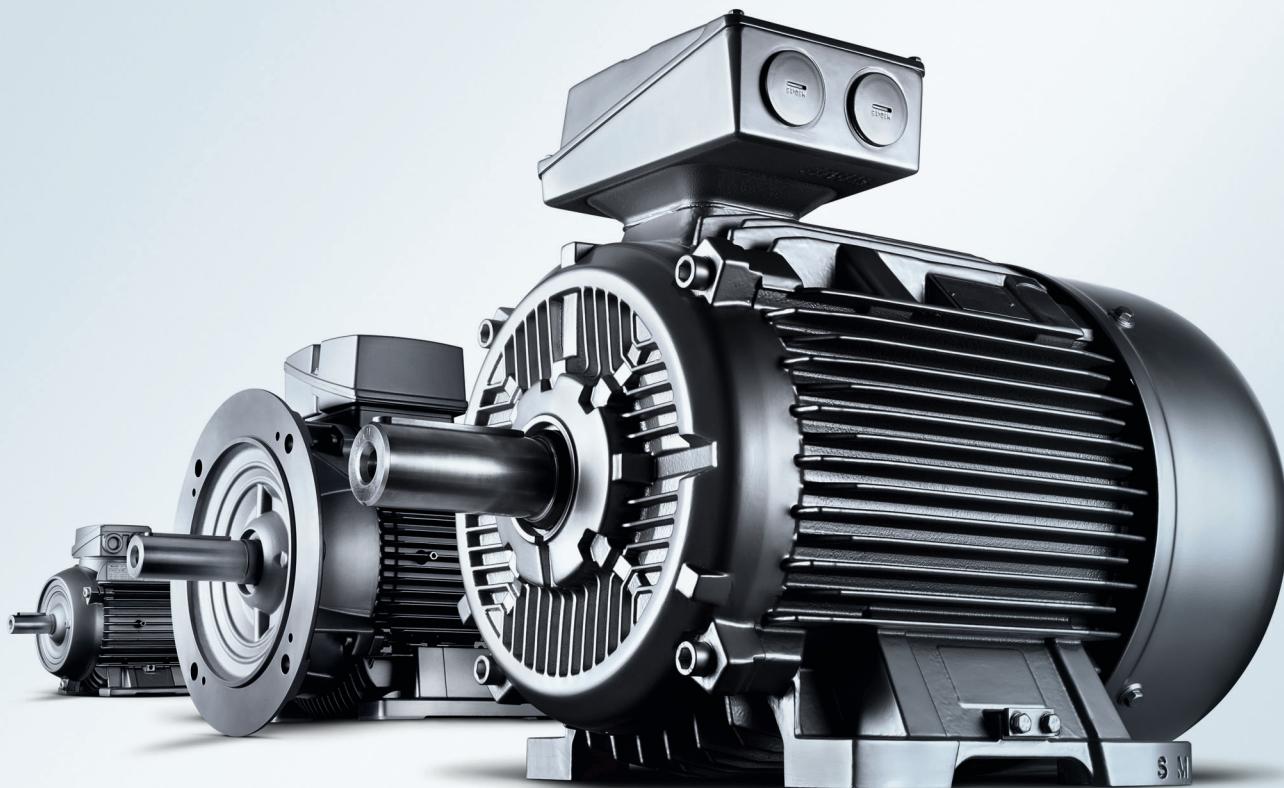

SIMOTICS Low-Voltage Motors

Distribution offering and 1LE0 option line

This technical brochure focuses on a selected motor spectrum specifically defined for the distribution business covering all main standard applications and industries

Edition
07/2014

Additional information is provided in the following documents and/or links:

- SIMOTICS Low-voltage Motors
Catalog D 81.1 · January 2012
Article No.: E86060-K5581-A111-A4-7600
Catalog D 81.1 · 2013
Article No.: E86060-K5581-A111-A6-7600
- SIMOTICS GP 1LE0 Low-voltage Motors
Catalog D 81.5N 09.2011
Article No.: E20001-K0369-C600-X-5D00
- Energy saving/Energy-saving program SinaSave
Further information regarding energy savings and the energy-saving program SinaSave can be found at the following internet addresses:
www.siemens.com/sinasave
www.siemens.com/energysaving
- Selection tool DT Configurator
The DT Configurator covers the product range of low-voltage motors and MICROMASTER 4 / SINAMICS inverters and converters as well as frequency converters for SIMATIC ET 200 distributed I/O. The range of available products is being continuously expanded.

The following information is provided for the individual products:
 - 2D/3D-model generator for motors and converters
 - Data sheet generator
 - Start-up calculation for motors
 - Comprehensive product-specific documentationwww.siemens.com/dt-configurator
- Additional documentation
You will find all information material, such as brochures, catalogs, manuals and operating instructions for standard drive systems up-to-date on the Internet at the address www.siemens.com/motors/printmaterial

You can order the listed documentation or download it in common file formats (PDF, ZIP).
- Further information about
Drive Systems > Variable-Speed Drives, e.g.,

SINAMICS and Motors for Single-Axis Drives	D 31
SINAMICS G130 Drive Converter Chassis Units	D 11
SINAMICS G150 Drive Converter Cabinet Units	
SINAMICS S120 Chassis Format Units and Cabinet Modules	D 21.3

can be obtained at
www.siemens.com/drives/infocenter

This brochure is only applicable in the following countries:

- ASEAN
 - Republic of Indonesia
 - Kingdom of Thailand
 - Malaysia
 - Socialist Republic of Vietnam
 - Republic of Singapore
 - Republic of the Philippines
 - Republic of Korea
- South America
 - Republic of Chile
 - Argentine Republic
- Middle East
 - United Arab Emirates
 - Kingdom of Saudi Arabia
 - Islamic Republic of Pakistan
- Africa
 - Republic of South Africa
- South Asia
 - People's Republic of Bangladesh

Content

Introduction	4
General overview	4
SIMOTICS Distribution Motors	
Key features	6
Special features	7
Applicable standards and specifications	9
Motor selection	10
Motor selection and article number structure	10
Type of construction	17
SIMOTICS General Purpose – Aluminum series (400 V)	
IE1 Efficiency	18
IE2 Efficiency	19
SIMOTICS General Purpose – Cast Iron series (400 V)	
IE1 Efficiency	20
IE2 Efficiency	23
SIMOTICS General Purpose – Cast Iron series (525 V)	
IE1 Efficiency	26
IE2 Efficiency	28
Distribution Motor Options	30
Special features detail	34
Efficiency	34
IP rating	36
Thermal class	37
Derating	38
Anti-condensation	39
Motor protection	40
Converter-fed application	41
Noise	44
Bearing	46
Terminal box	54
1LE0 option line	56
1LE0 option line	56
Product highlights	57
Article number explanation	59
List of options	60
Dimensional drawings	62
Aluminum series – 1LA7	64
Aluminum series – 1LE10	64
Cast Iron series – 1LE0	66
Flange dimensions	
Aluminum series – 1LA7	68
Aluminum series – 1LE10	69
Cast Iron series – 1LE0	69
User parts	70
Handling and storage	76
Certificates	76



Introduction

General overview

SIMOTICS – The name for the widest range of motors in the world

With 150 years of experience, we have driven motor technology forward, optimized them and played a decisive role in defining them.

Based on over 150 years of experience Siemens offers with SIMOTICS the most comprehensive range of motors for industrial applications proven with more than 40 million Siemens motors and drives installed around the world.

Our low-voltage motors meet the latest efficiency standards and stand for highest quality, reliability and compactness. Our motors are optimally integrated into the drive train. They are perfectly harmonized for the use with SIRIUS motor starters and SINAMICS frequency converters.

Our foundation of outstanding quality is the unparalleled experience from numerous Siemens production facilities around the world and close to our customers. This is how our experience drives your success!

Siemens is present in more than 190 countries around the world and a true local global player. We manufacture locally serving the individual markets. All of our products are based on one common global quality and design standard derived from our German engineering roots adapted to global market requirements.

We are present in your local market, understand your market's needs and also comply with local requirements and standards.

Let us show you how our experience and our partnership will drive your success with a new motors series specifically defined for the distribution business.

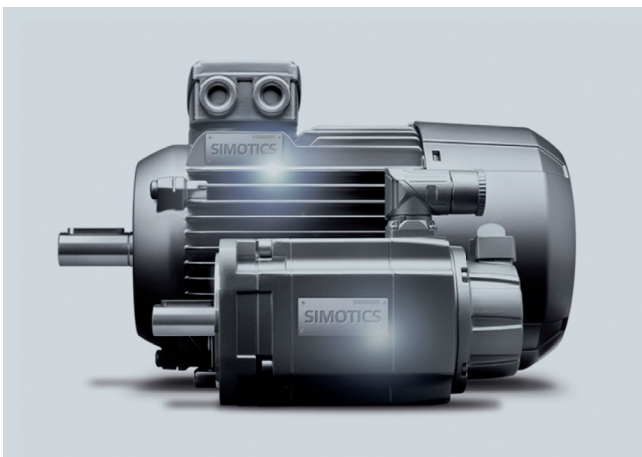

SIMOTICS low-voltage motors

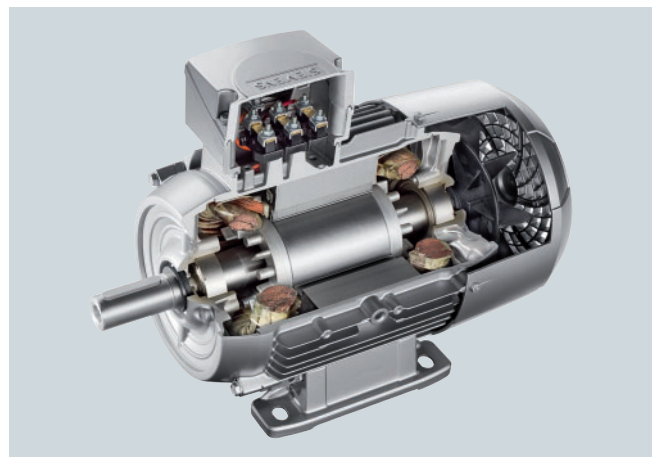

Cut-away aluminum motor



This brochure is using all of our 150 years experience and focuses on our SIMOTICS low-voltage IEC motors, especially defined for the distribution market. It covers both Aluminum and Cast Iron series motors for general purpose. Additional offering is always available from our standard motor catalog portfolio. We comply with the latest efficiency standards and describe motors for both the IE1 and IE2 efficiencies.

Although Siemens also has ranges for IE3 and specific solutions for IE4 efficiency, these are still considered specialized and are not described in this document. In addition to these general IE1 and IE2 solutions, Siemens can also provide specific variants for specific markets i.e. in India, Korea, China etc. In such instances please consult your local Siemens representative.

Our motor offering for the distribution market already includes the most common features required in your local market and country, e.g. drain holes, embedded PTCs and more.



IE1 Aluminum Motor (1LE10 & 1LA7)

- Frame size: 63 – 160
- Rated output: 0.12 – 18.5 kW
- No. of poles: 2, 4 and 6
- Voltage & frequency: 400 V \pm 5%, 50 Hz and other voltages and frequencies
- Type of construction: IM B3 and other types of construction

IE2 Aluminum Motor (1LE10)

- Frame size: 80 – 160
- Rated output: 0.55 – 18.5 kW
- No. of poles: 2, 4 and 6
- Voltage & frequency: 400 V \pm 5%, 50 Hz and other voltages and frequencies
- Type of construction: IM B3 and other types of construction



IE1 Cast Iron Motor (1LE0)

- Frame size: 80 – 355
- Rated output: 0.55 – 315 kW
- No. of poles: 2, 4 and 6
- Voltage & frequency: 400 V \pm 5%, 50 Hz and other voltages and frequencies
- Type of construction: IM B3 and other types of construction

IE2 Cast Iron Motor (1LE0)

- Frame size: 80 – 355
- Rated output: 0.55 – 315 kW
- No. of poles: 2, 4 and 6
- Voltage & frequency: 400 V \pm 5%, 50 Hz and other voltages and frequencies
- Type of construction: IM B3 and other types of construction

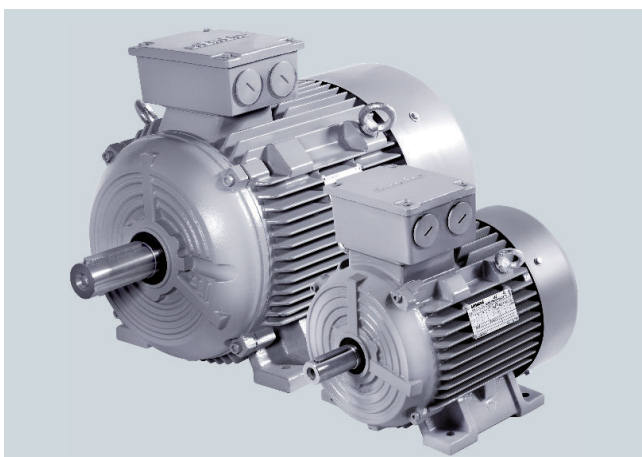

SIMOTICS 1LE0 Cast Iron motor

SIMOTICS Distribution Motors – Key features

In order to maximize inventory turn rates, minimize complexity, decrease stock levels and minimize your investment required, we defined a specific distribution portfolio already including most common required features as standard. In addition we offer an additional selection of options with which you can modify the distribution offering even more.

Besides we can always offer you the most comprehensive motor portfolio made to order for all applications and industries available from our standard catalog portfolio D 81.1 and SIMOTICS GP 1LE0 Low-voltage Motors catalog offering D 81.5N 09-2011.

The low-voltage motor unique key features:

1. Low vibration

The low vibration results from our precision manufacturing and the use of defined and controlled quality components. The quality bearings used augment this and result in longer life and lower noise. See chapter 1 – Applicable standards and specifications for details.

2. Drain hole as standard (1LE0)

Drain holes as standard make sure condensed water does not stay inside of the motor. This is especially important in humid environment and big temperature deltas.

3. Bearing for high cantilever forces and longer lifetime

Bearings in our motors are not only designed for high cantilever forces, but also to make sure the motors run smooth.

4. True IP55 as standard

Our IP55 design covers a vast majority of applications and is tested and proven for full lifetime, plus you have the full modification possibility within IP55 rating.

5. F to B thermal class for built-in reserve

The Siemens motors are rated at normal sinusoidal voltage with a class B (130 °C) temperature rise. The windings are rated to class F (155 °C) thus allowing for reserve for the additional losses associated with variable speed drive operation and / or higher ambient temperature and / or overload conditions when operating directly on-line. F to F is possible for converter-fed operation.

6. Converter-fed operation for variable speed as standard

For all motors offered up to 460 V converter-fed operation is possible as standard configuration – no special option or series is needed.

7. Embedded thermal protection 3x PTC (1LE0/1LA7 and 1LE1 motors)

Thermal protection with PTC thermistors with 3 embedded temperature sensors for tripping is provided in our IE2 motors above frame size 112 as standard version.

8. Global motor platform

Our motor design is based on one global motor platform with the same look and feel on all low-voltage motor IEC products.

9. Prepared for easy modification and mount auxiliaries

Our distribution motors are equipped with metal fan cover and center hole on non-drive end shaft for easy modification and mount auxiliaries.

For details on the above mentioned key features, please see chapter 3 "Special features detail".

SIMOTICS Distribution Motors – Special features

SIMOTICS General Purpose						
Efficiency class	Aluminum Series			Cast Iron Series		
	IE1		IE2	IE1	IE2	
	Series	1LA7	1LE1002	1LE1001	1LE0102	1LE0101
1	Low vibration	<input type="checkbox"/>	<input type="checkbox"/>	<input type="checkbox"/>	<input type="checkbox"/>	<input type="checkbox"/>
2	Drain hole as the standard	<input checked="" type="checkbox"/>	<input checked="" type="checkbox"/>	<input checked="" type="checkbox"/>	<input type="checkbox"/>	<input type="checkbox"/>
3	Bearing for high cantilever forces and longer lifetime	<input type="checkbox"/>	<input type="checkbox"/>	<input type="checkbox"/>	<input type="checkbox"/>	<input type="checkbox"/>
4	IP55 as the standard	<input type="checkbox"/>	<input type="checkbox"/>	<input type="checkbox"/>	<input type="checkbox"/>	<input type="checkbox"/>
5	F to B thermal class	<input type="checkbox"/>	<input type="checkbox"/>	<input type="checkbox"/>	<input type="checkbox"/>	<input type="checkbox"/>
6	Converter-fed operation for variable torque	<input type="checkbox"/>	<input type="checkbox"/>	<input type="checkbox"/>	<input type="checkbox"/>	<input type="checkbox"/>
7	Embedded thermal protection 3xPTC	<input checked="" type="checkbox"/>	<input checked="" type="checkbox"/>	<input checked="" type="checkbox"/>	<input checked="" type="checkbox"/>	<input type="checkbox"/>
8	Global motor platform	<input type="checkbox"/>	<input type="checkbox"/>	<input type="checkbox"/>	<input type="checkbox"/>	<input type="checkbox"/>
9	Prepared for easy modification and auxiliary mounting	-	<input checked="" type="checkbox"/>	<input checked="" type="checkbox"/>	-	<input type="checkbox"/>

- = Standard
- = Option in distribution portfolio
- = Not available

		63	71	80	90	100	112	132	160	180	200	225	250	280	315	355	Series	
Aluminum	Standard Efficiency IE1	1LA7 0.09 ... 2.2 kW																1
						1LE1002 1.5 ... 18.5 kW												2
	High Efficiency IE2					1LE1001 0.37 ... 18.5 kW												3
Cast Iron	Standard Efficiency IE1					1LE0102									0.55 ... 315 kW			4
	High Efficiency IE2					1LE0101									0.55 ... 315 kW			5

Did you know

- An oversized motor is seldom recommended, it normally has disadvantages including:
- Higher cost in investment and operation
 - A higher current resulting from a poorer power factor
 - A bigger frame size and extended dimensions.

SIMOTICS Distribution Motors – Special features

SIMOTICS General Purpose						
Efficiency class		Aluminum Series			Cast Iron Series	
		IE1		IE2	IE1	IE2
		1LA7	1LE1002	1LE1001	1LE0102	1LE0101
Voltage and frequency	Standard	400 V ± 5%	400 V ± 5%	400 V ± 5%	400 V ± 5%	400 V ± 5%
	Optional voltage @ 50 Hz	380 V, 415 V, 525 V	380 V, 415 V, 525 V	380 V, 415 V, 525 V	380 V, 415 V, 525 V	380 V, 415 V, 525 V
	Converter-fed operation ^(a)	□	□	□	□	□
Type of construction	Standard	IM B3	IM B3	IM B3	IM B3	IM B3
	Optional	IM B35, IM B5, IM V1, IM B14	IM B35, IM B5, IM V1, IM B14	IM B35, IM B5, IM V1, IM B14	IM B35, IM B5, IM V1, IM B14	IM B35, IM B5, IM V1, IM B14
Bearing designation	Bearing 62 C	□	□	□	□ ^(b)	□ ^(b)
	Bearing 63 C	–	◇	◇	□ ^(b)	□ ^(b)
Others	Metal fan cover	□	✓	✓	□	□
	Metal rating plate	□	–	–	□	□
	Drain hole	◇	◇	◇	□ ^(b)	□ ^(b)
	Center hole at non-drive end prepared for auxiliary mountings	–	✓ ^(b)	✓	–	□ ^(b)
	Space heater	✓	✓	✓	✓	✓
Motor protection	3 x PTC	✓	✓	✓	✓	□ ^(b)
Certificate	Extra rating plate for voltage tolerance	✓	✓	✓	□	□
	CE marking	–	–	□	–	□
	Routine test	✓	✓	✓	✓	✓
Standard color	Stone grey (RAL 7030)	□	□	□	□	□

□ = Standard

✓ = Option in distribution portfolio

◇ = Not available in distribution portfolio, only from standard catalog

– = Not available

^(a) = The limit for converter-fed operation is $460 V_{rms} + 10\%$.

^(b) = Depending on frame size and/or number of poles, please see respective sections.

TIP

All motors up to 460 V can be operated either directly on line or converter-fed – without the need for any additional measures. Both is possible as standard.

TIP

On our SIMOTICS GP 1LE0 motors we have an additional sticker mentioning voltage deviation as standard. On our other product line, deviations should be mentioned, please add option code B07.

TIP

All our motors are shown as 400 V as the nominal standard. The IEC 60034 regulations state that the nameplate data is only valid at the specific given voltage. In practice, all listed 400 V motors may be used at connection voltages $400 V \pm 5\%$. The motors will function well, although there would be deviations from the nominal electrical nameplate data. All 1LE0 motors will have a sticker in addition on the cowl as standard giving the nominal connection voltage as $400 V \pm 5\%$. According to the standard, motors can also be operated at $400 V \pm 10\%$ (Category B), only longer operation is not recommended.

Applicable standards and specifications

Title	IEC
Efficiency classes and efficiencies	IEC 60034-30:2008
Rotating electrical machines – Part 1: Rating and performance	IEC 60034-1
Rotating electrical machines – Part 2-1: Standard methods for determining losses and efficiency from tests (excluding machines for traction vehicles)	IEC 60034-2
Rotating electrical machines – Part 5: Degrees of protection provided by the integral design of rotating electrical machines (IP code) – Classification	IEC 60034-5
Rotating electrical machines – Part 6: Methods of cooling (IC Code)	IEC 60034-6
Rotating electrical machines – Part 7: Classification of types of construction, mounting arrangements and terminal box position (IM Code)	IEC 60034-7
Rotating electrical machines – Part 8: Terminal markings and direction of rotation	IEC 60034-8
Rotating electrical machines – Part 9: Noise limits	IEC 60034-9
Rotating electrical machines – Part 14: Mechanical vibration of certain machines with shaft heights 56 mm and higher – Measurement, evaluation and limits of vibration severity	IEC 60034-14
Rotating electrical machines – Part 1: Frame numbers 56 to 400 and flange numbers 55 to 1080	IEC 60072-1
Electrical insulation – Thermal classification	IEC 60085
Classification of environmental conditions Part 2-1: Environmental conditions appearing in nature – Temperature and humidity	IEC 60721-2-1
Standard voltages	IEC 60038

IEC 60034-1 differentiates between Category A (combination of voltage deviation $\pm 5\%$ and frequency deviation $\pm 2\%$) and Category B (combination of voltage deviation $\pm 10\%$ and frequency deviation $+3\% / -5\%$) for voltage and frequency fluctuations.

The motors can supply their rated torque in both Category A and B. In Category A, the temperature rise is approximately 10 K higher than during normal operation.

Standard 60034-1	Category A	Category B
Voltage deviation	$\pm 5\%$	$\pm 10\%$
Frequency deviation	$\pm 2\%$	$3\% / -5\%$
Rating plate data stamped with rated voltage a (e.g. 230 V)	a $\pm 5\%$ (e.g. 230 V $\pm 5\%$)	a $\pm 10\%$ (e.g. 230 V $\pm 10\%$)
Rating plate data stamped with rated voltage ranges b to c (e.g. 220 V to 240 V)	b -5 % to c +5 % (e.g. 220 V -5 % to 240 V +5 %)	b -10 % to c +10 % (e.g. 220 V -10 % to 240 V +10 %)

Rotors are dynamically balanced with half key. This corresponds to vibration quantity level A.

Tolerance for electrical data

- Efficiency η at
 $P_{\text{rated}} \leq 150 \text{ kW}$: $-0.15 \times (1 - \eta)$
 $P_{\text{rated}} > 150 \text{ kW}$: $-0.10 \times (1 - \eta)$
 With η being a decimal number
- Power factor $- (1 - \cos \varphi) / 6$
 Minimum absolute value: 0.02
 Maximum absolute value: 0.07
- Slip $\pm 20\%$ (for motors $< 1 \text{ kW}$ $\pm 30\%$ is admissible)
- Locked-rotor current $+20\%$
- Locked-rotor torque -15% to $+25\%$
- Breakdown torque -10%
- Moment of inertia $\pm 10\%$

Limits (rms values) for max. vibration quantity of vibration distance (s), vibration speed (v) and acceleration (a) for the shaft height H										
Vibration quantity level	Machine installation	Shaft height H in mm								
		$56 \leq H \leq 132$			$132 < H \leq 280$			$H > 280$		
		s_{rms} μm	v_{rms} mm/s	a_{rms} mm/s^2	s_{rms} μm	v_{rms} mm/s	a_{rms} mm/s^2	s_{rms} μm	v_{rms} mm/s	a_{rms} mm/s^2
A	Free suspension	25	1.6	2.5	35	2.2	3.5	45	2.8	4.4
	Rigid clamping	21	1.3	2.0	29	1.8	2.8	37	2.3	3.6
B	Free suspension	11	0.7	1.1	18	1.1	1.7	29	1.8	2.8
	Rigid clamping	–	–	–	14	0.9	1.4	24	1.5	2.4

Motor selection

Motor selection and article number structure

Here is our comprehensive distribution motor portfolio, offering both Aluminum and Cast Iron series IE1 and IE2 efficiency. Our portfolio is covering power ratings from 0.09 kW up to 315 kW and frame sizes 63 to 355.

SIMOTICS General Purpose										
Aluminum Series										
Efficiency class	IE1						IE2			
Series	1LA7			1LE1002			1LE1001			
No. of poles	2	4	6	2	4	6	2	4	6	
Cooling	Self-ventilated (IC 411)			Self-ventilated (IC 411)			Self-ventilated (IC 411)			
Degree of protection	IP55			IP55			IP55			
Insulation	Thermal class 155(F)			Thermal class 155(F)			Thermal class 155(F)			
Utilization	Thermal class 130(B)			Thermal class 130(B)			Thermal class 130(B)			
Frame size	63 ... 90			100 ... 160			80 ... 160			
Rated output at 50 Hz	0.09 ... 2.2 kW			1.5 ... 18.5 kW			0.37 ... 18.5 kW			
Rated torque at 50 Hz	0.61 ... 11 Nm			10 ... 109 Nm			2.6 ... 108 Nm			
Rated power (kW)	0.09	-	-	✓	-	-	-	-	-	-
0.12	-	✓	-	-	-	-	-	-	-	-
0.18	✓	✓	✓	-	-	-	-	-	-	-
0.25	✓	✓	✓	-	-	-	-	-	-	-
0.37	✓	✓	✓	-	-	-	-	-	-	✓
0.55	✓	✓	✓	-	-	-	-	✓	✓	✓
0.75	✓	✓	✓	-	-	-	✓	✓	✓	✓
1.1	✓	✓	✓	-	-	-	✓	✓	✓	✓
1.5	✓	✓	-	-	-	✓	✓	✓	✓	✓
2.2	✓	-	-	-	✓	✓	✓	✓	✓	✓
3	-	-	-	✓	✓	✓	✓	✓	✓	✓
4	-	-	-	✓	✓	✓	✓	✓	✓	✓
5.5	-	-	-	✓	✓	✓	✓	✓	✓	✓
7.5	-	-	-	✓	✓	✓	✓	✓	✓	✓
11	-	-	-	✓	✓	✓	✓	✓	✓	✓
15	-	-	-	✓	✓	-	✓	✓	-	-
18.5	-	-	-	✓	-	-	✓	-	-	-

✓ = Available
- = Not available

Did you know



Aluminum is a better conductor of heat than Cast Iron. For this reason Aluminum motors can feel warmer – keeping the inside cooler. Cast Iron may feel colder on the outside but the motor is sweating more on the inside.

General note:

All data shown in this brochure is reflecting 50 Hz data if not otherwise specified.



Did you know

All our described motors have a repeated starting capability.

Those motors used on a frequency converter ramping quickly from 0 Hz do not overheat and have an unlimited starting capability. (also see section “converter-fed application”)

Those motors started direct on-line heat slightly each time they start. The number of starts can only be calculated if many parameters are known.

As a rule, three successive normal starts for a cold motor and two successive starts for a warm motor are accepted.

SIMOTICS General Purpose						
Cast Iron Series						
Efficiency class	IE1			IE2		
Series	1LE0102			1LE0101		
No. of poles	2	4	6	2	4	6
Cooling	Self-ventilated (IC 411)			Self-ventilated (IC 411)		
Degree of protection	IP55			IP55		
Insulation	Thermal class 155(F)			Thermal class 155(F)		
Utilization	Thermal class 130(B)			Thermal class 130(B)		
Frame size	80 ... 355			80 ... 355		
Rated output at 50 Hz	0.55 ... 315 kW			0.55 ... 315 kW		
Rated torque at 50 Hz	2.6 ... 2414 Nm			2.6 ... 2412 Nm		
Rated power (kW)						
0.55	–	✓	✓	–	✓	✓
0.75	✓	✓	✓	✓	✓	✓
1.1	✓	✓	✓	✓	✓	✓
1.5	✓	✓	✓	✓	✓	✓
2.2	✓	✓	✓	✓	✓	✓
3	✓	✓	✓	✓	✓	✓
4	✓	✓	✓	✓	✓	✓
5.5	✓	✓	✓	✓	✓	✓
7.5	✓	✓	✓	✓	✓	✓
11	✓	✓	✓	✓	✓	✓
15	✓	✓	✓	✓	✓	✓
18.5	✓	✓	✓	✓	✓	✓
22	✓	✓	✓	✓	✓	✓
30	✓	✓	✓	✓	✓	✓
37	✓	✓	✓	✓	✓	✓
45	✓	✓	✓	✓	✓	✓
55	✓	✓	✓	✓	✓	✓
75	✓	✓	✓	✓	✓	✓
90	✓	✓	✓	✓	✓	✓
110	✓	✓	✓	✓	✓	✓
132	✓	✓	✓	✓	✓	✓
160	✓	✓	✓	✓	✓	✓
185	✓	✓	✓	✓	✓	✓
200	✓	✓	✓	✓	✓	✓
220	✓	✓	✓	✓	✓	✓
250	✓	✓	✓	✓	✓	✓
280	✓	✓	–	✓	✓	–
315	✓	✓	–	✓	✓	–

✓ = Available

– = Not available

Motor selection and article number structure

Besides the already embedded distribution features we offer an additional selection of options with which you can customize the distribution offering even more. The option range covers mainly different voltages and mounting types, mechanical design and many other commonly required features.

Note:

Please refer to chapter 2 for distribution motor option selection.



Did you know

Motors can be offered with anti-condensation heating as an option. Retrofitting of small motors is not so easy. An alternative is to switch one delta-winding or two star-winding connections across a lower voltage supply. The motor cannot turn and is heated. The voltage should be selected at ~10% of the nominal.

Aluminum	Series	Frame size availability	
SIMOTICS GP 1LA7 Standard Efficiency IE1	1		
SIMOTICS GP 1LE10 Standard Efficiency IE1	2		
SIMOTICS GP 1LE10 High Efficiency IE2	3		
Cast Iron			
SIMOTICS GP 1LE0102 Standard Efficiency IE1	4		
SIMOTICS GP 1LE0101 High Efficiency IE2	5		
		63	71
Voltage and frequency			
400 V, 50 Hz		☐	☐
380 V, 50 Hz		✓	✓
415 V, 50 Hz		✓	✓
525 V, 50 Hz		✓	✓
Type of construction			
IM B3		☐	☐
IM B35		✓	✓
IM B5		✓	✓
IM V1 ^(a)		✓	✓
IM B14		✓	✓
Mechanical design and degrees of protection			
Condensation drain holes		◇	◇
Drive-end seal for flange-mounting motors, oil-tight to 0.1 bar		✓	✓
Heating and ventilation			
Anti-condensation heating for 230 V		✓	✓
Anti-condensation heating for 115 V		✓	✓
Motor protection			
Motor protection with PTC thermistors with 1 (for motors 1LE10 FS 80 and 90) or 3 embedded temperature sensors for tripping		✓	✓
Bearing and lubrication			
Bearing design for increased cantilever forces		–	–
Regreasing device		–	–
Packing, safety notes, documentation and certificate			
Extra rating plate for voltage tolerance		✓	✓
Acceptance test certificate 3.1 in accordance with EN 10204 (routine test)		✓	✓
CE marking		–	–
Sea-worthy packing for export		☐	☐

☐ = Standard

✓ = Option in distribution portfolio

◇ = Not available in distribution portfolio, only from standard catalog

– = Not available

^(a) = For canopy as modification, please see chapter 5

^(b) = Depends on frame size or number of poles, please see respective sections

^(c) = Only for IE2 motors

	80	90	100	112	132	160	180	200	225	250	280	315	355
	□	□	□	□	□	□	□	□	□	□	□	□	□
	✓	✓	✓	✓	✓	✓	✓	✓	✓	✓	✓	✓	✓
	✓	✓	✓	✓	✓	✓	✓	✓	✓	✓	✓	✓	✓
	✓	✓	✓	✓	✓	✓	✓	✓	✓	✓	✓	✓	✓
	□	□	□	□	□	□	□	□	□	□	□	□	□
	✓	✓	✓	✓	✓	✓	✓	✓	✓	✓	✓	✓	✓
	✓	✓	✓	✓	✓	✓	✓	✓	✓	✓	✓	✓	-
	✓	✓	✓	✓	✓	✓	✓	✓	✓	✓	✓	✓	✓
	✓	✓	✓	✓	✓	✓	-	-	-	-	-	-	-
	◇	◇	◇	◇ 2, 3 □ 4, 5	◇ 2, 3 □ 4, 5	◇ 2, 3 □ 4, 5	□	□	□	□	□	□	□
	✓ -4, 5	✓ -4, 5	✓ -4, 5	✓ -4, 5	✓ -4, 5	✓ -4, 5	-	-	-	-	-	-	-
	✓	✓	✓	✓	✓	✓	✓	✓	✓	✓	✓	✓	✓
	✓	✓	✓	✓	✓	✓	✓	✓	✓	✓	✓	✓	✓
	✓	✓	✓	✓	✓ 2, 3, 4 □ 5	✓ 2, 3, 4 □ 5	✓ 4 □ 5	✓ 4 □ 5	✓ 4 □ 5	✓ 4 □ 5	✓ 4 □ 5	✓ 4 □ 5	✓ 4 □ 5
	-	-	✓	✓ 2, 3, 4 □ 5 ^(b)	✓ 2, 3, 4 □ 5 ^(b)	✓ 2, 3, 4 □ 5 ^(b)	✓	✓	✓	✓	✓	✓	✓
	-	-	✓	✓	✓	✓	✓	✓	✓	✓	□	□	□
	✓ □ 4, 5	✓ □ 4, 5	✓ □ 4, 5	✓ □ 4, 5	✓ □ 4, 5	✓ □ 4, 5	□	□	□	□	□	□	□
	✓	✓	✓	✓	✓	✓	✓	✓	✓	✓	✓	✓	✓
	□ ^(c)	□ ^(c)	□ ^(c)	□ ^(c)	□ ^(c)	□ ^(c)	□ ^(c)	□ ^(c)	□ ^(c)	□ ^(c)	□ ^(c)	□ ^(c)	□ ^(c)
	□	□	□	□	□	□	□	□	□	□	□	□	□

Motor selection and article number structure · 12 digits

Overview

The article number consists of a combination of figures and letters and is divided into two blocks linked with hyphens for a better overview.

The first block (Position 1 to 7) identifies motor type and motor frame size; and the second block defines number of poles, frequency/output and type of construction.

Structure of Article No. (1LA7 series)

Structure	Position: 1 2 3 4 5 6 7 - 8 9 10 11 12 - Z
<u>Position 1 to 4:</u>	Low-voltage motor series • IE1 Aluminum motor 1 L A 7
<u>Position 5 to 7:</u>	Frame size (frame size comprising shaft height and construction length) • 060 • 063 • 070 • 073 • 080 • 083 • 090 • 096
<u>Position 8:</u>	Number of poles • 2 • 4 • 6
<u>Position 9 to 10:</u>	Version • AA • AB
<u>Position 11:</u>	Voltage, circuit and frequency • 6 = 400 VD 50 Hz • 9 ^(a) = special voltage & frequency ^(b)
<u>Position 12:</u>	Type of construction • 0 = IM B3 • 6 = IM B35 • 1 = IM B5 • 1 = IM V1 • 2 = IM B14
	Special order version Coded - Order (option) code also required ^(a)

^(a) For deviations in the second and third block from the catalog codes, either **-Z** or **9** should be used as appropriate, e.g. 1LA7080-2AA60-Z Z=B02; or 1LA7080-2AA90 Z=L1C.

^(b) L1L for 380 V, 50 Hz; L1C for 415 V, 50 Hz.

Ordering example

Selection criteria	Requirement	Structure of the Article No.
Motor type	Aluminum motor IE1 efficiency	1LA7■■■■-■■■■■
Motor frame size / No. of poles / Speed	4-pole / 1500 rpm	1LA7080-4AA■■■
Rated output	0.55 kW	1LA7080-4AA6■
Voltage and frequency	400 V, 50 Hz	1LA7080-4AA60
Type of construction	IM B3	1LA7080-4AA60
Special versions	Anti-condensation heating for 230 V	1LA7080-4AA60-Z K45

Motor selection and article number

Name plates

1LA7 series

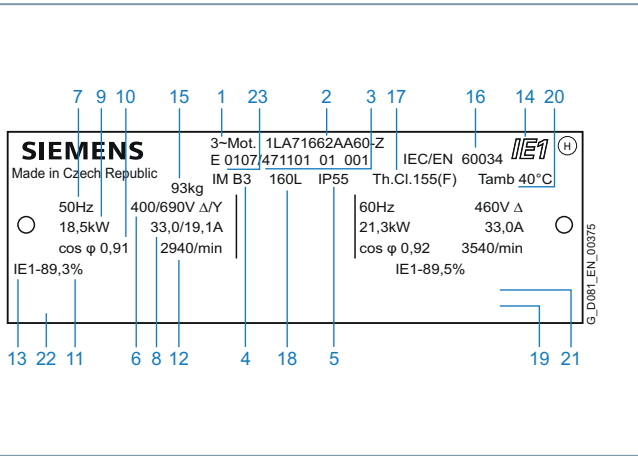

Legend:

- | | |
|---|--|
| 1 Three-phase low-voltage motor | 13 Efficiency class |
| 2 Article No. | 14 Balance method and efficiency class |
| 3 Factory number (Ident No., serial number) | 15 Machine weight [kg] |
| 4 Type of construction | 16 Standards and regulations |
| 5 Degree of protection | 17 Temperature class |
| 6 Rated voltage [V] and winding connections | 18 Frame size |
| 7 Frequency [Hz] | 19 Additional details (optional) |
| 8 Rated current [A] | 20 Operating temperature range (only if it deviates from normal) |
| 9 Rated output [kW] | 21 Site altitude (only when higher than 1000 m) |
| 10 Power factor [cos φ] | 22 Customer data (optional) |
| 11 Efficiency | 23 Date of manufacture YYMM |
| 12 Rated speed [rpm] | |

1LE10 series

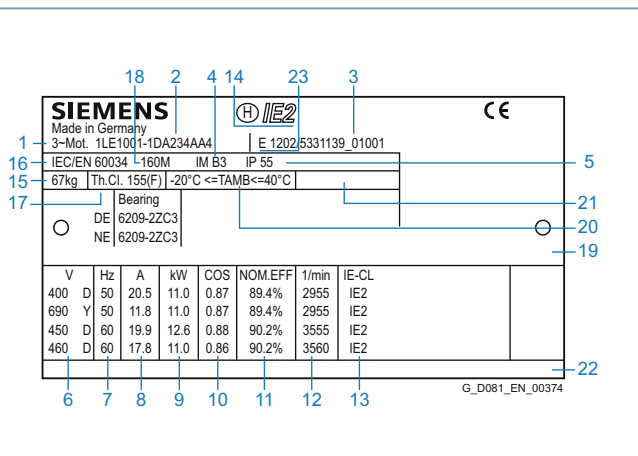

Legend:

- | | |
|---|--|
| 1 Three-phase low-voltage motor | 13 Efficiency class |
| 2 Article No. | 14 Balance method and efficiency class |
| 3 Factory number (Ident No., serial number) | 15 Machine weight [kg] |
| 4 Type of construction | 16 Standards and regulations |
| 5 Degree of protection | 17 Temperature class |
| 6 Rated voltage [V] and winding connections | 18 Frame size |
| 7 Frequency [Hz] | 19 Additional details (optional) |
| 8 Rated current [A] | 20 Operating temperature range (only if it deviates from normal) |
| 9 Rated output [kW] | 21 Site altitude (only when higher than 1000 m) |
| 10 Power factor [cos φ] | 22 Customer data (optional) |
| 11 Efficiency | 23 Date of manufacture YYMM |
| 12 Rated speed [rpm] | |

1LE0 series

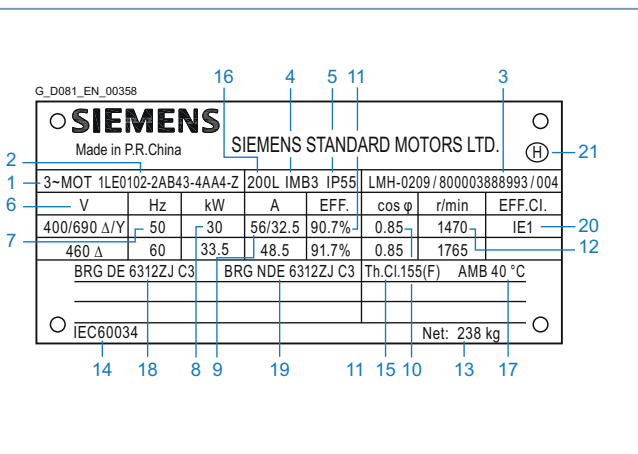

Legend:

- | | |
|---------------------------------|-----------------------------|
| 1 Three-phase low-voltage motor | 12 Rated speed |
| 2 Article No. | 13 Machine weight (kg) |
| 3 Series number | 14 Standards |
| 4 Type of construction | 15 Temperature class |
| 5 Degree of protection | 16 Frame size |
| 6 Rated voltage | 17 Ambient temperature |
| 7 Frequency (Hz) | 18 Bearing at drive end |
| 8 Rated output (kW) | 19 Bearing at non-drive end |
| 9 Rated current (A) | 20 Efficiency class |
| 10 Power factor (cos φ) | 21 Balance method |
| 11 Efficiency | |

Type of construction

In addition to the basic IM B3 type of construction, motors can also be supplied in other types of construction. We provide most commonly used type of constructions in our selection for you, as well as possibility for own modification.

The possible versions in our selection for a particular motor type can be taken from the table below.

Standard type of construction and special type of construction

Type of construction according to DIN EN 60034-7	Frame size	16 Digits Article No. 14th position of the Article No.	12 Digits Article No. 12th position of the Article No.
IM B3	63 to 355	A	0
IM B35	63 to 355	J	6
IM B5	63 to 315	F	1
IM V1	63 to 355	G	1
IM B14	63 to 160	K	2

Did you know?



When mounting the motors in diverse orientations consider the location of the drain hole – it must be at the lowest point to drain water.

Apart from the distribution portfolio covered mounting types, here is the general overview of the possible mounting types. Many of them can be achieved by modifying this offered portfolio. Anything else can still be supplied out of our standard catalog portfolio, see D 81.1

TIP

Mounting motors in orientations other than these intended could lead to mechanical or structural premature failure. If in any doubt, please consult your Siemens partner.

Types of construction

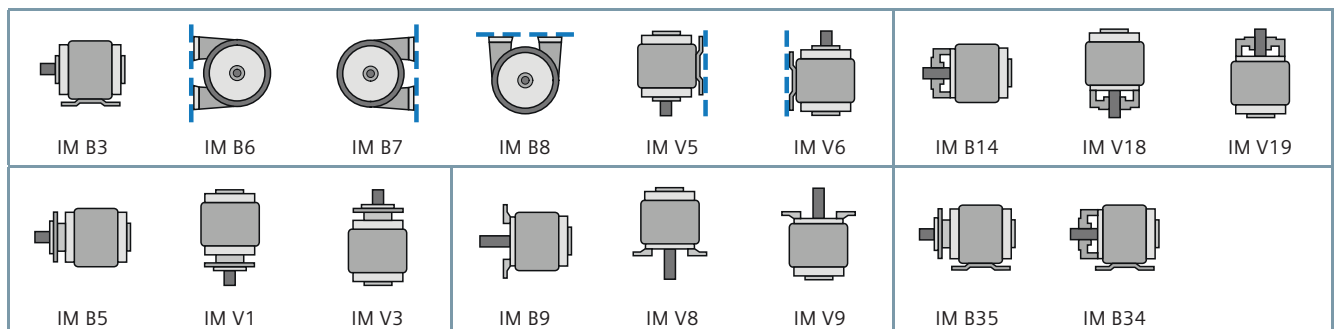

Types of construction according to DIN IEC 34, Part 7



The nominal torque of the motor is easy to calculate;
Torque (Nm) = Power (kW) x 9550 / Speed (rpm).

SIMOTICS General Purpose (Aluminum Series) – IE1

Aluminum Series									
Efficiency class	IE1						IE2		
Series	1LA7			1LE1002			1LE1001		
No. of poles	2	4	6	2	4	6	2	4	6
Cooling	Self-ventilated (IC 411)			Self-ventilated (IC 411)			Self-ventilated (IC 411)		
Degree of protection	IP55			IP55			IP55		
Insulation	Thermal class 155(F)			Thermal class 155(F)			Thermal class 155(F)		
Utilization	Thermal class 130(B)			Thermal class 130(B)			Thermal class 130(B)		
Frame size	63 ... 90			100 ... 160			80 ... 160		
Rated output at 50 Hz	0.09 ... 2.2 kW			1.5 ... 18.5 kW			0.37 ... 18.5 kW		
Rated torque at 50 Hz	0.61 ... 11 Nm			10 ... 109 Nm			2.6 ... 108 Nm		

Electrical data - 1LA7 & 1LE10 - IE1 - 2-pole (IE1 Aluminum) 3000 rpm 2-pole, 400 V 50 Hz																	
Rated output	Frame size	Article number	IE class	Rated speed	Rated torque	No load current	Rated current	Rated power factor	Efficiency at			Starting		Break-down torque	Moment of inertia	Torque class	Net weight (IMB3)
kW				rpm	Nm	A	A		100% load %	75% load %	50% load %	current	torque	Nm	kgm ²		kg
0.18	63M	1LA7060-2AA..	-	2820	0.61	0.43	0.51	0.82	62.0	60.5	56.0	3.7	2.0	2.2	0.00018	16	3.6
0.25	63M	1LA7063-2AA..	-	2830	0.84	0.60	0.70	0.82	63.0	62.0	57.0	4.0	2.3	2.2	0.00022	16	4.0
0.37	71M	1LA7070-2AA..	-	2740	1.3	0.86	0.99	0.82	66.0	65.0	61.0	3.5	2.5	2.3	0.00029	16	5.0
0.55	71M	1LA7073-2AA..	-	2800	1.9	1.12	1.36	0.82	71.0	71.0	67.0	4.3	2.3	2.6	0.00041	16	6.0
0.75	80M	1LA7080-2AA..	IE 1	2855	2.5	1.34	1.75	0.86	72.1	72.1	68.1	5.6	2.6	2.4	0.00079	16	9.0
1.1	80M	1LA7083-2AA..	IE 1	2845	3.7	1.47	2.45	0.87	75.0	75.0	72.0	6.1	2.4	2.7	0.0010	16	10.7
1.5	90S	1LA7090-2AA..	IE 1	2860	5.0	2.10	3.3	0.85	77.2	77.7	74.2	5.5	2.8	2.7	0.0014	16	13.0
2.2	90L	1LA7096-2AA..	IE 1	2880	7.3	2.30	4.7	0.85	79.7	79.7	78.7	6.3	2.8	3.1	0.0018	16	15.7
3	100L	1LE1002-1AA4-....4	IE 1	2835	10	2.77	6.1	0.87	81.5	82.8	82.1	6.2	3.2	2.9	0.0034	16	20
4	112M	1LE1002-1BA2-....4	IE 1	2930	13	4.15	8.1	0.86	83.1	83.8	82.2	7.3	2.7	3.7	0.0067	16	25
5.5	132S	1LE1002-1CA0-....4	IE 1	2905	18	4.37	10.5	0.89	84.7	85.7	85.0	5.6	1.9	2.5	0.013	16	35
7.5	132S	1LE1002-1CA1-....4	IE 1	2925	24	6.1	14.5	0.87	86.0	86.9	85.8	6.3	2.1	3.2	0.016	16	40
11	160M	1LE1002-1DA2-....4	IE 1	2925	36	9.13	21.5	0.85	87.6	87.6	86.1	5.8	2.0	2.6	0.030	16	60
15	160M	1LE1002-1DA3-....4	IE 1	2930	49	12.4	29	0.84	88.7	89.0	88.0	6.1	2.5	3.1	0.036	16	68
18.5	160L	1LE1002-1DA4-....4	IE 1	2935	60	13.38	35	0.86	89.3	90.0	89.7	7.0	2.5	3.2	0.044	16	78

Electrical data - 1LA7 & 1LE10 - IE1 - 4-pole (IE1 Aluminum) 1500 rpm 4-pole, 400 V 50 Hz																	
Rated output	Frame size	Article number	IE class	Rated speed	Rated torque	No load current	Rated current	Rated power factor	Efficiency at			Starting		Break-down torque	Moment of inertia	Torque class	Net weight (IMB3)
kW				rpm	Nm	A	A		100% load %	75% load %	50% load %	current	torque	Nm	kgm ²		kg
0.12	63M	1LA7060-4AB..	-	1350	0.85	0.40	0.43	0.75	53.6	52.1	47.6	2.8	1.9	2.0	0.00029	13	3.6
0.18	63M	1LA7063-4AB..	-	1350	1.3	0.52	0.58	0.77	58.3	56.8	52.3	3.0	1.9	1.9	0.00037	13	4.0
0.25	71M	1LA7070-4AB..	-	1350	1.8	0.72	0.75	0.78	61.9	60.4	55.9	3.0	1.9	1.9	0.00052	13	4.8
0.37	71M	1LA7073-4AB..	-	1370	2.6	0.93	1.04	0.78	65.8	64.8	60.8	3.3	1.9	2.1	0.00077	13	6.3
0.55	80M	1LA7080-4AA..	-	1395	3.8	1.30	1.41	0.81	69.4	69.4	65.4	3.9	2.2	2.2	0.0014	16	8.8
0.75	80M	1LA7083-4AA..	IE 1	1395	5.1	1.57	1.88	0.80	72.1	72.1	68.1	4.2	2.3	2.3	0.0017	16	10.0
1.1	90S	1LA7090-4AA..	IE 1	1415	7.4	2.00	2.6	0.81	75.0	75.0	72.0	4.6	2.3	2.4	0.0024	16	12.9
1.5	90L	1LA7096-4AA..	IE 1	1420	10	2.65	3.45	0.81	77.2	77.7	74.2	5.3	2.4	2.6	0.0033	16	15.5
2.2	100L	1LE1002-1AB4-....4	IE 1	1425	15	2.36	4.9	0.81	79.7	80.5	78.5	5.1	2.2	2.3	0.0059	16	18
3	100L	1LE1002-1AB5-....4	IE 1	1425	20	3.11	6.3	0.85	81.5	83.0	82.3	5.4	2.4	2.6	0.0078	16	22
4	112M	1LE1002-1BB2-....4	IE 1	1435	27	4.04	8.2	0.85	83.1	84.5	84.0	5.3	2.2	2.6	0.01	16	27
5.5	132S	1LE1002-1CB0-....4	IE 1	1450	36	6.04	11.2	0.82	84.7	85.7	84.9	5.7	2.3	2.7	0.019	16	38
7.5	132M	1LE1002-1CB2-....4	IE 1	1450	49	7.94	15.2	0.82	86.0	86.9	86.3	6.6	2.6	3.1	0.024	16	44
11	160M	1LE1002-1DB2-....4	IE 1	1460	72	12.40	22	0.82	87.6	88.0	86.6	6.4	2.3	3.1	0.044	16	62
15	160L	1LE1002-1DB4-....4	IE 1	1460	98	15.90	30	0.82	88.7	89.3	88.3	7	2.5	3.4	0.056	16	73

Electrical data - 1LA7 & 1LE10 - IE1 - 6-pole (IE1 Aluminum) 1000 rpm 6-pole, 400 V 50 Hz																	
Rated output	Frame size	Article number	IE class	Rated speed	Rated torque	No load current	Rated current	Rated power factor	Efficiency at			Starting		Break-down torque	Moment of inertia	Torque class	Net weight (IMB3)
kW				rpm	Nm	A	A		100% load %	75% load %	50% load %	current	torque	Nm	kgm ²		kg
0.09	63M	1LA7063-6AB..	-	850	1.0	0.46	0.39	0.66	50.2	48.7	44.2	2.0	1.8	1.9	0.00037	13	4.0
0.18	71M	1LA7070-6AA..	-	850	2.0	0.65	0.67	0.68	57.3	55.8	51.3	2.3	2.1	1.9	0.00055	16	4.8
0.25	71M	1LA7073-6AA..	-	860	2.8	0.71	0.77	0.76	61.9	60.4	55.9	2.7	2.2	2.0	0.00080	16	5.8
0.37	80M	1LA7080-6AA..	-	920	3.8	1.18	1.16	0.72	64.1	63.1	59.1	3.1	1.9	2.1	0.0014	16	8.6
0.55	80M	1LA7083-6AA..	-	910	5.8	1.45	1.59	0.74	67.5	67.0	63.5	3.4	2.1	2.2	0.0017	16	9.8
0.75	90S	1LA7090-6AA..	IE 1	915	7.8	1.63	2.05	0.76	70.0	70.0	66.0	3.7	2.2	2.2	0.0024	16	12.6
1.1	90L	1LA7096-6AA..	IE 1	915	11.0	2.15	2.85	0.77	72.9	72.9	69.9	3.8	2.3	2.3	0.0033	16	15.7
1.5	100L	1LE1002-1AC4-....4	IE 1	940	15	2.66	3.9	0.74	75.2	76.0	72.4	4	2	2.2	0.0065	16	19
2.2	112M	1LE1002-1BC2-....4	IE 1	930	23	3.43	5.4	0.75	77.7	78.8	76.9	4.1	2.3	2.5	0.0092	16	25
3	132S	1LE1002-1CC0-....4	IE 1	955	30	4.86	7.3	0.74	79.7	80.2	77.7	4.6	2	2.6	0.017	16	34
4	132M	1LE1002-1CC2-....4	IE 1	950	40	5.47	9.3	0.76	81.4	82.9	82.1	4.7	2.1	2.5	0.021	16	39
5.5	132M	1LE1002-1CC3-....4	IE 1	950	55	7.59	12.7	0.75	83.1	84.6	84.0	5.2	2.5	2.8	0.027	16	48
7.5	160M	1LE1002-1DC2-....4	IE 1	970	74	10.73	17.5	0.73	84.7	85.4	85.0	5.5	2.1	2.9	0.056	16	72
11	160L	1LE1002-1DC4-....4	IE 1	965	109	13.10	24	0.77	86.4	86.4	85.4	5.9	1.9	2.7	0.078	16	92

SIMOTICS General Purpose (Aluminum Series) – IE2

Aluminum Series									
Efficiency class	IE1						IE2		
Series	1LA7			1LE1002			1LE1001		
No. of poles	2	4	6	2	4	6	2	4	6
Cooling	Self-ventilated (IC 411)			Self-ventilated (IC 411)			Self-ventilated (IC 411)		
Degree of protection	IP55			IP55			IP55		
Insulation	Thermal class 155(F)			Thermal class 155(F)			Thermal class 155(F)		
Utilization	Thermal class 130(B)			Thermal class 130(B)			Thermal class 130(B)		
Frame size	63 ... 90			100 ... 160			80 ... 160		
Rated output at 50 Hz	0.09 ... 2.2 kW			1.5 ... 18.5 kW			0.37 ... 18.5 kW		
Rated torque at 50 Hz	0.61 ... 11 Nm			10 ... 109 Nm			2.6 ... 108 Nm		

Electrical data - 1LE10 - IE2 - 2-pole (IE2 Aluminum) 3000 rpm 2-pole, 400 V 50 Hz																	
Rated output kW	Frame size	Article number	IE class	Rated speed rpm	Rated torque Nm	No load current A	Rated current A	Rated power factor	Efficiency at			Starting		Break-down torque Nm	Moment of inertia kgm ²	Torque class	Net weight (IMB3) kg
									100% load %	75% load %	50% load %	current	torque				
0.75	80M	1LE1001-ODA2-...4	IE 2	2805	2.6	0.89	1.67	0.84	77.4	79.5	78.8	4.9	1.9	2.3	0.0008	16	9
1.1	80M	1LE1001-ODA3-...4	IE 2	2835	3.7	1.22	2.4	0.83	79.6	81.3	80.8	6	2.7	3.1	0.0011	16	11
1.5	90S	1LE1001-OEA0-...4	IE 2	2885	5	1.91	3.15	0.84	81.3	82.3	80.8	6.9	2.7	3.6	0.0017	16	13
2.2	90L	1LE1001-OEA4-...4	IE 2	2890	7.3	2.45	4.5	0.85	83.2	83.9	82.3	7.1	2.5	3.7	0.0021	16	15
3	100L	1LE1001-1AA4-...4	IE 2	2905	9.9	3.3	6.1	0.84	84.6	85.2	84.7	7	2.3	3.3	0.0044	16	21
4	112M	1LE1001-1BA2-...4	IE 2	2950	13	3.7	7.8	0.86	85.8	86.7	86.1	7.4	2.4	3.3	0.0092	16	27
5.5	132S	1LE1001-1CA0-...4	IE 2	2950	18	4.3	10.5	0.87	87.0	88.0	87.4	6.6	1.8	2.9	0.02	16	39
7.5	132S	1LE1001-1CA1-...4	IE 2	2950	24	5.7	14.1	0.87	88.1	88.7	88.6	7.5	2.2	3.1	0.024	16	43
11	160M	1LE1001-1DA2-...4	IE 2	2955	36	8.4	20.5	0.87	89.4	90.0	89.1	7.4	2.1	3.2	0.045	16	67
15	160M	1LE1001-1DA3-...4	IE 2	2955	48	10.6	27	0.88	90.3	90.9	90.3	7.6	2.4	3.4	0.053	16	75
18.5	160L	1LE1001-1DA4-...4	IE 2	2955	60	13	33.5	0.88	90.9	91.2	90.4	7.9	2.9	3.6	0.061	16	84

Electrical data - 1LE10 - IE2 - 4-pole (IE2 Aluminum) 1500 rpm 4-pole, 400 V 50 Hz																	
Rated output kW	Frame size	Article number	IE class	Rated speed rpm	Rated torque Nm	No load current A	Rated current A	Rated power factor	Efficiency at			Starting		Break-down torque Nm	Moment of inertia kgm ²	Torque class	Net weight (IMB3) kg
									100% load %	75% load %	50% load %	current	torque				
0.55	80M	1LE1001-0DB2-...4	-	1440	3.7	0.99	1.37	0.74	78.1	78.9	76.1	5.3	2.2	3.1	0.0017	16	10
0.75	80M	1LE1001-0DB3-...4	IE 2	1440	5	1.21	1.79	0.76	79.6	80.2	78.0	5.6	2.2	3.1	0.0021	16	11
1.1	90S	1LE1001-OEB0-...4	IE 2	1425	7.4	1.7	2.5	0.78	81.4	81.7	79.9	5.6	2.3	2.9	0.0028	16	13
1.5	90L	1LE1001-OEB4-...4	IE 2	1435	10	2.1	3.3	0.79	82.8	83.5	82.0	6.4	2.6	3.4	0.0036	16	16
2.2	100L	1LE1001-1AB4-...4	IE 2	1455	14	2.6	4.65	0.81	84.3	85.1	84.3	6.9	2.1	3.3	0.0086	16	21
3	100L	1LE1001-1AB5-...4	IE 2	1455	20	3.35	6.2	0.82	85.5	86.7	86.0	6.9	2	3.1	0.011	16	25
4	112M	1LE1001-1BB2-...4	IE 2	1460	26	4.3	8.2	0.81	86.6	87.3	86.5	7.1	2.5	3.2	0.014	16	29
5.5	132S	1LE1001-1CB0-...4	IE 2	1465	36	5.7	11.3	0.8	87.7	89.0	87.7	6.9	2.3	2.9	0.027	16	42
7.5	132M	1LE1001-1CB2-...4	IE 2	1465	49	6.5	14.7	0.83	88.7	90.3	88.8	6.9	2.3	2.9	0.034	16	49
11	160M	1LE1001-1DB2-...4	IE 2	1470	71	8.7	21	0.85	89.8	90.9	90.8	6.7	2.1	2.8	0.065	16	71
15	160L	1LE1001-1DB4-...4	IE 2	1475	97	11.3	28	0.85	90.6	91.3	91.0	7.3	2.3	3	0.083	16	83

Electrical data - 1LE10 - IE2 - 6-pole (IE2 Aluminum) 1000 rpm 6-pole, 400 V 50 Hz																	
Rated output kW	Frame size	Article number	IE class	Rated speed rpm	Rated torque Nm	No load current A	Rated current A	Rated power factor	Efficiency at			Starting		Break-down torque Nm	Moment of inertia kgm ²	Torque class	Net weight (IMB3) kg
									100% load %	75% load %	50% load %	current	torque				
0.37	80M	1LE1001-ODC2-...4	-	925	3.85	0.81	1.08	0.69	71.4	71.5	66.5	4	2.1	2.4	0.001716	16	9
0.55	80M	1LE1001-ODC3-...4	-	935	5.6	1.07	1.63	0.66	74.0	74.0	70.5	4.4	2.5	2.9	0.0025	16	12
0.75	90S	1LE1001-OEC0-...4	IE2	925	7.7	1.2	2.05	0.7	75.9	76.0	73.0	4.1	2	2.5	0.003	16	13
1.1	90L	1LE1001-OEC4-...4	IE2	935	11.2	1.93	2.9	0.7	78.1	78.5	75.0	4.4	2.2	2.6	0.004	16	16
1.5	100L	1LE1001-1AC4-...4	IE2	970	15	2.2	3.7	0.73	79.8	80.2	79.0	6.2	2	2.9	0.011	16	25
2.2	112M	1LE1001-1BC2-...4	IE2	965	22	2.9	5.2	0.75	81.8	82.5	81.3	6	2.1	3.1	0.014	16	29
3	132S	1LE1001-1CC0-...4	IE2	970	30	4.2	7	0.74	83.3	84.0	82.8	5.6	1.6	2.6	0.024	13	38
4	132M	1LE1001-1CC2-...4	IE2	970	39	4.5	8.7	0.78	84.6	85.8	85.0	5.6	1.6	2.5	0.029	13	43
5.5	132M	1LE1001-1CC3-...4	IE2	970	54	6.3	12	0.77	86.0	87.4	87.0	6.1	1.9	2.8	0.037	16	52
7.5	160M	1LE1001-1DC2-...4	IE2	975	73	8.25	16.1	0.77	87.2	87.7	86.9	6.3	1.8	2.8	0.075	16	77
11	160L	1LE1001-1DC4-...4	IE2	975	108	10.1	22.5	0.8	88.7	89.5	89.4	6.2	1.7	2.7	0.098	16	93



The nominal torque of the motor is easy to calculate;
 Torque (Nm) =
 Power (kW) x 9550 / Speed (rpm).

SIMOTICS General Purpose (Cast Iron) – IE1

	Cast Iron Series					
Efficiency class	IE1			IE2		
Series	1LE0102			1LE0101		
No. of poles	2	4	6	2	4	6
Cooling	Self-ventilated (IC 411)			Self-ventilated (IC 411)		
Degree of protection	IP55			IP55		
Insulation	Thermal class 155(F)			Thermal class 155(F)		
Utilization	Thermal class 130(B)			Thermal class 130(B)		
Frame size	80 ... 355			80 ... 355		
Rated output at 50 Hz	0.55 ... 315 kW			0.55 ... 315 kW		
Rated torque at 50 Hz	2.6 ... 2414 Nm			2.6 ... 2412 Nm		

Electrical data - 1LE0 - IE1 - 2-pole (IE1 Cast Iron) 3000 rpm 2-pole, 400 V 50 Hz																	
Rated output	Frame size	Article number	IE class	Rated speed	Rated torque	No load current	Rated current	Rated power factor	Efficiency at			Starting		Break-down torque	Moment of inertia	Torque class	Net weight (IMB3)
kW				rpm	Nm	A	A		100% load %	75% load %	50% load %	current	torque	Nm	kgm ²		kg
230 VΔ / 400 VY																	
0.75	80M	1LE0102-0DA22-2..4	IE 1	2800	2.6	0.95	1.76	0.86	72.1	73.0	71.1	5.1	2.3	2.7	0.0008	D	15.0
1.1	80M	1LE0102-0DA32-2..4	IE 1	2830	3.7	1.16	2.50	0.86	75.0	77.3	74.4	6	2.6	3.1	0.001	E	17.5
1.5	90S	1LE0102-0EA02-2..4	IE 1	2885	5	1.82	3.30	0.85	77.2	76.9	73.5	6.9	2.5	3.2	0.0017	F	22
2.2	90L	1LE0102-0EA42-2..4	IE 1	2885	7.3	2.15	4.50	0.87	79.7	80.5	78.1	7.5	2.7	3.4	0.0022	F	26
3	100L	1LE0102-1AA42-2..4	IE 1	2850	10	2.80	6.3	0.85	81.5	82.1	79.9	6.9	3	3.7	0.0033	F	33
4	112M	1LE0102-1BA22-2..4	IE 1	2910	13.1	6.5	8.2	0.85	83.1	83.7	81.5	7.8	2.9	4.2	0.0064	L	39
5.5	132S	1LE0102-1CA02-2..4	IE 1	2915	18	8.0	10.9	0.86	84.7	85.3	83.7	6.9	2	3.1	0.013	K	55
7.5	132S	1LE0102-1CA12-2..4	IE 1	2920	24.5	11.3	14.3	0.88	86.0	87.2	86.2	7.1	2	2.9	0.015	K	60
400 VΔ / 690 VY																	
3	100L	1LE0102-1AA43-4..4	IE 1	2850	10	2.75	6.3	0.85	81.5	82.1	79.9	6.9	3	3.7	0.0033	F	33
4	112M	1LE0102-1BA23-4..4	IE 1	2910	13.1	3.80	8.2	0.85	83.1	83.7	81.5	7.8	2.9	4.2	0.0064	L	39
5.5	132S	1LE0102-1CA03-4..4	IE 1	2915	18	5.0	10.9	0.86	84.7	85.3	83.7	6.9	2	3.1	0.013	K	55
7.5	132S	1LE0102-1CA13-4..4	IE 1	2920	24.5	5.9	14.3	0.88	86.0	87.2	86.2	7.1	2	2.9	0.015	K	60
11	160M	1LE0102-1DA23-4..4	IE 1	2925	35.9	9.3	21.5	0.84	87.6	88.2	87.1	6.3	2	3.1	0.028	J	93
15	160M	1LE0102-1DA33-4..4	IE 1	2930	48.9	12.1	28.5	0.85	88.7	89.3	87.4	7	2.2	3.2	0.034	K	101
18.5	160L	1LE0102-1DA43-4..4	IE 1	2935	60	14.1	35.0	0.86	89.3	89.9	89.1	7.6	2.5	3.4	0.041	K	120
22	180M	1LE0102-1EA23-4..4	IE 1	2925	72	13.3	40.5	0.87	89.9	90.6	90.0	7.6	2.7	3.5	0.072	K	151
30	200L	1LE0102-2AA43-4..4	IE 1	2950	97	18.7	55	0.87	90.7	90.8	89.0	7.5	2.5	3.2	0.12	K	224
37	200L	1LE0102-2AA53-4..4	IE 1	2950	120	19.5	67	0.88	91.2	91.6	90.4	7.4	2.6	3.2	0.15	K	242
45	225M	1LE0102-2BA23-4..4	IE 1	2960	145	24.0	81	0.88	91.7	91.9	90.5	7.6	2.8	3.3	0.23	K	304
55	250M	1LE0102-2CA23-4..4	IE 1	2970	177	32.0	98	0.88	92.1	92.4	90.7	7.7	2.5	3.1	0.4	K	374
75	280S	1LE0102-2DA03-4..4	IE 1	2970	241	42.5	134	0.87	92.7	92.6	91.1	6.7	2.7	3	0.7	J	540
90	280M	1LE0102-2DA23-4..4	IE 1	2975	289	47.5	159	0.88	93.0	93.2	91.3	7.2	2.8	3	0.82	J	560
110	315S	1LE0102-3AA03-4..4	IE 1	2982	353	49.5	189	0.90	93.3	93.1	91.2	7.5	2.2	3.1	1.4	K	735
132	315M	1LE0102-3AA23-4..4	IE 1	2980	423	46.0	220	0.92	93.5	93.1	91.7	7.5	2.3	2.9	1.7	J	850
160	315L	1LE0102-3AA53-4..4	IE 1	2982	513	56	265	0.92	93.8	93.6	92.5	7.6	2.5	2.8	1.9	J	960
185	315L	1LE0102-3AA63-4..4	IE 1	2978	594	50	310	0.92	93.9	93.9	93.1	7.5	2.4	2.8	2.3	J	1070
200	315L	1LE0102-3AA73-4..4	IE 1	2980	641	65	335	0.92	94.0	94.3	93.2	7.9	2.5	2.6	2.3	K	1080
220	355M	1LE0102-3BA23-4..4	IE 1	2985	704	43.0	370	0.90	94.8	95.0	92.8	6.5	2	2.1	2.9	H	1590
250	355M	1LE0102-3BA33-4..4	IE 1	2985	800	54	420	0.90	95.2	95.2	93.0	6.5	2	2.1	3	H	1620
280	355L	1LE0102-3BA53-4..4	IE 1	2985	896	57	470	0.90	95.2	95.2	92.9	6.5	2	2.1	3.5	H	1820
315	355L	1LE0102-3BA63-4..4	IE 1	2985	1008	61	530	0.90	95.4	95.4	93.2	6.5	2	2.1	3.5	H	1830

SIMOTICS General Purpose (Cast Iron) – IE1

Cast Iron Series						
Efficiency class	IE1			IE2		
Series	1LE0102			1LE0101		
No. of poles	2	4	6	2	4	6
Cooling	Self-ventilated (IC 411)			Self-ventilated (IC 411)		
Degree of protection	IP55			IP55		
Insulation	Thermal class 155(F)			Thermal class 155(F)		
Utilization	Thermal class 130(B)			Thermal class 130(B)		
Frame size	80 ... 355			80 ... 355		
Rated output at 50 Hz	0.55 ... 315 kW			0.55 ... 315 kW		
Rated torque at 50 Hz	2.6 ... 2414 Nm			2.6 ... 2412 Nm		

Electrical data - 1LE0 - IE1 - 4-pole (IE1 Cast Iron) 1500 rpm 4-pole, 400 V 50 Hz																	
Rated output	Frame size	Article number	IE class	Rated speed	Rated torque	No load current	Rated current	Rated power factor	Efficiency at			Starting		Break-down torque	Moment of inertia	Torque class	Net weight (IMB3)
kW				rpm	Nm	A	A		100% load %	75% load %	50% load %	current	torque	Nm	kgm ²		kg
230 VΔ / 400 VY																	
0.55	80M	1LE0102-0DB22-2..4	-	1415	3.7	0.76	1.43	0.81	69.4	69.9	66.8	4.5	2	2.6	0.0016	D	17.0
0.75	80M	1LE0102-0DB32-2..4	IE 1	1405	5.1	0.99	1.87	0.81	72.1	73.7	71.8	4.8	2	2.6	0.0019	D	18.5
1.1	90S	1LE0102-0EB02-2..4	IE 1	1420	7.4	1.58	2.65	0.80	75.0	77.3	74.3	5.4	2	2.6	0.0027	E	23
1.5	90L	1LE0102-0EB42-2..4	IE 1	1425	10	2.1	3.50	0.81	77.2	77.3	75.1	5.6	2	2.5	0.0034	E	26
2.2	100L	1LE0102-1AB42-2..4	IE 1	1425	14.8	2.80	4.95	0.81	79.7	80.7	78.7	5.8	2.4	2.9	0.0063	E	30
3	100L	1LE0102-1AB52-2..4	IE 1	1420	20.2	3.15	6.4	0.83	81.5	83.1	81.5	6.5	2.8	3.1	0.0081	E	33
4	112M	1LE0102-1BB22-2..4	IE 1	1445	26.4	9.2	8.8	0.79	83.1	83.3	81.5	7.4	2.8	3.3	0.011	M	44
5.5	132S	1LE0102-1CB02-2..4	IE 1	1450	36.2	9.7	11.4	0.82	84.7	85.5	84.3	6.5	2	3.1	0.019	K	59
7.5	132M	1LE0102-1CB22-2..4	IE 1	1435	50	12.0	15.4	0.82	86.0	87.2	87.2	6.4	2.3	3.1	0.025	K	70
400 VΔ / 690 VY																	
2.2	100L	1LE0102-1AB43-4..4	IE 1	1425	14.8	2.70	4.90	0.81	79.7	80.7	78.7	5.8	2.4	2.9	0.0063	E	30
3	100L	1LE0102-1AB53-4..4	IE 1	1420	20.2	3.15	6.4	0.83	81.5	83.1	81.5	6.5	2.8	3.1	0.0081	E	33
4	112M	1LE0102-1BB23-4..4	IE 1	1445	26.4	5.1	8.8	0.79	83.1	83.3	81.5	7.4	2.8	3.3	0.011	M	44
5.5	132S	1LE0102-1CB03-4..4	IE 1	1450	36.2	5.5	11.4	0.82	84.7	85.5	84.3	6.5	2	3.1	0.019	K	59
7.5	132M	1LE0102-1CB23-4..4	IE 1	1435	50	6.5	15.4	0.82	86.0	87.2	87.2	6.4	2.3	3.1	0.025	K	70
11	160M	1LE0102-1DB23-4..4	IE 1	1455	72	9.3	21.5	0.84	87.6	88.5	87.8	6.9	2.2	3.3	0.045	K	99
15	160L	1LE0102-1DB43-4..4	IE 1	1460	98	13.3	29.0	0.84	88.7	89.4	88.6	7.8	2.7	3.8	0.06	L	125
18.5	180M	1LE0102-1EB23-4..4	IE 1	1470	120	13.8	35.0	0.85	89.3	90.3	89.9	7.8	2.7	3.5	0.13	L	163
22	180L	1LE0102-1EB43-4..4	IE 1	1465	143	15.9	41.5	0.85	89.9	90.9	89.9	7.8	2.4	3.2	0.14	L	179
30	200L	1LE0102-2AB43-4..4	IE 1	1470	195	23.0	56	0.85	90.7	91.6	90.5	7.4	2.4	3.1	0.22	K	235
37	225S	1LE0102-2BB03-4..4	IE 1	1470	240	23.5	68	0.86	91.2	91.8	91.0	7.3	2.3	2.8	0.44	K	295
45	225M	1LE0102-2BB23-4..4	IE 1	1475	292	28.5	82	0.87	91.7	92.4	92.0	7.8	2.9	3.3	0.5	K	322
55	250M	1LE0102-2CB23-4..4	IE 1	1478	356	32.5	101	0.86	92.1	92.8	92.0	7.6	3	2.8	0.8	K	410
75	280S	1LE0102-2DB03-4..4	IE 1	1480	484	42.0	133	0.88	92.7	93.3	92.2	7.2	2.6	2.8	1.3	J	540
90	280M	1LE0102-2DB23-4..4	IE 1	1485	579	58	159	0.88	93.0	93.5	92.2	7.8	2.7	2.8	1.4	K	600
110	315S	1LE0102-3AB03-4..4	IE 1	1490	706	70	200	0.85	93.3	93.4	92.5	8.6	2.8	3.1	2.2	L	745
132	315M	1LE0102-3AB23-4..4	IE 1	1488	848	60	235	0.87	93.5	93.8	93.4	7.3	2.5	2.7	2.5	J	875
160	315L	1LE0102-3AB53-4..4	IE 1	1488	1030	83	285	0.87	93.8	94.0	93.6	7.4	3	2.9	3	K	950
185	315L	1LE0102-3AB63-4..4	IE 1	1490	1185	92	325	0.88	93.9	94.1	93.6	7.6	3	2.9	3.6	K	1060
200	315L	1LE0102-3AB73-4..4	IE 1	1488	1285	84	345	0.88	94.0	94.3	94.1	7.4	3	3	3.7	J	1070
220	355M	1LE0102-3BB23-4..4	IE 1	1490	1410	59	380	0.87	95.0	95.1	93.1	6.5	2.1	2.2	6.6	H	1630
250	355M	1LE0102-3BB33-4..4	IE 1	1490	1602	59	435	0.87	95.2	95.2	93.6	6.5	2.1	2.2	6.9	H	1650
280	355L	1LE0102-3BB53-4..4	IE 1	1490	1795	71	485	0.87	95.2	95.2	93.4	6.5	2.1	2.2	7.7	H	1820
315	355L	1LE0102-3BB63-4..4	IE 1	1490	2019	72	550	0.87	95.2	95.3	93.6	6.5	2.1	2.2	8.5	H	1890



The nominal torque of the motor is easy to calculate;
 Torque (Nm) =
 Power (kW) x 9550 / Speed (rpm).

SIMOTICS General Purpose (Cast Iron) – IE1

	Cast Iron Series					
Efficiency class	IE1			IE2		
Series	1LE0102			1LE0101		
No. of poles	2	4	6	2	4	6
Cooling	Self-ventilated (IC 411)			Self-ventilated (IC 411)		
Degree of protection	IP55			IP55		
Insulation	Thermal class 155(F)			Thermal class 155(F)		
Utilization	Thermal class 130(B)			Thermal class 130(B)		
Frame size	80 ... 355			80 ... 355		
Rated output at 50 Hz	0.55 ... 315 kW			0.55 ... 315 kW		
Rated torque at 50 Hz	2.6 ... 2414 Nm			2.6 ... 2412 Nm		

Electrical data - 1LE0 - IE1 - 6-pole (IE1 Cast Iron) 1000 rpm 6-pole, 400 V 50 Hz																	
Rated output kW	Frame size	Article number	IE class	Rated speed rpm	Rated torque Nm	No load current A	Rated current A	Rated power factor	Efficiency at load %			Starting current torque		Break-down torque Nm	Moment of inertia kgm ²	Torque class	Net weight (IMB3) kg
									100%	75%	50%	cur-ent	torque				
230 VΔ / 400 VY																	
0.55	80M	1LE0102-0DC32-2..4	-	910	5.8	1.04	1.60	0.74	67.5	68.7	65.6	3.8	2.1	2.4	0.0024	C	18.0
0.75	90S	1LE0102-0EOC02-2..4	IE 1	925	7.7	1.27	2.10	0.74	70.0	71.5	68.9	3.9	2	2.5	0.0028	C	25
1.1	90L	1LE0102-0EC42-2..4	IE 1	935	11.3	1.89	3.00	0.73	72.9	74.0	71.8	4.4	2.2	2.7	0.0038	D	26
1.5	100L	1LE0102-1AC42-2..4	IE 1	940	15.4	2.30	3.80	0.76	75.2	77.2	74.7	4.6	2.1	2.6	0.0074	D	32
2.2	112M	1LE0102-1BC22-2..4	IE 1	940	22.3	3.00	5.5	0.75	77.7	79.2	78.1	5.2	2.4	3	0.01	E	42
3	132S	1LE0102-1CC02-2..4	IE 1	955	30	4.15	7.5	0.73	79.7	80.9	79.3	5.2	2	2.8	0.018	E	55
4	132M	1LE0102-1CC22-2..4	IE 1	955	40	10.8	9.7	0.73	81.4	82.2	79.4	5.6	2.1	2.9	0.023	K	65
5.5	132M	1LE0102-1CC32-2..4	IE 1	955	55	12.1	12.9	0.74	83.1	84.2	83.0	6	2.3	3.2	0.029	K	73
400 VΔ / 690 VY																	
1.5	100L	1LE0102-1AC43-4..4	IE 1	940	15.4	2.30	3.80	0.76	75.2	77.2	74.7	4.6	2.1	2.6	0.0074	D	32
2.2	112M	1LE0102-1BC23-4..4	IE 1	940	22.3	3.05	5.4	0.75	77.7	79.2	78.1	5.2	2.4	3	0.01	E	42
3	132S	1LE0102-1CC03-4..4	IE 1	955	30	4.15	7.4	0.73	79.7	80.9	79.3	5.2	2	2.8	0.018	E	55
4	132M	1LE0102-1CC23-4..4	IE 1	955	40	6.2	9.7	0.73	81.4	82.2	79.4	5.6	2.1	2.9	0.023	K	65
5.5	132M	1LE0102-1CC33-4..4	IE 1	955	55	7.3	12.9	0.74	83.1	84.2	83.0	6	2.3	3.2	0.029	K	73
7.5	160M	1LE0102-1DC23-4..4	IE 1	965	74	9.2	16.8	0.76	84.7	85.4	84.5	5.8	2	2.9	0.052	K	101
11	160L	1LE0102-1DC43-4..4	IE 1	965	109	13.3	24.0	0.76	86.4	87.0	86.0	6.6	2.2	3.1	0.072	K	128
15	180L	1LE0102-1EC43-4..4	IE 1	970	148	14.2	32.0	0.78	87.7	88.7	88.4	6.5	2.3	3	0.18	K	169
18.5	200L	1LE0102-2AC43-4..4	IE 1	975	182.1	13.1	36.5	0.82	88.6	90.0	90.1	5.8	2.2	2.8	0.26	J	218
22	200L	1LE0102-2AC53-4..4	IE 1	975	215	15.0	43.0	0.82	89.2	90.5	90.5	6.5	2.3	2.8	0.31	J	237
30	225M	1LE0102-2BC23-4..4	IE 1	978	293	23.0	58	0.83	90.2	91.4	90.5	6.7	2.4	2.8	0.6	K	290
37	250M	1LE0102-2CC23-4..4	IE 1	982	360	26.0	71	0.83	90.8	91.5	91.2	7.5	3	2.8	0.89	K	389
45	280S	1LE0102-2DC03-4..4	IE 1	985	437	28.0	84	0.85	91.4	92.4	92.3	7.1	2.5	2.8	1.1	K	500
55	280M	1LE0102-2DC23-4..4	IE 1	988	532	35.0	102	0.85	91.9	92.6	92.4	7.5	2.4	2.7	1.4	K	525
75	315S	1LE0102-3AC03-4..4	IE 1	988	725	55	141	0.83	92.6	93.0	92.4	7.5	2.4	3	2.3	K	675
90	315M	1LE0102-3AC23-4..4	IE 1	986	872	54	166	0.84	92.9	93.4	93.2	7	2.3	2.8	2.8	K	830
110	315L	1LE0102-3AC53-4..4	IE 1	986	1066	57	200	0.86	93.3	93.9	93.8	6.5	2.2	2.7	3.4	J	915
132	315L	1LE0102-3AC63-4..4	IE 1	988	1278	78	235	0.86	93.5	94.2	93.6	7.8	2.2	2.4	3.9	K	1010
160	355M	1LE0102-3BC23-4..4	IE 1	989	1545	53	275	0.88	94.5	94.6	92.4	6.5	2	2.1	7.7	H	1640
185	355M	1LE0102-3BC33-4..4	IE 1	989	1786	55	320	0.88	94.5	94.6	92.6	6.5	2	2.1	8.4	H	1680
200	355M	1LE0102-3BC43-4..4	IE 1	989	1931	60	345	0.88	94.7	94.7	93.4	6.5	2	2.1	9.1	H	1720
220	355L	1LE0102-3BC53-4..4	IE 1	989	2124	68	380	0.88	94.7	94.7	92.6	6.5	2	2.1	10.1	H	1840
250	355L	1LE0102-3BC63-4..4	IE 1	989	2414	80	430	0.88	94.7	94.7	93.4	6.5	2	2.1	11.4	H	1920

SIMOTICS General Purpose (Cast Iron) – IE2

Cast Iron Series						
Efficiency class	IE1			IE2		
Series	1LE0102			1LE0101		
No. of poles	2	4	6	2	4	6
Cooling	Self-ventilated (IC 411)			Self-ventilated (IC 411)		
Degree of protection	IP55			IP55		
Insulation	Thermal class 155(F)			Thermal class 155(F)		
Utilization	Thermal class 130(B)			Thermal class 130(B)		
Frame size	80 ... 355			80 ... 355		
Rated output at 50 Hz	0.55 ... 315 kW			0.55 ... 315 kW		
Rated torque at 50 Hz	2.6 ... 2414 Nm			2.6 ... 2412 Nm		

Electrical data - 1LE0 - IE2 - 2-pole (IE2 Cast Iron) 3000 rpm 2-pole, 400 V 50 Hz																	
Rated output kW	Frame size	Article number	IE class	Rated speed rpm	Rated torque Nm	No load current A	Rated current A	Rated power factor	Efficiency at			Starting		Break-down torque Nm	Moment of inertia kgm ²	Torque class	Net weight (IMB3) kg
									100% load %	75% load %	50% load %	current	torque				
230 VΔ / 400 VY																	
0.75	80M	1LE0101-0DA22-2..4	IE 2	2795	2.6	0.70	1.67	0.84	77.4	78.5	78.5	5.6	2.4	2.4	0.00080	D	15.5
1.1	80M	1LE0101-0DA32-2..4	IE 2	2835	3.7	1.13	2.40	0.84	79.6	80.6	77.4	6.0	2.8	3.2	0.0012	E	17.5
1.5	90S	1LE0101-0EA02-2..4	IE 2	2890	5.0	1.52	3.20	0.84	81.3	81.7	78.0	6.5	2.4	3.1	0.0021	E	23
2.2	90L	1LE0101-0EA42-2..4	IE 2	2890	7.3	2.30	4.55	0.85	83.2	83.7	80.8	7.2	2.6	3.5	0.0026	F	26
3	100L	1LE0101-1AA42-2..4	IE 2	2885	9.9	2.85	6.1	0.84	84.6	85.1	84.1	7.5	4.0	4.5	0.0036	F	34
4	112M	1LE0101-1BA22-2..4	IE 2	2930	13.0	5.9	7.8	0.86	85.8	86.6	84.7	7.5	2.2	2.9	0.0064	L	40
5.5	132S	1LE0101-1CA02-2..B4	IE 2	2930	17.9	6.9	10.5	0.87	87.0	87.6	86.9	7.5	2.2	2.9	0.014	K	56
7.5	132S	1LE0101-1CA12-2..B4	IE 2	2930	24.4	8.4	13.8	0.89	88.1	88.8	88.5	7.5	2.3	2.9	0.017	K	62
400 VΔ / 690 VY																	
3	100L	1LE0101-1AA43-4..4	IE 2	2885	9.9	2.85	6.1	0.84	84.6	85.1	84.1	7.5	4	4.5	0.0036	F	34
4	112M	1LE0101-1BA23-4..4	IE 2	2930	13.0	3.70	7.8	0.86	85.8	86.6	84.7	7.5	2.2	2.9	0.0064	L	40
5.5	132S	1LE0101-1CA03-4..B4	IE 2	2930	17.9	4.30	10.5	0.87	87.0	87.6	86.9	7.5	2.2	2.9	0.014	K	56
7.5	132S	1LE0101-1CA13-4..B4	IE 2	2930	24.4	4.65	13.8	0.89	88.1	88.8	88.5	7.5	2.3	2.9	0.017	K	62
11	160M	1LE0101-1DA23-4..B4	IE 2	2935	35.8	8.1	20.5	0.86	89.4	90.1	89.3	7.5	2.2	2.9	0.031	K	96
15	160M	1LE0101-1DA33-4..B4	IE 2	2935	48.8	10.4	28	0.86	90.3	91.0	90.5	7.5	2.4	3.2	0.038	K	106
18.5	160L	1LE0101-1DA43-4..B4	IE 2	2935	60.2	10.3	33	0.89	90.9	91.7	91.5	7.5	2.4	3.2	0.046	K	125
22	180M	1LE0101-1EA23-4..B4	IE 2	2935	71.6	13.5	40	0.87	91.3	91.8	91.1	7.6	2.5	3.2	0.072	K	152
30	200L	1LE0101-2AA43-4..B4	IE 2	2955	97.0	18.0	55	0.86	92.0	92.3	91.5	7.5	2.5	3.2	0.13	K	229
37	200L	1LE0101-2AA53-4..B4	IE 2	2955	120	19.0	66	0.88	92.5	92.8	92.3	7.5	2.5	3.2	0.15	K	245
45	225M	1LE0101-2BA23-4..B4	IE 2	2965	145	23.0	80	0.88	92.9	93.1	92.5	7.9	2.5	3.1	0.24	K	307
55	250M	1LE0101-2CA23-4..B4	IE 2	2970	177	28.5	97	0.88	93.2	93.2	91.8	7.5	2.5	3	0.42	K	378
75	280S	1LE0101-2DA03-4..B4	IE 2	2975	241	41.0	133	0.87	93.8	93.8	92.7	7.5	2.8	3	0.75	K	550
90	280M	1LE0101-2DA23-4..B4	IE 2	2978	289	49.5	159	0.87	94.1	94.1	92.9	7.5	3	3.1	0.88	K	570
110	315S	1LE0101-3AA03-4..B4	IE 2	2982	352	47.5	187	0.90	94.3	94.3	93.3	7.5	2.2	2.6	1.4	J	740
132	315M	1LE0101-3AA23-4..B4	IE 2	2982	423	46.5	220	0.91	94.6	94.6	93.9	7.5	2.3	2.9	1.7	J	855
160	315L	1LE0101-3AA53-4..B4	IE 2	2982	512	52	265	0.92	94.8	95.1	94.1	7.5	2.5	2.8	1.9	J	970
185	315L	1LE0101-3AA63-4..B4	IE 2	2982	592	64	305	0.92	95.0	95.3	94.2	7.5	2.5	2.8	2.3	J	1080
200	315L	1LE0101-3AA73-4..B4	IE 2	2982	641	64	330	0.92	95.0	95.3	94.4	7.5	2.5	2.8	2.3	J	1090
220	355M	1LE0101-3BA23-4..B4	IE 2	2980	705	50	370	0.90	95.0	95.0	92.8	7.1	2	2.2	2.9	J	1600
250	355M	1LE0101-3BA33-4..B4	IE 2	2980	801	46	420	0.90	95.0	95.0	93.0	7.1	2	2.2	3	J	1650
280	355L	1LE0101-3BA53-4..B4	IE 2	2980	897	56	475	0.90	95.0	95.1	93.0	7.1	2	2.2	3.5	J	1830
315	355L	1LE0101-3BA63-4..B4	IE 2	2980	1009	57	530	0.90	95.0	95.1	93.1	7.1	2	2.3	3.5	J	1840



The nominal torque of the motor is easy to calculate;
 Torque (Nm) =
 Power (kW) x 9550 / Speed (rpm).

SIMOTICS General Purpose (Cast Iron) – IE2

	Cast Iron Series					
Efficiency class	IE1			IE2		
Series	1LE0102			1LE0101		
No. of poles	2	4	6	2	4	6
Cooling	Self-ventilated (IC 411)			Self-ventilated (IC 411)		
Degree of protection	IP55			IP55		
Insulation	Thermal class 155(F)			Thermal class 155(F)		
Utilization	Thermal class 130(B)			Thermal class 130(B)		
Frame size	80 ... 355			80 ... 355		
Rated output at 50 Hz	0.55 ... 315 kW			0.55 ... 315 kW		
Rated torque at 50 Hz	2.6 ... 2414 Nm			2.6 ... 2412 Nm		

Electrical data - 1LE0 - IE2 - 4-pole (IE2 Cast Iron) 1500 rpm 4-pole, 400 V 50 Hz																	
Rated output	Frame size	Article number	IE class	Rated speed	Rated torque	No load current	Rated current	Rated power factor	Efficiency at			Starting		Break-down torque	Moment of inertia	Torque class	Net weight (IMB3)
kW				rpm	Nm	A	A		100% load %	75% load %	50% load %	current	torque	Nm	kgm ²		kg
230 VΔ / 400 VY																	
0.55	80M	1LE0101-0DB22-2..4	-	1425	3.7	0.80	1.34	0.80	74.0	74.7	70.1	6.0	2.0	2.7	0.0021	F	17.5
0.75	80M	1LE0101-0DB32-2..4	IE 2	1440	5.0	1.00	1.82	0.75	79.6	79.6	76.8	6.5	2.8	3.5	0.0027	F	19
1.1	90S	1LE0101-0EB02-2..4	IE 2	1440	7.3	1.60	2.65	0.75	81.4	81.4	77.6	7.0	2.8	3.5	0.0041	G	24
1.5	90L	1LE0101-0EB42-2..4	IE 2	1440	9.9	2.05	3.45	0.76	82.8	82.8	80.2	7.0	3.0	3.8	0.0047	G	27
2.2	100L	1LE0101-1AB42-2..4	IE 2	1435	14.6	2.65	4.8	0.79	84.3	85.0	83.1	7.0	3.0	3.2	0.0081	F	33
3	100L	1LE0101-1AB52-2..4	IE 2	1435	20.0	3.50	6.4	0.79	85.5	86.3	84.2	7.0	3.0	3.2	0.01	F	37
4	112M	1LE0101-1BB22-2..4	IE 2	1445	26.4	7.6	8.4	0.79	86.6	87.1	85.8	7.1	2.7	3.1	0.011	L	45
5.5	132S	1LE0101-1CB02-2..B4	IE 2	1460	36.0	10.6	11.5	0.79	87.7	88.2	86.9	7.5	2.5	3.1	0.021	L	61
7.5	132M	1LE0101-1CB22-2..B4	IE 2	1460	49.1	11.5	14.9	0.82	88.7	89.4	88.8	7.7	2.7	3.2	0.029	L	73
400 VΔ / 690 VY																	
2.2	100L	1LE0101-1AB43-4..4	IE 2	1435	14.6	2.6	4.75	0.79	84.3	85.0	83.1	7.0	3.0	3.2	0.0081	F	33
3	100L	1LE0101-1AB53-4..4	IE 2	1435	20.0	3.55	6.4	0.79	85.5	86.3	84.2	7.0	3.0	3.2	0.010	F	37
4	112M	1LE0101-1BB23-4..4	IE 2	1445	26.4	4.45	8.455	0.79	86.6	87.1	85.8	7.1	2.7	3.1	0.011	L	45
5.5	132S	1LE0101-1CB03-4..B4	IE 2	1460	36.0	6.1	11.495	0.79	87.7	88.2	86.9	7.5	2.5	3.1	0.021	L	61
7.5	132M	1LE0101-1CB23-4..B4	IE 2	1460	49.1	6.7	14.915	0.82	88.7	89.4	88.8	7.7	2.7	3.2	0.029	L	73
11	160M	1LE0101-1DB23-4..B4	IE 2	1465	71.7	6.7	21	0.84	89.8	90.4	90.1	7.5	2.5	3.1	0.051	K	103
15	160L	1LE0101-1DB43-4..B4	IE 2	1465	97.8	11.8	28.025	0.85	90.6	91.3	90.6	7.8	2.7	3.2	0.066	K	130
18.5	180M	1LE0101-1EB23-4..B4	IE 2	1465	121	12.3	34.5	0.85	91.2	91.8	91.8	7.3	2.5	3.2	0.13	K	165
22	180L	1LE0101-1EB43-4..B4	IE 2	1465	143	15.4	41	0.85	91.6	92.3	92.7	7.3	2.4	3.2	0.14	K	180
30	200L	1LE0101-2AB43-4..B4	IE 2	1470	195	19.0	55	0.85	92.3	92.9	92.9	7.3	2.7	3.2	0.22	K	238
37	225S	1LE0101-2BB03-4..B4	IE 2	1475	240	23.0	67	0.86	92.7	93.2	92.9	7.3	2.7	3.2	0.45	K	298
45	225M	1LE0101-2BB23-4..B4	IE 2	1475	291	26.0	80	0.87	93.1	93.5	93.9	7.3	2.7	3.2	0.51	K	322
55	250M	1LE0101-2CB23-4..B4	IE 2	1480	355	32.0	99	0.86	93.5	93.9	93.3	7.5	3.1	3.5	0.8	K	410
75	280S	1LE0101-2DB03-4..B4	IE 2	1485	482	45.0	132	0.87	94.0	94.3	93.9	7.5	2.7	3.1	1.4	K	555
90	280M	1LE0101-2DB23-4..B4	IE 2	1485	579	57	159	0.87	94.2	94.3	94.2	7.5	2.7	3.1	1.5	K	610
110	315S	1LE0101-3AB03-4..B4	IE 2	1488	706	67	195	0.86	94.5	94.5	93.9	7.3	2.8	2.9	2.2	K	750
132	315M	1LE0101-3AB23-4..B4	IE 2	1486	848	56	230	0.88	94.7	94.7	95.0	7.3	2.5	2.7	2.5	J	875
160	315L	1LE0101-3AB53-4..B4	IE 2	1488	1027	77	275	0.88	94.9	94.9	95.1	7.4	3.0	2.9	3.0	J	960
185	315L	1LE0101-3AB63-4..B4	IE 2	1488	1187	86	320	0.88	95.1	95.1	95.0	7.4	3.0	3.0	3.6	J	1070
200	315L	1LE0101-3AB73-4..B4	IE 2	1488	1284	86	345	0.88	95.1	95.1	95.1	7.4	3.0	3.0	3.7	J	1080
220	355M	1LE0101-3BB23-4..B4	IE 2	1490	1410	69	370	0.90	95.1	95.2	93.3	6.9	2.0	2.2	6.6	J	1640
250	355M	1LE0101-3BB33-4..B4	IE 2	1490	1602	61	420	0.90	95.1	95.2	93.8	6.9	2.0	2.2	6.9	J	1680
280	355L	1LE0101-3BB53-4..B4	IE 2	1490	1795	66	470	0.90	95.1	95.2	93.8	6.9	2.0	2.2	7.7	J	1830
315	355L	1LE0101-3BB63-4..B4	IE 2	1490	2019	75	530	0.90	95.1	95.2	93.8	6.9	2.0	2.2	8.5	J	1900

SIMOTICS General Purpose (Cast Iron) – IE2

Cast Iron Series						
Efficiency class	IE1			IE2		
Series	1LE0102			1LE0101		
No. of poles	2	4	6	2	4	6
Cooling	Self-ventilated (IC 411)			Self-ventilated (IC 411)		
Degree of protection	IP55			IP55		
Insulation	Thermal class 155(F)			Thermal class 155(F)		
Utilization	Thermal class 130(B)			Thermal class 130(B)		
Frame size	80 ... 355			80 ... 355		
Rated output at 50 Hz	0.55 ... 315 kW			0.55 ... 315 kW		
Rated torque at 50 Hz	2.6 ... 2414 Nm			2.6 ... 2412 Nm		

Electrical data - 1LE0 - IE2 - 6-pole (IE2 Cast Iron) 1000 rpm 6-pole, 400 V 50 Hz																	
Rated output kW	Frame size	Article number	IE class	Rated speed rpm	Rated torque Nm	No load current A	Rated current A	Rated power factor	Efficiency at			Starting		Break-down torque Nm	Moment of inertia kgm ²	Torque class	Net weight (IMB3) kg
									100% load %	75% load %	50% load %	current	torque				
230 VΔ / 400 VY																	
0.55	80M	1LE0101-0DC32-2..4	-	895	5.9	1.08	1.48	0.76	71.0	72.0	68.5	3.8	2.1	2.4	0.0028	C	18.5
0.75	90S	1LE0101-0EOC02-2..4	IE 2	935	7.7	1.27	2.00	0.71	75.9	76.5	72.7	3.9	2.0	2.5	0.0038	C	26
1.1	90L	1LE0101-0EC42-2..4	IE 2	945	11.1	2.00	2.85	0.71	78.1	78.1	75.7	4.4	2.2	2.7	0.0046	D	27
1.5	100L	1LE0101-1AC42-2..4	IE 2	945	15.2	2.45	3.70	0.74	79.8	80.1	78.2	4.6	2.1	2.6	0.0086	D	34
2.2	112M	1LE0101-1BC22-2..4	IE 2	950	22.1	2.90	5.4	0.73	81.8	82.5	81.0	5.2	2.4	3.0	0.012	E	44
3	132S	1LE0101-1CC02-2..4	IE 2	960	29.8	3.70	7.2	0.73	83.3	84.3	83.4	5.2	2.0	2.8	0.019	E	56
4	132M	1LE0101-1CC22-2..4	IE 2	960	39.8	8.7	9.4	0.73	84.6	85.4	84.5	5.6	2.1	2.9	0.024	K	66
5.5	132M	1LE0101-1CC32-2..B4	IE 2	960	54.7	12.6	12.3	0.75	86.0	86.6	85.7	6.0	2.3	3.2	0.031	K	75
400 VΔ / 690 VY																	
1.5	100L	1LE0101-1AC43-4..4	IE 2	945	15.2	2.40	3.65	0.74	79.8	80.1	78.2	4.6	2.1	2.6	0.0086	D	34
2.2	112M	1LE0101-1BC23-4..4	IE 2	950	22.1	2.90	5.3	0.73	81.8	82.5	81.0	5.2	2.4	3.0	0.012	E	44
3	132S	1LE0101-1CC03-4..4	IE 2	960	29.8	3.70	7.1	0.73	83.3	84.3	83.4	5.2	2.0	2.8	0.019	D	56
4	132M	1LE0101-1CC23-4..4	IE 2	960	39.8	5.0	9.3	0.73	84.6	85.4	84.5	5.6	2.1	2.9	0.024	K	66
5.5	132M	1LE0101-1CC33-4..B4	IE 2	960	54.7	6.8	12.4	0.75	86.0	86.6	85.7	6.0	2.3	3.2	0.031	K	75
7.5	160M	1LE0101-1DC23-4..B4	IE 2	965	74.2	7.9	16.2	0.77	87.2	87.9	87.2	5.8	2.0	2.9	0.056	J	104
11	160L	1LE0101-1DC43-4..B4	IE 2	965	109	10.7	23.0	0.78	88.7	89.4	89.5	6.6	2.2	3.1	0.077	K	132
15	180L	1LE0101-1EC43-4..B4	IE 2	975	147	14.8	31.0	0.78	89.7	90.4	89.9	6.5	2.3	3.0	0.18	K	170
18.5	200L	1LE0101-2AC43-4..B4	IE 2	975	181	13.8	36.5	0.81	90.4	91.0	91.8	5.8	2.2	2.8	0.27	J	220
22	200L	1LE0101-2AC53-4..B4	IE 2	975	215	16.4	43.0	0.82	90.9	91.4	91.9	6.5	2.3	2.8	0.32	J	240
30	225M	1LE0101-2BC23-4..B4	IE 2	980	292	19.5	57	0.83	91.7	92.3	92.7	6.7	2.4	2.8	0.62	J	294
37	250M	1LE0101-2CC23-4..B4	IE 2	982	360	23.0	69	0.83	92.2	92.8	92.3	7.5	3.0	2.8	0.91	K	394
45	280S	1LE0101-2DC03-4..B4	IE 2	985	436	28.0	83	0.85	92.7	93.3	93.5	7.1	2.5	2.8	1.2	K	510
55	280M	1LE0101-2DC23-4..B4	IE 2	986	533	34.5	101	0.85	93.1	93.7	93.6	7.5	2.4	2.7	1.5	K	535
75	315S	1LE0101-3AC03-4..B4	IE 2	986	726	53	136	0.85	93.7	94.3	93.8	7.5	2.4	3.0	2.3	K	680
90	315M	1LE0101-3AC23-4..B4	IE 2	986	872	51	163	0.85	94.0	94.5	94.4	7.0	2.3	2.8	2.8	J	835
110	315L	1LE0101-3AC53-4..B4	IE 2	988	1063	57	195	0.86	94.3	94.7	94.6	6.5	2.2	2.7	3.9	J	975
132	315L	1LE0101-3AC63-4..B4	IE 2	988	1276	69	230	0.86	94.6	95.0	94.9	7.8	2.2	2.4	4.3	K	1030
160	355M	1LE0101-3BC23-4..B4	IE 2	990	1543	50	280	0.87	94.8	95.1	93.5	6.5	2.0	2.1	7.7	J	1650
185	355M	1LE0101-3BC33-4..B4	IE 2	990	1785	57	325	0.87	95.0	95.3	93.5	6.5	2.0	2.1	8.4	J	1690
200	355M	1LE0101-3BC43-4..B4	IE 2	990	1929	56	350	0.87	95.0	95.3	93.6	6.5	2.0	2.1	9.1	J	1730
220	355L	1LE0101-3BC53-4..B4	IE 2	990	2122	64	385	0.87	95.0	95.3	93.5	6.5	2.0	2.1	10.1	J	1850
250	355L	1LE0101-3BC63-4..B4	IE 2	990	2412	73	435	0.87	95.0	95.3	93.5	6.5	2.0	2.1	11.4	J	1930



The nominal torque of the motor is easy to calculate;
 Torque (Nm) =
 Power (kW) x 9550 / Speed (rpm).

SIMOTICS General Purpose (Cast Iron) – IE1

	Cast Iron Series					
Efficiency class	IE1			IE2		
Series	1LE0102			1LE0101		
No. of poles	2	4	6	2	4	6
Cooling	Self-ventilated (IC 411)			Self-ventilated (IC 411)		
Degree of protection	IP55			IP55		
Insulation	Thermal class 155(F)			Thermal class 155(F)		
Utilization	Thermal class 130(B)			Thermal class 130(B)		
Frame size	80 ... 355			80 ... 355		
Rated output at 50 Hz	0.55 ... 315 kW			0.55 ... 315 kW		
Rated torque at 50 Hz	2.6 ... 2414 Nm			2.6 ... 2412 Nm		

Electrical data - 1LE0 - IE1 - 2-pole (IE1 Cast Iron) 3000 rpm 2-pole, 525 VA 50 Hz																	
Rated output kW	Frame size	Article number	IE class	Rated speed rpm	Rated torque Nm	No load current A	Rated current A	Rated power factor	Efficiency at			Starting current	Starting torque	Break-down torque Nm	Moment of inertia kgm ²	Torque class	Net weight (IMB3) kg
									100% load %	75% load %	50% load %						
0.75	80M	1LE0102-ODA24-1..4	IE 1	2800	2.6	0.72	1.33	0.86	72.1	73.0	71.1	5.1	2.3	2.7	0.0008	D	15.0
1.1	80M	1LE0102-ODA34-1..4	IE 1	2830	3.7	0.88	1.88	0.86	75.0	77.3	74.4	6.0	2.6	3.1	0.001	E	17.5
1.5	90S	1LE0102-OEA04-1..4	IE 1	2885	5	1.39	2.50	0.85	77.2	76.9	73.5	6.9	2.5	3.2	0.0017	F	22
2.2	90L	1LE0102-OEA44-1..4	IE 1	2885	7.3	1.64	3.50	0.87	79.7	80.5	78.1	7.5	2.7	3.4	0.0022	F	26
3	100L	1LE0102-1AA44-1..4	IE 1	2850	10	2.10	4.80	0.85	81.5	82.1	79.9	6.9	3	3.7	0.0033	F	33
4	112M	1LE0102-1BA24-1..4	IE 1	2910	13.1	2.90	6.2	0.85	83.1	83.7	81.5	7.8	2.9	4.2	0.0064	L	39
5.5	132S	1LE0102-1CA04-1..4	IE 1	2915	18	3.85	8.3	0.86	84.7	85.3	83.7	6.9	2	3.1	0.013	K	55
7.5	132S	1LE0102-1CA14-1..4	IE 1	2920	24.5	4.50	10.9	0.88	86.0	87.2	86.2	7.1	2	2.9	0.015	K	60
11	160M	1LE0102-1DA24-1..4	IE 1	2925	35.9	7.1	16.3	0.84	87.6	88.2	87.1	6.3	2	3.1	0.028	J	93
15	160M	1LE0102-1DA34-1..4	IE 1	2930	48.9	9.2	21.5	0.85	88.7	89.3	87.4	7	2.2	3.2	0.034	K	101
18.5	160L	1LE0102-1DA44-1..4	IE 1	2935	60	10.7	26.5	0.86	89.3	89.9	89.1	7.6	2.5	3.4	0.041	K	120
22	180M	1LE0102-1EA24-1..4	IE 1	2925	72	10.1	31.0	0.87	89.9	90.6	90.0	7.6	2.7	3.5	0.072	K	151
30	200L	1LE0102-2AA44-1..4	IE 1	2950	97	14.3	42.0	0.87	90.7	90.8	89.0	7.5	2.5	3.2	0.12	K	224
37	200L	1LE0102-2AA54-1..4	IE 1	2950	120	14.8	51	0.88	91.2	91.6	90.4	7.4	2.6	3.2	0.15	K	242
45	225M	1LE0102-2BA24-1..4	IE 1	2960	145	18.5	62	0.88	91.7	91.9	90.5	7.6	2.8	3.3	0.23	K	304
55	250M	1LE0102-2CA24-1..4	IE 1	2970	177	24.5	75	0.88	92.1	92.4	90.7	7.7	2.5	3.1	0.4	K	374
75	280S	1LE0102-2DA04-1..4	IE 1	2970	241	32.0	102	0.87	92.7	92.6	91.1	6.7	2.7	3	0.7	J	540
90	280M	1LE0102-2DA24-1..4	IE 1	2975	289	36.0	121	0.88	93.0	93.2	91.3	7.2	2.8	3	0.82	J	560
110	315S	1LE0102-3AA04-1..4	IE 1	2982	353	37.5	144	0.90	93.3	93.1	91.2	7.5	2.2	3.1	1.4	K	735
132	315M	1LE0102-3AA24-1..4	IE 1	2980	423	35.0	170	0.92	93.5	93.1	91.7	7.5	2.3	2.9	1.7	J	850
160	315L	1LE0102-3AA54-1..4	IE 1	2982	513	42.5	205	0.92	93.8	93.6	92.5	7.6	2.5	2.8	1.9	J	960
185	315L	1LE0102-3AA64-1..4	IE 1	2978	594	38.5	235	0.92	93.9	93.9	93.1	7.5	2.4	2.8	2.3	J	1070
200	315L	1LE0102-3AA74-1..4	IE 1	2980	641	49.0	255	0.92	94.0	94.3	93.2	7.9	2.5	2.6	2.3	K	1080
220	355M	1LE0102-3BA24-1..4	IE 1	2985	704	32.5	280	0.90	94.8	95.0	92.8	6.5	2	2.1	2.9	H	1590
250	355M	1LE0102-3BA34-1..4	IE 1	2985	800	41.5	320	0.90	95.2	95.2	93.0	6.5	2	2.1	3	H	1620
280	355L	1LE0102-3BA54-1..4	IE 1	2985	896	43.5	360	0.90	95.2	95.2	92.9	6.5	2	2.1	3.5	H	1820
315	355L	1LE0102-3BA64-1..4	IE 1	2985	1008	46.5	405	0.90	95.4	95.4	93.2	6.5	2	2.1	3.5	H	1830

Electrical data - 1LE0 - IE1 - 4-pole (IE1 Cast Iron) 1500 rpm 4-pole, 525 VA 50 Hz																	
Rated output kW	Frame size	Article number	IE class	Rated speed rpm	Rated torque Nm	No load current A	Rated current A	Rated power factor	Efficiency at			Starting current	Starting torque	Break-down torque Nm	Moment of inertia kgm ²	Torque class	Net weight (IMB3) kg
									100% load %	75% load %	50% load %						
0.55	80M	1LE0102-0DB24-1..4	-	1415	3.7	0.58	1.08	0.81	69.4	69.9	66.8	4.5	2	2.6	0.0016	D	17.0
0.75	80M	1LE0102-0DB34-1..4	IE 1	1405	5.1	0.75	1.41	0.81	72.1	73.7	71.8	4.8	2	2.6	0.0019	D	18.5
1.1	90S	1LE0102-0EB04-1..4	IE 1	1420	7.4	1.20	2.05	0.80	75.0	77.3	74.3	5.4	2	2.6	0.0027	E	23
1.5	90L	1LE0102-0EB44-1..4	IE 1	1425	10	1.59	2.65	0.81	77.2	77.3	75.1	5.6	2	2.5	0.0034	E	26
2.2	100L	1LE0102-1AB44-1..4	IE 1	1425	14.8	2.05	3.75	0.81	79.7	80.7	78.7	5.8	2.4	2.9	0.0063	E	30
3	100L	1LE0102-1AB54-1..4	IE 1	1420	20.2	2.40	4.85	0.83	81.5	83.1	81.5	6.5	2.8	3.1	0.0081	E	33
4	112M	1LE0102-1BB24-1..4	IE 1	1445	26.4	3.90	6.7	0.79	83.1	83.3	81.5	7.4	2.8	3.3	0.011	M	44
5.5	132S	1LE0102-1CB04-1..4	IE 1	1450	36.2	4.20	8.7	0.82	84.7	85.5	84.3	6.5	2	3.1	0.019	K	59
7.5	132M	1LE0102-1CB24-1..4	IE 1	1435	50	4.90	11.7	0.82	86.0	87.2	87.2	6.4	2.3	3.1	0.025	K	70
11	160M	1LE0102-1DB24-1..4	IE 1	1455	72	7.1	16.3	0.84	87.6	88.5	87.8	6.9	2.2	3.3	0.045	K	99
15	160L	1LE0102-1DB44-1..4	IE 1	1460	98	10.1	22.0	0.84	88.7	89.4	88.6	7.8	2.7	3.8	0.06	L	125
18.5	180M	1LE0102-1EB24-1..4	IE 1	1470	120	10.5	27.0	0.85	89.3	90.3	89.9	7.8	2.7	3.5	0.13	L	163
22	180L	1LE0102-1EB44-1..4	IE 1	1465	143	12.1	31.5	0.85	89.9	90.9	89.9	7.8	2.4	3.2	0.14	L	179
30	200L	1LE0102-2AB44-1..4	IE 1	1470	195	17.4	42.5	0.85	90.7	91.6	90.5	7.4	2.4	3.1	0.22	K	235
37	225S	1LE0102-2BB04-1..4	IE 1	1470	240	17.7	52	0.86	91.2	91.8	91.0	7.3	2.3	2.8	0.44	K	295

SIMOTICS General Purpose (Cast Iron) – IE1

Cast Iron Series						
Efficiency class	IE1			IE2		
Series	1LE0102			1LE0101		
No. of poles	2	4	6	2	4	6
Cooling	Self-ventilated (IC 411)			Self-ventilated (IC 411)		
Degree of protection	IP55			IP55		
Insulation	Thermal class 155(F)			Thermal class 155(F)		
Utilization	Thermal class 130(B)			Thermal class 130(B)		
Frame size	80 ... 355			80 ... 355		
Rated output at 50 Hz	0.55 ... 315 kW			0.55 ... 315 kW		
Rated torque at 50 Hz	2.6 ... 2414 Nm			2.6 ... 2412 Nm		

Electrical data - 1LE0 - IE1 - 4-pole (IE1 Cast Iron) 1500 rpm 4-pole, 525 VΔ 50 Hz																	
Rated output kW	Frame size	Article number	IE class	Rated speed rpm	Rated torque Nm	No load current A	Rated current A	Rated power factor	Efficiency at			Starting current	Starting torque	Break-down torque Nm	Moment of inertia kgm ²	Torque class	Net weight (IMB3) kg
									100% load %	75% load %	50% load %						
45	225M	1LE0102-2BB24-1..4	IE 1	1475	292	21.5	62	0.87	91.7	92.4	92.0	7.8	2.9	3.3	0.5	K	322
55	250M	1LE0102-2CB24-1..4	IE 1	1478	356	24.5	77	0.86	92.1	92.8	92.0	7.6	3	2.8	0.8	K	410
75	280S	1LE0102-2DB04-1..4	IE 1	1480	484	32.0	101	0.88	92.7	93.3	92.2	7.2	2.6	2.8	1.3	J	540
90	280M	1LE0102-2DB24-1..4	IE 1	1485	579	44.0	121	0.88	93.0	93.5	92.2	7.8	2.7	2.8	1.4	K	600
110	315S	1LE0102-3AB04-1..4	IE 1	1490	706	54	153	0.85	93.3	93.4	92.5	8.6	2.8	3.1	2.2	L	745
132	315M	1LE0102-3AB24-1..4	IE 1	1488	848	45.5	177	0.87	93.5	93.8	93.4	7.3	2.5	2.7	2.5	J	875
160	315L	1LE0102-3AB54-1..4	IE 1	1488	1030	63	215	0.87	93.8	94.0	93.6	7.4	3	2.9	3	K	950
185	315L	1LE0102-3AB64-1..4	IE 1	1490	1185	70	245	0.88	93.9	94.1	93.6	7.6	3	2.9	3.6	K	1060
200	315L	1LE0102-3AB74-1..4	IE 1	1488	1285	64	265	0.88	94.0	94.3	94.1	7.4	3	3	3.7	J	1070
220	355M	1LE0102-3BB24-1..4	IE 1	1490	1410	45.0	290	0.87	95.0	95.1	93.1	6.5	2.1	2.2	6.6	H	1630
250	355M	1LE0102-3BB34-1..4	IE 1	1490	1602	45.5	330	0.87	95.2	95.2	93.6	6.5	2.1	2.2	6.9	H	1650
280	355L	1LE0102-3BB54-1..4	IE 1	1490	1795	54	370	0.87	95.2	95.2	93.4	6.5	2.1	2.2	7.7	H	1820
315	355L	1LE0102-3BB64-1..4	IE 1	1490	2019	55	420	0.87	95.2	95.3	93.6	6.5	2.1	2.2	8.5	H	1890

Electrical data - 1LE0 - IE1 - 6-pole (IE1 Cast Iron) 1000 rpm 6-pole, 525 VΔ 50 Hz																	
Rated output kW	Frame size	Article number	IE class	Rated speed rpm	Rated torque Nm	No load current A	Rated current A	Rated power factor	Efficiency at			Starting current	Starting torque	Break-down torque Nm	Moment of inertia kgm ²	Torque class	Net weight (IMB3) kg
									100% load %	75% load %	50% load %						
0.55	80M	1LE0102-ODC34-1..4	-	910	5.8	0.79	1.21	0.74	67.5	68.7	65.6	3.8	2.1	2.4	0.0024	C	18.0
0.75	90S	1LE0102-OEC04-1..4	IE 1	925	7.7	0.97	1.59	0.74	70.0	71.5	68.9	3.9	2	2.5	0.0028	C	25
1.1	90L	1LE0102-OEC44-1..4	IE 1	935	11.3	1.44	2.30	0.73	72.9	74.0	71.8	4.4	2.2	2.7	0.0038	D	26
1.5	100L	1LE0102-1AC44-1..4	IE 1	940	15.4	1.74	2.90	0.76	75.2	77.2	74.7	4.6	2.1	2.6	0.0074	D	32
2.2	112M	1LE0102-1BC24-1..4	IE 1	940	22.3	2.30	4.15	0.75	77.7	79.2	78.1	5.2	2.4	3	0.01	E	42
3	132S	1LE0102-1CC04-1..4	IE 1	955	30	3.15	5.7	0.73	79.7	80.9	79.3	5.2	2	2.8	0.018	E	55
4	132M	1LE0102-1CC24-1..4	IE 1	955	40	4.70	7.4	0.73	81.4	82.2	79.4	5.6	2.1	2.9	0.023	K	65
5.5	132M	1LE0102-1CC34-1..4	IE 1	955	55	5.6	9.8	0.74	83.1	84.2	83.0	6	2.3	3.2	0.029	K	73
7.5	160M	1LE0102-1DC24-1..4	IE 1	965	74	7.0	12.8	0.76	84.7	85.4	84.5	5.8	2	2.9	0.052	K	101
11	160L	1LE0102-1DC44-1..4	IE 1	965	109	10.1	18.5	0.76	86.4	87.0	86.0	6.6	2.2	3.1	0.072	K	128
15	180L	1LE0102-1EC44-1..4	IE 1	970	148	10.8	24.5	0.78	87.7	88.7	88.4	6.5	2.3	3	0.18	K	169
18.5	200L	1LE0102-2AC44-1..4	IE 1	975	182.1	10.0	28.0	0.82	88.6	90.0	90.1	5.8	2.2	2.8	0.26	J	218
22	200L	1LE0102-2AC54-1..4	IE 1	975	215	11.4	33.0	0.82	89.2	90.5	90.5	6.5	2.3	2.8	0.31	J	237
30	225M	1LE0102-2BC24-1..4	IE 1	978	293	17.4	44.0	0.83	90.2	91.4	90.5	6.7	2.4	2.8	0.6	K	290
37	250M	1LE0102-2CC24-1..4	IE 1	982	360	20.0	54	0.83	90.8	91.5	91.2	7.5	3	2.8	0.89	K	389
45	280S	1LE0102-2DC04-1..4	IE 1	985	437	21.5	64	0.85	91.4	92.4	92.3	7.1	2.5	2.8	1.1	K	500
55	280M	1LE0102-2DC24-1..4	IE 1	988	532	27.0	77	0.85	91.9	92.6	92.4	7.5	2.4	2.7	1.4	K	525
75	315S	1LE0102-3AC04-1..4	IE 1	988	725	42.0	107	0.83	92.6	93.0	92.4	7.5	2.4	3	2.3	K	675
90	315M	1LE0102-3AC24-1..4	IE 1	986	872	41.5	127	0.84	92.9	93.4	93.2	7	2.3	2.8	2.8	K	830
110	315L	1LE0102-3AC54-1..4	IE 1	986	1066	43.5	152	0.86	93.3	93.9	93.8	6.5	2.2	2.7	3.4	J	915
132	315L	1LE0102-3AC64-1..4	IE 1	988	1278	59	181	0.86	93.5	94.2	93.6	7.8	2.2	2.4	3.9	K	1010
160	355M	1LE0102-3BC24-1..4	IE 1	989	1545	40.5	210	0.88	94.5	94.6	92.4	6.5	2	2.1	7.7	H	1640
185	355M	1LE0102-3BC34-1..4	IE 1	989	1786	42.0	240	0.88	94.5	94.6	92.6	6.5	2	2.1	8.4	H	1680
200	355M	1LE0102-3BC44-1..4	IE 1	989	1931	45.5	260	0.88	94.7	94.7	93.4	6.5	2	2.1	9.1	H	1720
220	355L	1LE0102-3BC54-1..4	IE 1	989	2124	52	290	0.88	94.7	94.7	92.6	6.5	2	2.1	10.1	H	1840
250	355L	1LE0102-3BC64-1..4	IE 1	989	2414	61	330	0.88	94.7	94.7	93.4	6.5	2	2.1	11.4	H	1920



The nominal torque of the motor is easy to calculate;
Torque (Nm) =
Power (kW) x 9550 / Speed (rpm).

SIMOTICS General Purpose (Cast Iron) – IE2

	Cast Iron Series					
Efficiency class	IE1			IE2		
Series	1LE0102			1LE0101		
No. of poles	2	4	6	2	4	6
Cooling	Self-ventilated (IC 411)			Self-ventilated (IC 411)		
Degree of protection	IP55			IP55		
Insulation	Thermal class 155(F)			Thermal class 155(F)		
Utilization	Thermal class 130(B)			Thermal class 130(B)		
Frame size	80 ... 355			80 ... 355		
Rated output at 50 Hz	0.55 ... 315 kW			0.55 ... 315 kW		
Rated torque at 50 Hz	2.6 ... 2414 Nm			2.6 ... 2412 Nm		

Electrical data - 1LE0 - IE2 - 2-pole (IE2 Cast Iron) 3000 rpm 2-pole, 525 VA 50 Hz																	
Rated output kW	Frame size	Article number	IE class	Rated speed rpm	Rated torque Nm	No load current A	Rated current A	Rated power factor	Efficiency at load %			Starting current torque		Break-down torque Nm	Moment of inertia kgm ²	Torque class	Net weight (IMB3) kg
									100%	75%	50%	cur-	torque				
0.75	80M	1LE0101-ODA24-1..4	IE 2	2795	2.6	0.54	1.27	0.84	77.4	78.5	78.5	5.6	2.4	2.4	0.00080	D	15.5
1.1	80M	1LE0101-ODA34-1..4	IE 2	2835	3.7	0.86	1.81	0.84	79.6	80.6	77.4	6.0	2.8	3.2	0.0012	E	17.5
1.5	90S	1LE0101-OEA04-1..4	IE 2	2890	5.0	1.16	2.40	0.84	81.3	81.7	78.0	6.5	2.4	3.1	0.0021	E	23
2.2	90L	1LE0101-OEA44-1..4	IE 2	2890	7.3	1.74	3.45	0.85	83.2	83.7	80.8	7.2	2.6	3.5	0.0026	F	26
3	100L	1LE0101-1AA44-1..4	IE 2	2885	9.9	2.15	4.65	0.84	84.6	85.1	84.1	7.5	4	4.5	0.0036	F	34
4	112M	1LE0101-1BA24-1..4	IE 2	2930	13.0	2.80	5.9	0.86	85.8	86.6	84.7	7.5	2.2	2.9	0.0064	L	40
5.5	132S	1LE0101-1CA04-1..B4	IE 2	2930	17.9	3.25	8.0	0.87	87.0	87.6	86.9	7.5	2.2	2.9	0.014	K	56
7.5	132S	1LE0101-1CA14-1..B4	IE 2	2930	24.4	3.55	10.5	0.89	88.1	88.8	88.5	7.5	2.3	2.9	0.017	K	62
11	160M	1LE0101-1DA24-1..B4	IE 2	2935	35.8	6.2	15.6	0.86	89.4	90.1	89.3	7.5	2.2	2.9	0.031	K	96
15	160M	1LE0101-1DA34-1..B4	IE 2	2935	48.8	7.9	21.5	0.86	90.3	91.0	90.5	7.5	2.4	3.2	0.038	K	106
18.5	160L	1LE0101-1DA44-1..B4	IE 2	2935	60.2	7.8	25.0	0.89	90.9	91.7	91.5	7.5	2.4	3.2	0.046	K	125
22	180M	1LE0101-1EA24-1..B4	IE 2	2935	71.6	10.3	30.5	0.87	91.3	91.8	91.1	7.6	2.5	3.2	0.072	K	152
30	200L	1LE0101-2AA44-1..B4	IE 2	2955	97.0	13.7	42.0	0.86	92.0	92.3	91.5	7.5	2.5	3.2	0.13	K	229
37	200L	1LE0101-2AA54-1..B4	IE 2	2955	120	14.5	50	0.88	92.5	92.8	92.3	7.5	2.5	3.2	0.15	K	245
45	225M	1LE0101-2BA24-1..B4	IE 2	2965	145	17.4	61	0.88	92.9	93.1	92.5	7.9	2.5	3.1	0.24	K	307
55	250M	1LE0101-2CA24-1..B4	IE 2	2970	177	21.5	74	0.88	93.2	93.2	91.8	7.5	2.5	3	0.42	K	378
75	280S	1LE0101-2DA04-1..B4	IE 2	2975	241	31.0	101	0.87	93.8	93.8	92.7	7.5	2.8	3	0.75	K	550
90	280M	1LE0101-2DA24-1..B4	IE 2	2978	289	37.5	121	0.87	94.1	94.1	92.9	7.5	3	3.1	0.88	K	570
110	315S	1LE0101-3AA04-1..B4	IE 2	2982	352	36.0	143	0.90	94.3	94.3	93.3	7.5	2.2	2.6	1.4	J	740
132	315M	1LE0101-3AA24-1..B4	IE 2	2982	423	35.5	170	0.91	94.6	94.6	93.9	7.5	2.3	2.9	1.7	J	855
160	315L	1LE0101-3AA54-1..B4	IE 2	2982	512	39.5	205	0.92	94.8	95.1	94.1	7.5	2.5	2.8	1.9	J	970
185	315L	1LE0101-3AA64-1..B4	IE 2	2982	592	48.5	230	0.92	95.0	95.3	94.2	7.5	2.5	2.8	2.3	J	1080
200	315L	1LE0101-3AA74-1..B4	IE 2	2982	641	48.5	255	0.92	95.0	95.3	94.4	7.5	2.5	2.8	2.3	J	1090
220	355M	1LE0101-3BA24-1..B4	IE 2	2980	705	38.5	280	0.90	95.0	95.0	92.8	7.1	2	2.2	2.9	J	1600
250	355M	1LE0101-3BA34-1..B4	IE 2	2980	801	35.0	320	0.90	95.0	95.0	93.0	7.1	2	2.2	3	J	1650
280	355L	1LE0101-3BA54-1..B4	IE 2	2980	897	42.5	360	0.90	95.0	95.1	93.0	7.1	2	2.2	3.5	J	1830
315	355L	1LE0101-3BA64-1..B4	IE 2	2980	1009	43.5	405	0.90	95.0	95.1	93.1	7.1	2	2.3	3.5	J	1840

Electrical data - 1LE0 - IE2 - 4-pole (IE2 Cast Iron) 1500 rpm 4-pole, 525 VA 50 Hz																	
Rated output kW	Frame size	Article number	IE class	Rated speed rpm	Rated torque Nm	No load current A	Rated current A	Rated power factor	Efficiency at load %			Starting current torque		Break-down torque Nm	Moment of inertia kgm ²	Torque class	Net weight (IMB3) kg
									100%	75%	50%	cur-	torque				
0.55	80M	1LE0101-0DB24-1..4	-	1425	3.7	0.61	1.01	0.80	74.0	74.7	70.1	6.0	2.0	2.7	0.0021	F	17.5
0.75	80M	1LE0101-0DB34-1..4	IE 2	1440	5.0	0.76	1.38	0.75	79.6	79.6	76.8	6.5	2.8	3.5	0.0027	F	19
1.1	90S	1LE0101-OEB04-1..4	IE 2	1440	7.3	1.22	1.99	0.75	81.4	81.4	77.6	7.0	2.8	3.5	0.0041	G	24
1.5	90L	1LE0101-OEB44-1..4	IE 2	1440	9.9	1.56	2.60	0.76	82.8	82.8	80.2	7.0	3.0	3.8	0.0047	G	27
2.2	100L	1LE0101-1AB44-1..4	IE 2	1435	14.6	1.99	3.60	0.79	84.3	85.0	83.1	7.0	3.0	3.2	0.0081	F	33
3	100L	1LE0101-1AB54-1..4	IE 2	1435	20.0	2.70	4.85	0.79	85.5	86.3	84.2	7.0	3.0	3.2	0.010	F	37
4	112M	1LE0101-1BB24-1..4	IE 2	1445	26.4	3.40	6.4	0.79	86.6	87.1	85.8	7.1	2.7	3.1	0.011	L	45
5.5	132S	1LE0101-1CB04-1..B4	IE 2	1460	36.0	4.65	8.8	0.79	87.7	88.2	86.9	7.5	2.5	3.1	0.021	L	61
7.5	132M	1LE0101-1CB24-1..B4	IE 2	1460	49.1	5.1	11.4	0.82	88.7	89.4	88.8	7.7	2.7	3.2	0.029	L	73
11	160M	1LE0101-1DB24-1..B4	IE 2	1465	71.7	5.1	15.9	0.84	89.8	90.4	90.1	7.5	2.5	3.1	0.051	K	103
15	160L	1LE0101-1DB44-1..B4	IE 2	1465	97.8	9.0	21.5	0.85	90.6	91.3	90.6	7.8	2.7	3.2	0.066	K	130
18.5	180M	1LE0101-1EB24-1..B4	IE 2	1465	121	9.3	26.5	0.85	91.2	91.8	91.8	7.3	2.5	3.2	0.13	K	165
22	180L	1LE0101-1EB44-1..B4	IE 2	1465	143	11.7	31.0	0.85	91.6	92.3	92.7	7.3	2.4	3.2	0.14	K	180
30	200L	1LE0101-2AB44-1..B4	IE 2	1470	195	14.5	42.0	0.85	92.3	92.9	92.9	7.3	2.7	3.2	0.22	K	238
37	225S	1LE0101-2BB04-1..B4	IE 2	1475	240	17.4	51	0.86	92.7	93.2	92.9	7.3	2.7	3.2	0.45	K	298

SIMOTICS General Purpose (Cast Iron) – IE2

Cast Iron Series						
Efficiency class	IE1			IE2		
Series	1LE0102			1LE0101		
No. of poles	2	4	6	2	4	6
Cooling	Self-ventilated (IC 411)			Self-ventilated (IC 411)		
Degree of protection	IP55			IP55		
Insulation	Thermal class 155(F)			Thermal class 155(F)		
Utilization	Thermal class 130(B)			Thermal class 130(B)		
Frame size	80 ... 355			80 ... 355		
Rated output at 50 Hz	0.55 ... 315 kW			0.55 ... 315 kW		
Rated torque at 50 Hz	2.6 ... 2414 Nm			2.6 ... 2412 Nm		

Electrical data - 1LE0 - IE2 - 4-pole (IE2 Cast Iron) 1500 rpm 4-pole, 525 VA 50 Hz																	
Rated output kW	Frame size	Article number	IE class	Rated speed rpm	Rated torque Nm	No load current A	Rated current A	Rated power factor	Efficiency at			Starting		Break-down torque Nm	Moment of inertia kgm ²	Torque class	Net weight (IMB3) kg
									100% load %	75% load %	50% load %	current	torque				
45	225M	1LE0101-2BB24-1.B4	IE 2	1475	291	19.9	61	0.87	93.1	93.5	93.9	7.3	2.7	3.2	0.51	K	322
55	250M	1LE0101-2CB24-1.B4	IE 2	1480	355	24.5	75	0.86	93.5	93.9	93.3	7.5	3.1	3.5	0.8	K	410
75	280S	1LE0101-2DB04-1.B4	IE 2	1485	482	34.5	101	0.87	94.0	94.3	93.9	7.5	2.7	3.1	1.4	K	555
90	280M	1LE0101-2DB24-1.B4	IE 2	1485	579	43.5	121	0.87	94.2	94.3	94.2	7.5	2.7	3.1	1.5	K	610
110	315S	1LE0101-3AB04-1.B4	IE 2	1488	706	51	148	0.86	94.5	94.5	93.9	7.3	2.8	2.9	2.2	K	750
132	315M	1LE0101-3AB24-1.B4	IE 2	1486	848	42.5	174	0.88	94.7	94.7	95.0	7.3	2.5	2.7	2.5	J	875
160	315L	1LE0101-3AB54-1.B4	IE 2	1488	1027	59	210	0.88	94.9	94.9	95.1	7.4	3.0	2.9	3.0	J	960
185	315L	1LE0101-3AB64-1.B4	IE 2	1488	1187	66	240	0.88	95.1	95.1	95.0	7.4	3.0	3.0	3.6	J	1070
200	315L	1LE0101-3AB74-1.B4	IE 2	1488	1284	66	265	0.88	95.1	95.1	95.1	7.4	3.0	3.0	3.7	J	1080
220	355M	1LE0101-3BB24-1.B4	IE 2	1490	1410	53	280	0.90	95.1	95.2	93.3	6.9	2.0	2.2	6.6	J	1640
250	355M	1LE0101-3BB34-1.B4	IE 2	1490	1602	46.5	320	0.90	95.1	95.2	93.8	6.9	2.0	2.2	6.9	J	1680
280	355L	1LE0101-3BB54-1.B4	IE 2	1490	1795	50	360	0.90	95.1	95.2	93.8	6.9	2.0	2.2	7.7	J	1830
315	355L	1LE0101-3BB64-1.B4	IE 2	1490	2019	57	405	0.90	95.1	95.2	93.8	6.9	2.0	2.2	8.5	J	1900

Electrical data - 1LE0 - IE2 - 6-pole (IE2 Cast Iron) 1000 rpm 6-pole, 525 VA 50 Hz																	
Rated output kW	Frame size	Article number	IE class	Rated speed rpm	Rated torque Nm	No load current A	Rated current A	Rated power factor	Efficiency at			Starting		Break-down torque Nm	Moment of inertia kgm ²	Torque class	Net weight (IMB3) kg
									100% load %	75% load %	50% load %	current	torque				
0.55	80M	1LE0101-ODC34-1..4	-	895	5.9	0.83	1.12	0.76	71.0	72.0	68.5	3.8	2.1	2.4	0.0028	C	18.5
0.75	90S	1LE0101-OEC04-1..4	IE 2	935	7.7	0.97	1.52	0.71	75.9	76.5	72.7	3.9	2.0	2.5	0.0038	C	26
1.1	90L	1LE0101-OEC44-1..4	IE 2	945	11.1	1.52	2.15	0.71	78.1	78.1	75.7	4.4	2.2	2.7	0.0046	D	27
1.5	100L	1LE0101-1AC44-1..4	IE 2	945	15.2	1.81	2.80	0.74	79.8	80.1	78.2	4.6	2.1	2.6	0.0086	D	34
2.2	112M	1LE0101-1BC24-1..4	IE 2	950	22.1	2.20	4.05	0.73	81.8	82.5	81.0	5.2	2.4	3.0	0.012	E	44
3	132S	1LE0101-1CC04-1..4	IE 2	960	29.8	2.80	5.4	0.73	83.3	84.3	83.4	5.2	2.0	2.8	0.019	D	56
4	132M	1LE0101-1CC24-1..4	IE 2	960	39.8	3.85	7.1	0.73	84.6	85.4	84.5	5.6	2.1	2.9	0.024	K	66
5.5	132M	1LE0101-1CC34-1.B4	IE 2	960	54.7	5.2	9.4	0.75	86.0	86.6	85.7	6.0	2.3	3.2	0.031	K	75
7.5	160M	1LE0101-1DC24-1.B4	IE 2	965	74.2	6.0	12.3	0.77	87.2	87.9	87.2	5.8	2.0	2.9	0.056	J	104
11	160L	1LE0101-1DC44-1.B4	IE 2	965	109	8.2	17.4	0.78	88.7	89.4	89.5	6.6	2.2	3.1	0.077	K	132
15	180L	1LE0101-1EC44-1.B4	IE 2	975	147	11.3	23.5	0.78	89.7	90.4	89.9	6.5	2.3	3.0	0.18	K	170
18.5	200L	1LE0101-2AC44-1.B4	IE 2	975	181	10.5	28.0	0.81	90.4	91.0	91.8	5.8	2.2	2.8	0.27	J	220
22	200L	1LE0101-2AC54-1.B4	IE 2	975	215	12.5	32.5	0.82	90.9	91.4	91.9	6.5	2.3	2.8	0.32	J	240
30	225M	1LE0101-2BC24-1.B4	IE 2	980	292	14.8	43.5	0.83	91.7	92.3	92.7	6.7	2.4	2.8	0.62	J	294
37	250M	1LE0101-2CC24-1.B4	IE 2	982	360	17.4	53	0.83	92.2	92.8	92.3	7.5	3.0	2.8	0.91	K	394
45	280S	1LE0101-2DC04-1.B4	IE 2	985	436	21.5	63	0.85	92.7	93.3	93.5	7.1	2.5	2.8	1.2	K	510
55	280M	1LE0101-2DC24-1.B4	IE 2	986	533	26.5	77	0.85	93.1	93.7	93.6	7.5	2.4	2.7	1.5	K	535
75	315S	1LE0101-3AC04-1.B4	IE 2	986	726	40.5	104	0.85	93.7	94.3	93.8	7.5	2.4	3.0	2.3	K	680
90	315M	1LE0101-3AC24-1.B4	IE 2	986	872	39.0	124	0.85	94.0	94.5	94.4	7.0	2.3	2.8	2.8	J	835
110	315L	1LE0101-3AC54-1.B4	IE 2	988	1063	43.5	148	0.86	94.3	94.7	94.6	6.5	2.2	2.7	3.9	J	975
132	315L	1LE0101-3AC64-1.B4	IE 2	988	1276	53	177	0.86	94.6	95.0	94.9	7.8	2.2	2.4	4.3	K	1030
160	355M	1LE0101-3BC24-1.B4	IE 2	990	1543	38.5	215	0.87	94.8	95.1	93.5	6.5	2.0	2.1	7.7	J	1650
185	355M	1LE0101-3BC34-1.B4	IE 2	990	1785	43.5	245	0.87	95.0	95.3	93.5	6.5	2.0	2.1	8.4	J	1690
200	355M	1LE0101-3BC44-1.B4	IE 2	990	1929	42.5	270	0.87	95.0	95.3	93.6	6.5	2.0	2.1	9.1	J	1730
220	355L	1LE0101-3BC54-1.B4	IE 2	990	2122	48.5	295	0.87	95.0	95.3	93.5	6.5	2.0	2.1	10.1	J	1850
250	355L	1LE0101-3BC64-1.B4	IE 2	990	2412	56	335	0.87	95.0	95.3	93.5	6.5	2.0	2.1	11.4	J	1930

Distribution Motor Options

Aluminum	Series		
SIMOTICS GP 1LA7 Standard Efficiency IE1	1	available	available
SIMOTICS GP 1LE10 Standard Efficiency IE1	2		
SIMOTICS GP 1LE10 High Efficiency IE2	3	available	
Cast Iron			
SIMOTICS GP 1LE0102 Standard Efficiency IE1	4	available	
SIMOTICS GP 1LE0101 High Efficiency IE2	5	available	

Option Description	Motor Order Code	Series Availability	63	71	80	90	100
Voltage and frequency							
230 VΔ/400 VY, 50 Hz	1LE.....2-2... 1LA7.....1.	2,3,4,5 1	□	□	□	□	□
400 VΔ/690 VY, 50 Hz	1LE.....3-4...	2,3,4,5	-	-	-	-	□
220 VΔ/380 VY, 50 Hz	1LE.....2-1... 1LA7.....9.	L1R 2,3,4,5 1	✓	✓	✓	✓	✓
380 VΔ/660 VY, 50 Hz	1LE010.....3-3...	2,3,4,5	-	-	-	-	✓
415 VY, 50 Hz	1LE010.....2-3... 1LA7.....9.	L1C 2,3,4,5 1	✓	✓	✓	✓	✓
415 VΔ, 50 Hz	1LE010.....3-5...	2,3,4,5	-	-	-	-	✓
525 VΔ, 50 Hz	1LE010.....4-1... 1LA7.....9.	L1Y 2,3,4,5 1	✓	✓	✓	✓	✓
Type of construction							
IM B3	1LE.....A... 1LA7.....0	2,3,4,5 1	□	□	□	□	□
IM B35	1LE.....J... 1LA7.....6	2,3,4,5 1	✓	✓	✓	✓	✓
IM B5	1LE.....F... 1LA7.....1	2,3,4,5 1	✓	✓	✓	✓	✓
IM V1 ^(a)	1LE.....G... 1LA7.....1	2,3,4,5 1	✓	✓	✓	✓	✓
IM B14	1LE.....K... 1LA7.....2	2,3,4,5 1	✓	✓	✓	✓	✓
Mechanical design and degrees of protection							
Condensation drain holes	1LE.....-Z 1LA7.....-Z	H03 L12 2,3,4,5 1	◇	◇	◇	◇	◇
Drive-end seal for flange-mounting motors, oil-tight to 0.1 bar	1LE.....-Z 1LA7.....-Z	H23 K17 2,3 1	✓	✓	✓	✓	✓
Prepared for mountings, center hole only	1LE.....-Z	G40 2,3,5	-	-	□ 5	□ 5	✓ 2, 3 □ 5
Heating and ventilation							
Anti-condensation heating for 230 V	1LE.....-Z 1LA7.....-Z	Q02 K45 2,3,4,5 1	✓	✓	✓	✓	✓
Anti-condensation heating for 115 V	1LE.....-Z 1LA7.....-Z	Q03 K46 2,3,4,5 1	✓	✓	✓	✓	✓
Sheet metal fan cover	1LE1.....-Z 1LE0..... 1LA7.....	F74 2, 3 4, 5 1	□	□	□ 1, 4, 5 ✓ 3	□ 1, 4, 5 ✓ 3	✓ 2, 3 □ 4, 5
Motor protection							
Without protection	1LE.....A... 1LA7.....	2,3,4,5 1	□	□	□	□	□
Motor protection with PTC thermistor with 1 or 3 embedded temperature sensors for tripping ^(d)	1LE.....B... 1LA7.....-Z	A11 2,3,4,5 1	✓	✓	✓	✓	✓
Bearing and lubrication							
Bearing design for increased cantilever forces	1LE.....-Z	L22 2,3,4,5	-	-	-	-	✓
Regreasing device	1LE.....-Z	L23 2,3,4,5	-	-	-	-	✓
Packing, safety notes, documentation and certificate							
Extra rating plate for voltage tolerance ^(e)	1LE1.....-Z 1LE0..... 1LA7.....-Z	B07 2,3 4,5 1	✓	✓	✓ 1, 3 □ 4, 5	✓ 1, 3 □ 4, 5	✓ 2, 3 □ 4, 5
Acceptance test certificate 3.1 in accordance with EN 10204 (routine test)	1LE.....-Z 1LA7.....-Z	B02 B02 2,3,4,5 1	✓	✓	✓	✓	✓

- Standard
- ✓ Option in distribution portfolio
- ◇ Not available in distribution portfolio, only from standard catalog
- Not available
- ^(a) For canopy as modification, please see chapter 8
- ^(b) Standard for 4-pole and 6-pole motor, optional for 2-pole motor



The most common features are already embedded in our distribution motors, such as metal fan cover, 3 x PTC, etc. In addition you can also enjoy an exclusive package price on 1LE0. When you place the order, you simply add these standard features in the article number according to the option guideline below. Our 1LE0 series already include all embedded features in the basic article number.

available			available						available
available			available						available
112	132	160	180	200	225	250	280	315	355
<input type="checkbox"/>	<input type="checkbox"/>	-	-	-	-	-	-	-	-
<input type="checkbox"/>	<input type="checkbox"/>	<input type="checkbox"/>	<input type="checkbox"/>	<input type="checkbox"/>	<input type="checkbox"/>	<input type="checkbox"/>	<input type="checkbox"/>	<input type="checkbox"/>	<input type="checkbox"/>
✓	✓	-	-	-	-	-	-	-	-
✓	✓	✓	✓	✓	✓	✓	✓	✓	✓
✓	✓	-	-	-	-	-	-	-	-
✓	✓	✓	✓	✓	✓	✓	✓	✓	✓
✓	✓	✓	✓	✓	✓	✓	✓	✓	✓
<input type="checkbox"/>	<input type="checkbox"/>	<input type="checkbox"/>	<input type="checkbox"/>	<input type="checkbox"/>	<input type="checkbox"/>	<input type="checkbox"/>	<input type="checkbox"/>	<input type="checkbox"/>	<input type="checkbox"/>
✓	✓	✓	✓	✓	✓	✓	✓	✓	✓
✓	✓	✓	✓	✓	✓	✓	✓	✓	-
✓	✓	✓	✓	✓	✓	✓	✓	✓	✓
✓	✓	✓	-	-	-	-	-	-	-
<input checked="" type="checkbox"/> 2, 3 <input type="checkbox"/> 4, 5	<input checked="" type="checkbox"/> 2, 3 <input type="checkbox"/> 4, 5	<input checked="" type="checkbox"/> 2, 3 <input type="checkbox"/> 4, 5	<input type="checkbox"/>	<input type="checkbox"/>	<input type="checkbox"/>	<input type="checkbox"/>	<input type="checkbox"/>	<input type="checkbox"/>	<input type="checkbox"/>
✓	✓	✓	-	-	-	-	-	-	-
<input checked="" type="checkbox"/> 2, 3 <input type="checkbox"/> 5	<input checked="" type="checkbox"/> 2, 3 <input type="checkbox"/> 5	<input checked="" type="checkbox"/> 2, 3 <input type="checkbox"/> 5	<input type="checkbox"/> 5	<input type="checkbox"/> 5	<input type="checkbox"/> 5	<input type="checkbox"/> 5	<input type="checkbox"/> 5	<input type="checkbox"/> 5	<input type="checkbox"/> 5
✓	✓	✓	✓	✓	✓	✓	✓	✓	✓
✓	✓	✓	✓	✓	✓	✓	✓	✓	✓
<input checked="" type="checkbox"/> 2, 3 <input type="checkbox"/> 4, 5	<input checked="" type="checkbox"/> 2, 3 <input type="checkbox"/> 4, 5	<input checked="" type="checkbox"/> 2, 3 <input type="checkbox"/> 4, 5	<input type="checkbox"/>	<input type="checkbox"/>	<input type="checkbox"/>	<input type="checkbox"/>	<input type="checkbox"/>	<input type="checkbox"/>	<input type="checkbox"/>
<input type="checkbox"/>	<input type="checkbox"/> 2, 3, 4 - 5	<input type="checkbox"/> 2, 3, 4 - 5	<input type="checkbox"/> 4 - 5	<input type="checkbox"/> 4 - 5	<input type="checkbox"/> 4 - 5	<input type="checkbox"/> 4 - 5	<input type="checkbox"/> 4 - 5	<input type="checkbox"/> 4 - 5	<input type="checkbox"/> 4 - 5
✓	<input checked="" type="checkbox"/> 2, 3, 4 <input type="checkbox"/> 5	<input checked="" type="checkbox"/> 2, 3, 4 <input type="checkbox"/> 5	<input checked="" type="checkbox"/> 4 <input type="checkbox"/> 5	<input checked="" type="checkbox"/> 4 <input type="checkbox"/> 5	<input checked="" type="checkbox"/> 4 <input type="checkbox"/> 5	<input checked="" type="checkbox"/> 4 <input type="checkbox"/> 5	<input checked="" type="checkbox"/> 4 <input type="checkbox"/> 5	<input checked="" type="checkbox"/> 4 <input type="checkbox"/> 5	<input checked="" type="checkbox"/> 4 <input type="checkbox"/> 5
<input checked="" type="checkbox"/> 2, 3, 4 <input type="checkbox"/> 5 ^(b)	<input checked="" type="checkbox"/> 2, 3, 4 <input type="checkbox"/> 5 ^(b)	<input checked="" type="checkbox"/> 2, 3, 4 <input type="checkbox"/> 5 ^(b)	✓	✓	✓	✓ ^(c)	✓ ^(c)	✓ ^(c)	✓ ^(c)
✓	✓	✓	✓	✓	✓	✓	<input type="checkbox"/>	<input type="checkbox"/>	<input type="checkbox"/>
<input checked="" type="checkbox"/> 2, 3 <input type="checkbox"/> 4, 5	<input checked="" type="checkbox"/> 2, 3 <input type="checkbox"/> 4, 5	<input checked="" type="checkbox"/> 2, 3 <input type="checkbox"/> 4, 5	<input type="checkbox"/>	<input type="checkbox"/>	<input type="checkbox"/>	<input type="checkbox"/>	<input type="checkbox"/>	<input type="checkbox"/>	<input type="checkbox"/>
✓	✓	✓	✓	✓	✓	✓	✓	✓	✓

(c) Not available for construction type IM V1

(d) For 1LE10 motors, frame sizes 80 and 90, there is only 1 embedded PTC

(e) Option B07 is standard for 400 V version only



Did you know

Power

Power is the work performed in a unit of time, measured in W (Watt).

Dimensions:

$$\begin{aligned}
 1 \text{ W} &= \text{J/s (1 Joule per second)} \\
 &= 1 \text{ Nm/s (1 Newton meter per second)} \\
 &= 1 \text{ kgm}^2/\text{s}^3 \\
 &= 0.102 \text{ kpm/s} \\
 1 \text{ kW} &= 1.36 \text{ HP}
 \end{aligned}$$

The following applies to three-phase motors:

$$P_N = \sqrt{3} \cdot V_{\text{supply}} \cdot I_{\text{supply}} \cdot \eta \cdot \cos\varphi$$

P_N	Rated power in W
V	Rated voltage in V
I	Line current in A
η	Efficiency
$\cos\varphi$	Power factor

The rated power is one of the most important parameters of a motor. According to DIN 42673 – and maintaining the regulations according to VDE 0530 – the individual motor frame sizes are assigned specific power ratings for continuous duty S1. Different operating conditions or different duty types generally result in a change in the rated power.



Did you know

Torque

Torque is generated by the effect of force applied to a lever arm. This is the product of force multiplied by the vertical distance from the axis of rotation; for belt drives, e.g. circumferential force multiplied by the radius of the belt pulley.

$$M = 9.55 \cdot P \cdot \frac{1000}{n}$$

M	Torque in Nm
P	Power in kW
n	Speed in rpm



Did you know

Speed

The synchronous speed n_s (rpm) of a three-phase induction motor is obtained from the line frequency f and the pole pair number p (4-pole $\rightarrow 2p = 4$).

$$n_s = \frac{120 \cdot f}{2 \cdot p}$$

When connected to a 50 Hz line supply, a 2p = 4-pole motor has a synchronous speed of

$$\frac{120 \cdot 50}{4} = 1500 \text{ rpm}$$

The synchronous speeds of the generally used 2, 4, and 6-pole motors are correspondingly obtained

- at a line frequency of 50 Hz
3000, 1500, 1000 rpm
- at a line frequency of 60 Hz
3600, 1800, 1200 rpm

The rotor of a three-phase induction motor rotates with a lower speed (with slip) than the rotating field.

Slip s is calculated according to the following formula:

$$s = \frac{n_s - n}{n_s} \cdot 100$$

s	Slip as a %
n_s	Synchronous speed in rpm
n	Rotor speed in rpm

The rated slip s_N is correspondingly calculated. The rotor losses of the motor are approximately proportional to the slip. The objective is to achieve a low rated slip in order to achieve a good efficiency.

The rated slip depends on the motor size. For instance, for small motors, it is approx. 10 % and for large motors, approx. 1 %.

Notes

Efficiency

Efficiency classes and efficiencies according to IEC 60034-30:2008

Harmonization of the efficiency classes

Different energy efficiency standards exist worldwide for induction motors. To promote international harmonization, the international standard IEC 60034-30:2008 (Rotating electrical machines – Part 30: Efficiency classes of single-speed, three-phase, cage-induction motors (IE code)) was created. This groups low-voltage asynchronous motors into new efficiency classes (valid since October 2008). The efficiencies of IEC 60034-30:2008 are based on losses determined in accordance with the IEC 60034-2-1:2007 standard. This has been valid since November 2007 and has been replacing the standard IEC 60034-2:1996 since November 2010. The supplementary losses are now measured and no longer added as a percentage.

IE efficiency classes

The efficiency classes are grouped according to the following nomenclature (IE = International Efficiency):

- IE1 (Standard Efficiency)
- IE2 (High Efficiency)
- IE3 (Premium Efficiency)
- IE4 (Super Premium Efficiency)

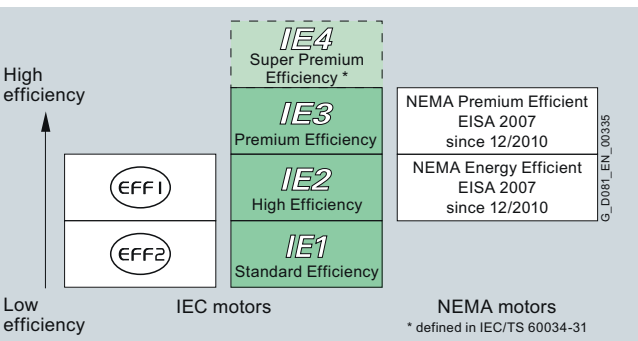

IE efficiency classes in accordance with the output

Measuring method according to IEC 60034-2-1:2007 for determining the efficiency

With the measuring method, the supplementary losses are no longer applied as a percentage, but instead they are determined with measurements (IEC 60034-2-1: 2007). The nominal efficiencies are therefore reduced from EFF1 to IE2 and from EFF2 to IE1, even though there have been no technical or physical changes to the motors.

Previously: $P_{LL} = 0.5 \% \text{ of } P$

Now: $P_{LL} = \text{Individual measurement}$

P_{LL} = Load-dependent supplementary losses

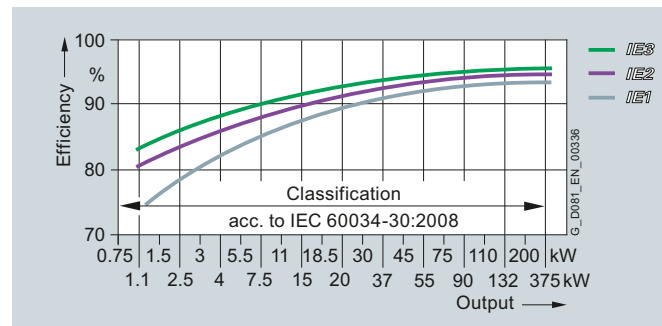

IE1 to IE3 efficiencies 4-pole 50 Hz

The following table shows examples of the efficiency values according to the current and previous loss calculating methods.

	EFF measuring method (incl. percentage losses)	Losses determined according to IEC 60034-2-1: 2007	Losses determined according to IEC 60034-2-1: 2007
5.5 kW 4-pole	89.2 %	87.7 %	89.5 %
45 kW 4-pole	93.9 %	93.1 %	93.6 %
110 kW 4-pole	Not defined	94.5 %	95.0 %

Background information

Comprehensive laws have been introduced in the European Union with the objective of reducing energy consumption and therefore CO₂ emissions. EU Directive 640/2009 concerns the energy consumption or efficiency of induction motors in the industrial environment. This Directive is now in force in every country of the European economic area. For further details on internationally applicable standards and legal requirements, visit:

www.siemens.com/international-efficiency

www.siemens.com/energysaving

www.siemens.com/sinasave

TIP

We comply with the latest efficiency standards and describe motors for both the IE1 and IE2 efficiencies. Although Siemens also has ranges for IE3 and specific solutions for IE4 efficiency, these are still considered specialized and are not described in this document. In addition to these general IE1 and IE2 solutions, Siemens can also provide specific variants for specific markets i.e. in India, Korea, China etc. In such instances please consult your local Siemens representative.



Did you know

The better the efficiency of a motor, the lower the internal heat loss. The lower the heat loss, the lower the temperature rise.

Higher efficiency IE2 motors run cooler than same size IE1 motors. That increases the electrical life expectancy of an IE2 motor.

The most important changes at a glance:

	CEMEP voluntary EU agreement	EU Directive No. 640/2009 adopted on July 22, 2009 based on the IEC 60034-30 standard
Description	Voluntary agreement between the EU commission and the European sector committee of manufacturers of electrical machines (CEMEP)	The EU Directive is in force in every country of the EU. Losses are determined and therefore the efficiency is determined in accordance with IEC 60034-2-1:2007
Number of poles	2, 4	2, 4, 6
Power range	1.1 ... 90 kW	0.75 ... 375 kW
Level	EFF3 – Standard – EFF3 EFF2 – Enhanced efficiency EFF1 – Highly efficient	IE1 – Standard Efficiency IE2 – High Efficiency IE3 – Premium Efficiency
Voltage	400 V, 50 Hz	< 1000 V, 50/60 Hz
Degree of protection	IP5X	All
Motors equipped with a brake	NO	In agreement
Geared motors	NO	YES
Ex motors	NO	EU Directive – NO IEC 60034-30 – YES (but explosion protection always has a higher priority)
Validity	Voluntary agreement; will be replaced on implementation	IEC 60034-30 standard, valid since October 2008; the EU Directive will come into force on June 16, 2011. This means that as of this date, manufacturers are no longer permitted to place IE1 motors on the market in the European economic area.

Exceptions to the EU Directive

- Motors that are designed to be operated totally submerged in a liquid;
- Motors fully integrated into a product (e.g. a gear unit, pump, fan or compressor) whose energy efficiency cannot be measured independently of the product;
- Motors that are specially designed for operation under the following conditions:
 - At altitudes greater than 1000 meters above sea level;
 - At ambient temperatures above 40 °C;
 - At maximum operating temperatures above 400 °C;
 - At ambient temperatures below -15 °C (any motor)
 - With cooling liquid temperatures at the product intake of below 5 °C or above 25 °C;
 - In hazardous areas in the context of Directive 94/9/EC of the European Parliament and Council;
- Brake motors

The following motors are not involved:

- 8-pole motors
- Pole-changing motors
- Synchronous motors
- Motors for intermittent duty S2 to S9
- Single-phase motors
- Motors specially developed for converter-fed operation in accordance with IEC 60034-25

The changes are applicable starting the following dates:

June 16, 2011:

Compliance with the legally required minimum efficiency class IE2 for induction motors in S1 operation in accordance with EU Directive

January 1, 2015:

Compliance with the legally required minimum efficiency class IE3 for outputs from 7.5 to 375 kW or, as an alternative, IE2 motor plus frequency converter

January 1, 2017:

Compliance with the legally required minimum efficiency class IE3 for outputs from 0.75 to 375 kW or, as an alternative, IE2 motor plus frequency converter

IP rating

The IP Code (or Ingress Protection Rating, sometimes also interpreted as International Protection Rating) consists of the letters IP followed by two digits or one digit and one letter and an optional letter. As defined in [international standard IEC 60529](#), IP Code classifies and rates the degrees of protection provided against the intrusion of solid objects, dust, accidental contact, and water in mechanical casings and with electrical enclosures.

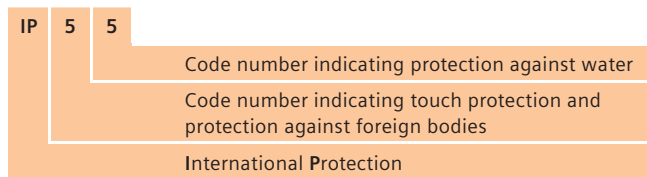

TIP

Some manufacturers offer sealing and protection above IP55. Although it is available as an option, Siemens prefers a true IP55 as a default standard.

- IP55 covers the vast majority of applications as it offers dust and rain protection
- The IP55 is stable over the life of the motor. Higher protections can need maintenance or an exact assembly to ensure that the higher protection is real and not just on paper.
- Modifications can be made on an IP55 motor whilst maintaining that degree of protection.

Solids, first digit

The first digit indicates the level of protection that the enclosure provides against access to hazardous parts (e.g., electrical conductors, moving parts) and the ingress of solid foreign objects.

Level	Object size protected against	Effective against
0	–	No protection against contact and ingress of objects
1	>50 mm	Any large surface of the body, such as the back of a hand, but no protection against deliberate contact with a body part
2	>12.5 mm	Fingers or similar objects
3	>2.5 mm	Tools, thick wires, etc.
4	>1 mm	Most wires, screws, etc.
5	Dust protected	Ingress of dust is not entirely prevented, but it must not enter in sufficient quantity to interfere with the satisfactory operation of the equipment; complete protection against contact
6	Dust tight	No ingress of dust; complete protection against contact

TIP

A suitable degree of protection should be selected depending on the operating and environmental conditions. Siemens offers a standard which is most suitable and applicable over the lifetime of a motor such as true IP55 standard.

Liquids, second digit

Protection of the equipment inside the enclosure against harmful ingress of water.

Level	Protected against	Testing for	Details
0	Not protected	–	–
1	Dripping water	Dripping water (vertically falling drops) shall have no harmful effect.	Test duration: 10 minutes Water equivalent to 1 mm rainfall per minute
2	Dripping water when tilted up to 15°	Vertically dripping water shall have no harmful effect when the enclosure is tilted at an angle up to 15° from its normal position.	Test duration: 10 minutes Water equivalent to 3 mm rainfall per minute
3	Spraying water	Water falling as a spray at any angle up to 60° from the vertical shall have no harmful effect.	Test duration: 5 minutes Water volume: 0.7 liters per minute Pressure: 80–100 kN/m ²
4	Splashing water	Water splashing against the enclosure from any direction shall have no harmful effect.	Test duration: 5 minutes Water volume: 10 liters per minute Pressure: 80–100 kN/m ²
5	Water jets	Water projected by a nozzle (6.3 mm) against enclosure from any direction shall have no harmful effects.	Test duration: at least 3 minutes Water volume: 12.5 liters per minute Pressure: 30 kN/m ² at distance of 3 m
6	Powerful water jets	Water projected in powerful jets (12.5 mm nozzle) against the enclosure from any direction shall have no harmful effects.	Test duration: at least 3 minutes Water volume: 100 liters per minute Pressure: 100 kN/m ² at distance of 3 m
7	Immersion up to 1 m	Ingress of water in harmful quantity shall not be possible when the enclosure is immersed in water under defined conditions of pressure and time (up to 1 m of submersion).	Test duration: 30 minutes Immersion at depth of 1 m
8	Immersion beyond 1 m	The equipment is suitable for continuous immersion in water under conditions which shall be specified by the manufacturer. Normally, this will mean that the equipment is hermetically sealed. However, with certain types of equipment, it can mean that water can enter but only in such a manner that it produces no harmful effects.	Test duration: continuous immersion in water Depth specified by manufacturer

Thermal class

The Siemens motors are rated at normal sinusoidal voltage with a class B (130 °C) temperature rise. The windings are rated to class F (155 °C) thus allowing for reserve for the additional losses associated with variable speed drive operation and/or higher ambient temperature and/or overload conditions.

The temperature rise of the winding of the motor is important. It provides a great insight into the design of the motor and its life expectancy. The cooler a motor runs the better its life expectancy and longer its life. Siemens builds motors to a minimum of Class F (155 °C) on all material – continuous operation for a very long life expectancy.

- Class B (130 °C) is the normal utilization – even better.
- Class H (180 °C) is reserved for special application motors.
- Class H motors are considered detrimental for normal use due to the degradation of the overall life expectancy of paint and bearings.
- At class H the outside surface temperature can exceed an unsafe 100 °C.

The more efficient the motor, the less heat it produces – to the extent that modern motors often only run with internal temperatures of 95 °C – much cooler than the limits set by the standards.

Siemens uses double coated wires with DURIGNIT insulation materials and capable varnishes – we consider all components including electrical connections and bearing grease – our motors are true class F under all circumstances – with reserve built in on top.

A claim to class H could be made but that would not reflect the true life expectancy which you would expect.

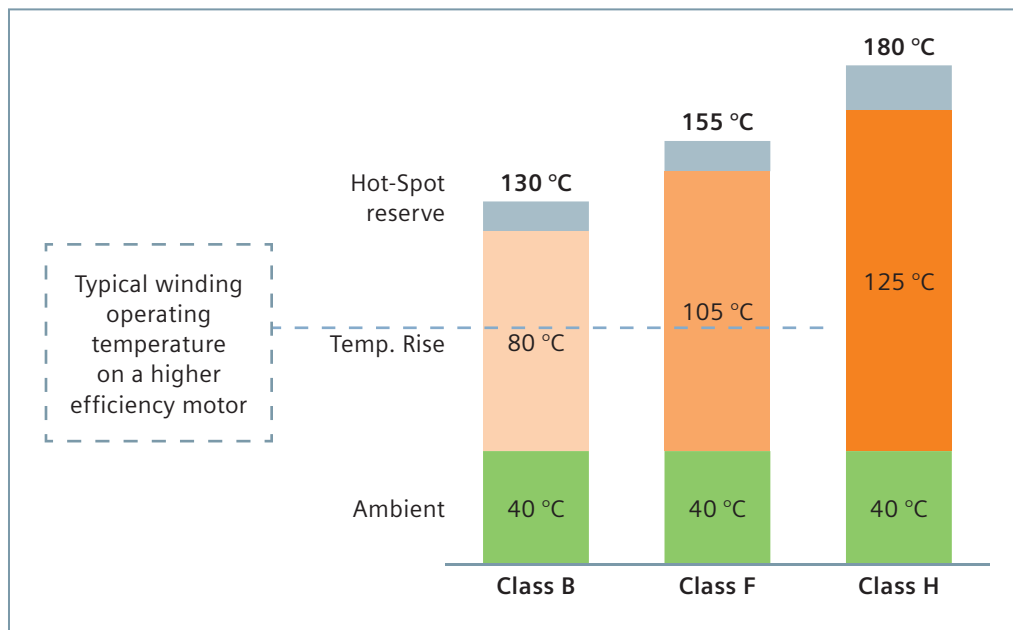

Did you know?

Although Siemens uses class H wire, we do not rate our motors for class H operation. The electrical life expectancy at class F is four times greater than at class H. If used at class B or cooler 400.000 hours and more are not exceptional.

High efficiency motors in IE2 do not generate the amount of heat to reach thermal class H.

TIP

Siemens builds motors with reserve: The motors are capable to operate at least at 155 °C (Class F) but we only rate at a nominal 130 °C (Class B).

- An IE1 motor can be operated at 10% overload or at 50 °C ambient temperature.
- An IE2 motor can be operated at 15% overload or at 55 °C ambient temperature.

Derating

Environmental

- Degree of motor protection IP55 (IEC 60034-5).
- Altitude shall not exceed 1000 m above sea-level (IEC 60034-1).
- Allowed air temperature between -20 °C and 40 °C (IEC 60034-1).
- Permitted relative humidity:
 - -20 °C w T w 20 °C: 100 %
 - 20 °C < T w 30 °C: 95 %
 - 30 °C < T w 40 °C: 55 %

For higher coolant temperatures and / or site altitudes higher than 1000 m above sea level, the specified motor must be reduced by using the factor k_{HT} . This results in an admissible output (P_{adm}) of the motor:

$$P_{adm} = P_{rated} \cdot k_{HT}$$

Reduction factor k_{HT} for different site altitudes and / or coolant temperature

Site altitude above sea level m	Ambient temperature/coolant temperature					
	< 30 °C	30 ~ 40 °C	45 °C	50 °C	55 °C	60 °C
1000	1.07	1.00	0.96	0.92	0.87	0.82
1500	1.04	0.97	0.93	0.89	0.84	0.79
2000	1.00	0.94	0.90	0.86	0.82	0.77
2500	0.96	0.90	0.86	0.83	0.78	0.74
3000	0.92	0.86	0.82	0.79	0.75	0.70
3500	0.88	0.82	0.79	0.75	0.71	0.67
4000	0.82	0.77	0.74	0.71	0.67	0.63

Note:

If operating conditions exceed above values, please contact our local sales office for the selection of catalog motors.

Anti-condensation

Moisture is present in the air around us. Under the correct circumstances it can condensate. The warmer the air the higher the possible moisture content. As air cools the moisture carrying content reduces to the point when the moisture condenses – called the “Dew-Point”.

This condition can be met several times a day under normal operation, as a motor operates and cools at differing times of the day.

Smaller motors are less susceptible than larger motors due to the smaller volume of moist air possible in the motor. Dew moisture condenses and accumulates in a motor, which is seen as water collection. The water accumulates at the lowest point of the motor. It often does no harm as long as the collection point is below the level of the electrical system.

Two points that need to be paid attention to are, first, how much water there is in the air and when it will condensate. The second is, whether it will do any harm.

Relative humidity	Temperature								
	20 °C	30 °C	40 °C	50 °C	60 °C	70 °C	80 °C	90 °C	
10%	2	3	5	8	13	20	29	42	
15%	3	5	8	12	19	30	44	63	
20%	3	6	10	17	26	39	58	84	
25%	4	8	13	21	32	49	73	105	
30%	5	9	15	25	39	59	87	126	
35%	6	11	18	29	45	69	102	146	
40%	7	12	20	33	52	79	116	167	
45%	8	14	23	37	58	89	131	188	
50%	9	15	26	41	65	98	145	209	
55%	10	17	28	46	71	108	160	230	
60%	10	19	31	50	78	118	174	251	
65%	11	20	33	54	84	128	189	272	
70%	12	21	36	58	91	138	203	293	
75%	13	23	38	62	97	148	218	314	
80%	14	24	41	66	104	157	233	335	
85%	15	26	43	70	110	167	247	356	
90%	16	27	46	74	117	177	262	377	
95%	16	29	49	79	123	187	276	398	
100%	17	30	51	83	130	197	291	419	

If operating conditions exceed temperatures of 60 °C, please contact our local sales office for the selection of catalog motors.

Table showing the weight of moisture contained in the air, given as g/m³.

The local temperature is on the x axis and the local relative humidity is shown on the Y axis.

Blue fields show normal conditions.

Yellow fields show higher moisture – for motors FS ≥ 112 a drain hole is recommended.

For orange colored fields a drain hole is recommended and for more important motors a heating is also recommended (separate space heater or winding heating).



TIP In humid climates, during motor cool down the air inside contracts, pulling in fresh, warm, humid air. This humidity condensates inside the motor, forming water droplets. Those water droplets have to drain.

Therefore on many motors, especially the larger ones, Siemens has foreseen drain holes as standard.

Anti-condensation

Anti-condensation heating can be provided for motors where there is a danger that moisture condensation will form on the winding due to the climatic situation. This anti-condensation heater warms up the air in the motor to a temperature above the dew point temperature in order to prevent condensation forming inside the motor. The anti-condensation heating must not be switched on while the motor is operational.

Graphic showing the temperature at which the moisture in the air will condensate to water. The lines on the left show the local temperature. The x-axis gives the local relative humidity. The "dew Point" temperature can be read on the Y-axis.

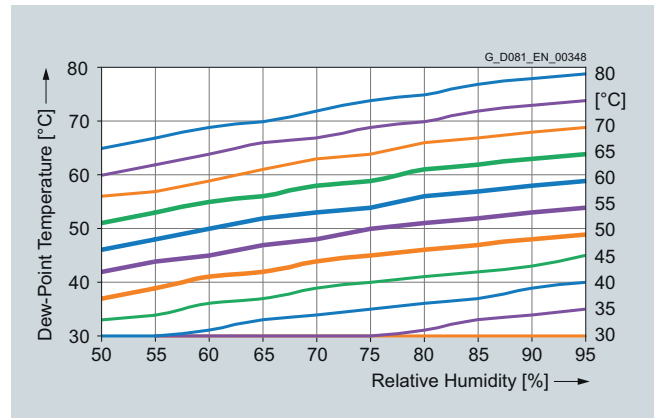

TIP

Another possible solution is to connect a voltage to the stator terminals U1 and V1 that should be between 4 and 10% of the rated motor voltage. Approximately 20 to 30% of the rated current is sufficient in order to achieve an adequate temperature rise to avoid condensation.

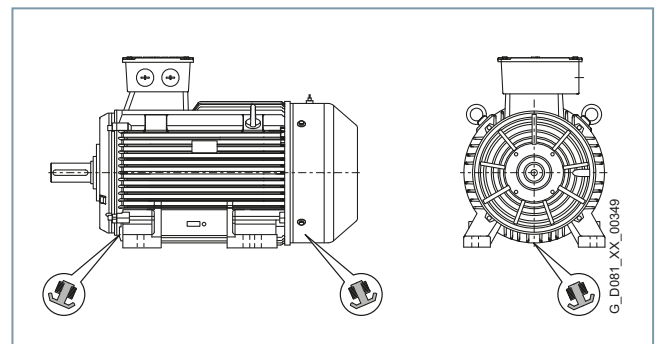

Drain hole location

Motor protection

PTC thermistor temperature sensors are predominantly used for thermistor motor protection devices (alarm or shutdown) for motors. These thermistors are generally integrated in the winding overhang. As a consequence, the stator winding is directly protected. The temperature difference between alarm and shutdown (trip) is 10 K.

When a limit temperature is reached (nominal tripping temperature), the resistance of PTC thermistors will have a step change. This is evaluated by a tripping unit and can be used to open auxiliary circuits.

Thermal protection with PTC thermistors with 3 embedded temperature sensors for tripping is provided in our IE2 motors above frame size 112 as standard version. Anyhow it can be selected as an option for our IE1 motors and IE2 motors with frame size less than 132. Connection can be done through 2 auxiliary terminals in the terminal box.

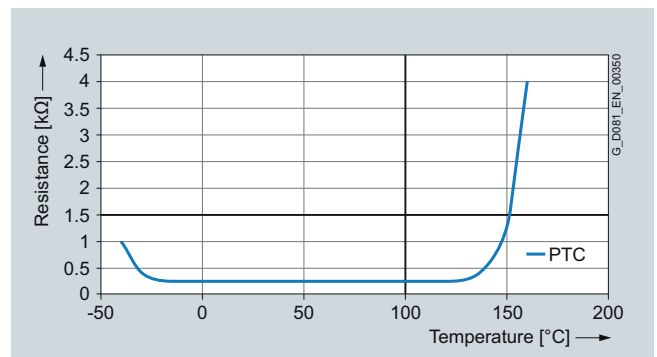

Note:

The PTC thermistors themselves cannot be subjected to high currents and voltages. This would result in destruction of the semiconductor. The switching hysteresis of the PTC thermistor and tripping unit is low, which supports fast restarting of the drive. Motors with this type of protection are recommended for heavy duty starting, switching duty, extreme changes in load, high ambient temperatures or fluctuating supply systems.

TIP

3 x PTC have already been embedded in our 1LE0 IE2 motors as standard version.

Converter-fed application

The insulation system of our motors is capable for converter-fed operation as standard.
 For sinusoidal (mains) supplies 690 V_{rms} 50 Hz with:
 phase to phase 1200 V_{rms} capability
 phase to ground 900 V_{rms} capability
 For converter-fed operation, as standard:
 460 V_{rms} max. Frequency limited by motor maximum speed 5000 V/μs

Converter-fed application

Our motors are suitable for pumps, fans, compressors, textile machine and mechanical machine applications where variable or constant speed is required. In applications where the motor is driven by a converter, the degree of electrical interference depends on the type of converter used (type, number of IGBTs, interference suppression measures, and manufacturer), cabling, distance and application requirements. The installation guidelines of the converter manufacturer with regards to electromagnetic compatibility must be considered at all times during the design and implementation phases.

At rated output with converter-fed operation, the motors will be used in temperature class 155 (F). To prevent damage as a result of bearing currents, insulated bearings are recommended to be assembled for frame size 250 and above. Please inquire Siemens about the detailed information of insulated bearing.

Converter-fed operation

The standard insulation of our motors is designed such that operation is possible on the converter at mains voltage up to 460 V.

Our motors are capable for converter-fed operation with certain characteristics load, of which the load torque characteristics is referred in the following diagram:

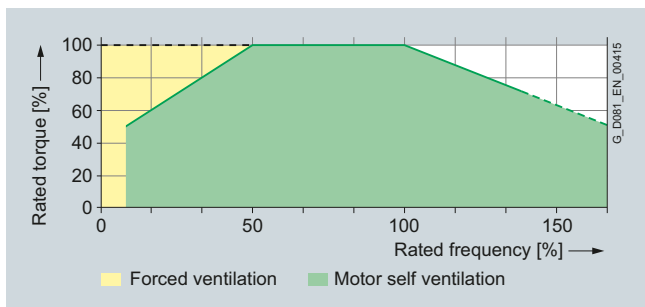

By usage with admissible torque and below, the motor can be operated with self cooling; by usage over the admissible torque line, the motor with forced ventilation is needed.

TIP

These motors do not have a special series for converter-fed operation – they are suited as standard. On-line or converter-fed operation.

At operating speeds above rated speed the noise and vibration levels increase and the bearing lifetime reduces. Attention should be paid to the re-greasing intervals and the grease service life. For converter-fed operation with frequencies greater than 60 Hz special balancing is required for compliance with the specified limit values.

Voltage (peak and gradient) withstand levels

The dielectric stress of the winding insulation is determined by:

- the peak voltage, rise time and frequency of the impulses produced by the converter.
- the characteristics and the length of the connection leads between the converter and motor.
- the winding construction and other system parameters, especially the voltages between the different parts of the winding and the ground represent dielectric stress at the insulation system.

The standard insulation of our motors is designed to withstand voltage peak and gradient which is showed in the diagram:

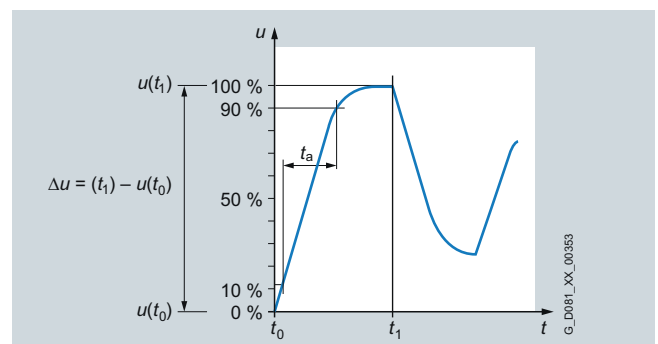
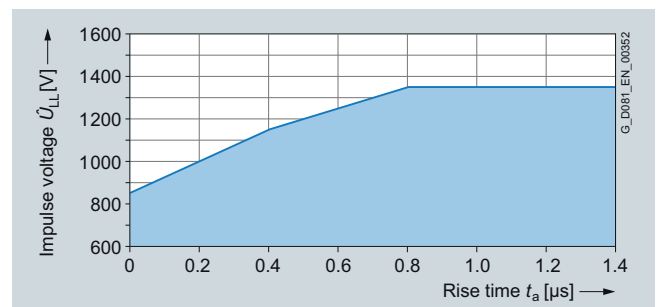

Did you know

As the motor gets larger so does the internal surface area between the stator and rotor. That surface has a stray capacitance which can lead to a voltage on the shaft – and that voltage can lead to bearing failure (bearing currents). The situation is aggravated by converter-fed operation. Siemens recommends the use of insulated bearings for motors of frame size ≥ 250 . The insulated bearing as an option can be supplied out of our standard catalog portfolio D 81.1 and on request for the 1LE0 series.

Converter-fed application

SIMOTICS General Purpose											
Frame size	Number of poles	Aluminum Series						Cast Iron Series			
		Efficiency IE1				Efficiency IE2		Efficiency IE1		Efficiency IE2	
		1LA7		1LE1002		1LE1001		1LE0102		1LE0101	
		max. mechanical speed	f_{max}	max. mechanical speed	f_{max}	max. mechanical speed	f_{max}	max. mechanical speed	f_{max}	max. mechanical speed	f_{max}
63	2	6000	100	-	-	-	-	-	-	-	-
	4	4200	140	-	-	-	-	-	-	-	-
	6	3600	180	-	-	-	-	-	-	-	-
71	2	6000	100	-	-	-	-	-	-	-	-
	4	4200	140	-	-	-	-	-	-	-	-
	6	3600	180	-	-	-	-	-	-	-	-
80	2	6000	100	-	-	6000	100	5200	87	5200	87
	4	4200	140	-	-	4200	140	3600	120	3600	120
	6	3600	180	-	-	3600	180	2400	120	2400	120
90	2	6000	100	-	-	6000	100	5200	87	5200	87
	4	4200	140	-	-	4200	140	3600	120	3600	120
	6	3600	180	-	-	3600	180	2400	120	2400	120
100	2	-	-	6000	100	6000	100	5200	87	5200	87
	4	-	-	4200	140	4200	140	3600	120	3600	120
	6	-	-	3600	180	3600	180	2400	120	2400	120
112	2	-	-	6000	100	6000	100	5200	87	5200	87
	4	-	-	4200	140	4200	140	3600	120	3600	120
	6	-	-	3600	180	3600	180	2400	120	2400	120
132	2	-	-	5600	93	5600	93	4500	75	4500	75
	4	-	-	4200	140	4200	140	2700	90	2700	90
	6	-	-	3600	180	3600	180	2400	120	2400	120
160	2	-	-	4800	80	4800	80	4500	75	4500	75
	4	-	-	4200	140	4200	140	2700	90	2700	90
	6	-	-	3600	180	3600	180	2400	120	2400	120
180	2	-	-	-	-	-	-	4500	75	4500	75
	4	-	-	-	-	-	-	2700	90	2700	90
	6	-	-	-	-	-	-	2400	120	2400	120
200	2	-	-	-	-	-	-	4500	75	4500	75
	4	-	-	-	-	-	-	2300	77	2300	77
	6	-	-	-	-	-	-	1800	90	1800	90
225	2	-	-	-	-	-	-	3600	60	3600	60
	4	-	-	-	-	-	-	2300	77	2300	77
	6	-	-	-	-	-	-	1800	90	1800	90
250	2	-	-	-	-	-	-	3600	60	3600	60
	4	-	-	-	-	-	-	2300	77	2300	77
	6	-	-	-	-	-	-	1800	90	1800	90
280	2	-	-	-	-	-	-	3600	60	3600	60
	4	-	-	-	-	-	-	2300	77	2300	77
	6	-	-	-	-	-	-	1800	90	1800	90
315	2	-	-	-	-	-	-	3600	60	3600	60
	4	-	-	-	-	-	-	2300	77	2300	77
	6	-	-	-	-	-	-	1800	90	1800	90
355	2	-	-	-	-	-	-	3600	60	3600	60
	4	-	-	-	-	-	-	2300	77	2300	77
	6	-	-	-	-	-	-	1800	90	1800	90

Mechanical stress and grease lifetime (converter-fed operation).

High speeds that exceed the rated speed and the resulting increased vibrations alter the mechanical running smoothness and the bearings are subject to increased mechanical stress. This reduces the grease lifetime and the bearing lifetime. More detailed information on request.

Ventilation/noise generation (converter-fed operation).

The fan noise can increase at speeds that are higher than the rated speed of self-ventilated motors. To increase motor utilization at low speeds it is recommended that forced ventilated motors are used.

Mechanical limit speeds

When the motor is operated at its rated frequency, it is important to note that the maximum speeds are limited by the limits for the roller bearings, critical rotor speed and rigidity of the rotating parts.

All the data listed in the brochure is applicable for a 50 Hz line supply. With converter-fed operation, the reduction factors for constant torque and drives for fans, pumps and compressors must be observed.



TIP 

By use of converter-fed operation, motors can run at speeds higher than 50 Hz or 60 Hz nominal speed. High speeds that exceed the rated speed of a motor can lead to increased vibration and substantially decrease the life expectancy of the bearings. The maximum mechanical speed of a motor must not be exceeded due to risk of failure. More detailed information on request.

Noise

Motors are often used in applications in which noise is a primary concern. The use of converters can excite the surfaces of motors and sound of diverse frequencies can be resonate in the cooling channels.

Siemens has addressed this issue but modifying the core design.

Surfaces, shapes and materials and air channels have been optimised. The result is a motor which is quieter, especially with converter-fed operation.

Output (kW)	Aluminum S				
	Efficiency IE1				
	3000 rpm (2-pole)	1LA7 1500 rpm (4-pole)	1000 rpm (6-pole)	3000 rpm (2-pole)	1LE1002 1500 rpm (4-pole)
0.09	-	-	39 / 50	-	-
0.12	-	42 / 53	-	-	-
0.18	49 / 60	42 / 53	39 / 50	-	-
0.25	49 / 60	44 / 55	39 / 50	-	-
0.37	52 / 63	44 / 55	40 / 51	-	-
0.55	52 / 63	47 / 58	40 / 51	-	-
0.75	56 / 67	47 / 58	43 / 55	-	-
1.1	56 / 67	48 / 60	43 / 55	-	-
1.5	60 / 74	48 / 60	-	-	-
2.2	60 / 74	-	-	-	60 / 72
3	-	-	-	67 / 79	60 / 72
4	-	-	-	69 / 81	58 / 70
5.5	-	-	-	68 / 80	64 / 76
7.5	-	-	-	68 / 80	64 / 76
11	-	-	-	70 / 82	65 / 77
15	-	-	-	70 / 82	65 / 77
18.5	-	-	-	70 / 82	-
22	-	-	-	-	-
30	-	-	-	-	-
37	-	-	-	-	-
45	-	-	-	-	-
55	-	-	-	-	-
75	-	-	-	-	-
90	-	-	-	-	-
110	-	-	-	-	-
132	-	-	-	-	-
160	-	-	-	-	-
185	-	-	-	-	-
200	-	-	-	-	-
220	-	-	-	-	-
250	-	-	-	-	-
280	-	-	-	-	-
315	-	-	-	-	-

SIMOTICS General Purpose										
L _{pfa} / L _{WA} (dB(A))										
Series				Cast Iron Series						
Series	Efficiency IE2 1LE1001			Efficiency IE1 1LE0102			Efficiency IE2 1LE0101			
	1000 rpm (6-pole)	3000 rpm (2-pole)	1500 rpm (4-pole)	1000 rpm (6-pole)	3000 rpm (2-pole)	1500 rpm (4-pole)	1000 rpm (6-pole)	3000 rpm (2-pole)	1500 rpm (4-pole)	1000 rpm (6-pole)
-	-	-	-	-	-	-	-	-	-	-
-	-	-	-	-	-	-	-	-	-	-
-	-	-	-	-	-	-	-	-	-	-
-	-	-	-	-	-	-	-	-	-	-
-	-	-	42 / 53	-	-	-	-	-	-	-
-	-	53 / 64	42 / 53	-	45 / 57	44 / 56	-	45 / 57	44 / 56	-
-	60 / 71	53 / 64	43 / 55	53 / 65	45 / 57	48 / 60	53 / 65	45 / 57	48 / 60	48 / 60
-	60 / 71	56 / 68	43 / 55	53 / 65	48 / 60	48 / 60	53 / 65	47 / 59	48 / 60	48 / 60
59 / 71	65 / 77	56 / 68	59 / 71	60 / 72	48 / 60	54 / 66	60 / 72	47 / 59	52 / 64	52 / 64
57 / 69	65 / 77	60 / 72	57 / 69	60 / 72	57 / 69	54 / 66	60 / 72	55 / 67	54 / 66	54 / 66
63 / 75	67 / 79	60 / 72	63 / 75	64 / 76	57 / 69	57 / 69	62 / 74	55 / 67	56 / 69	56 / 69
63 / 75	69 / 81	58 / 70	63 / 75	65 / 77	57 / 69	57 / 69	63 / 75	55 / 67	56 / 69	56 / 69
63 / 75	68 / 80	64 / 76	63 / 75	68 / 80	58 / 71	57 / 69	66 / 79	57 / 70	56 / 69	56 / 69
67 / 79	68 / 80	64 / 76	67 / 79	68 / 80	58 / 71	61 / 73	66 / 79	57 / 70	60 / 73	60 / 73
67 / 79	70 / 82	65 / 77	67 / 79	70 / 83	61 / 74	61 / 73	67 / 80	60 / 73	60 / 73	60 / 73
-	70 / 82	65 / 77	-	70 / 83	61 / 74	61 / 74	67 / 80	60 / 73	61 / 74	61 / 74
-	70 / 82	-	-	70 / 83	63 / 76	65 / 78	67 / 80	61 / 74	65 / 78	65 / 78
-	-	-	-	72 / 85	63 / 76	65 / 78	69 / 82	61 / 74	65 / 78	65 / 78
-	-	-	-	76 / 90	65 / 78	66 / 80	71 / 84	63 / 76	65 / 79	65 / 79
-	-	-	-	76 / 90	66 / 80	66 / 80	71 / 84	63 / 77	65 / 79	65 / 79
-	-	-	-	76 / 90	66 / 79	66 / 80	74 / 88	63 / 77	65 / 79	65 / 79
-	-	-	-	78 / 92	67 / 81	66 / 80	74 / 88	64 / 78	65 / 79	65 / 79
-	-	-	-	79 / 93	70 / 84	70 / 84	74 / 88	66 / 80	66 / 80	66 / 80
-	-	-	-	79 / 93	70 / 84	70 / 84	76 / 90	66 / 80	66 / 80	66 / 80
-	-	-	-	80 / 94	76 / 90	70 / 84	78 / 92	69 / 83	68 / 82	68 / 82
-	-	-	-	80 / 94	76 / 90	70 / 84	78 / 92	69 / 83	68 / 83	68 / 83
-	-	-	-	80 / 94	78 / 92	77 / 92	81 / 95	69 / 83	72 / 87	72 / 87
-	-	-	-	85 / 98	78 / 92	77 / 92	81 / 95	74 / 88	75 / 90	75 / 90
-	-	-	-	85 / 98	78 / 92	77 / 92	81 / 95	74 / 88	75 / 90	75 / 90
-	-	-	-	86 / 101	86 / 101	77 / 92	86 / 101	82 / 97	75 / 90	75 / 90
-	-	-	-	86 / 101	86 / 101	-	86 / 101	82 / 97	-	-
-	-	-	-	88 / 103	86 / 101	-	88 / 103	85 / 100	-	-
-	-	-	-	88 / 103	86 / 101	-	88 / 103	85 / 100	-	-

In order to define the motor noise level, the A-weighted sound pressure level (L_A) is measured at several points on the measuring plane (1 m away from the motor surface). The measurement is carried out in a room with low reflection. As a result of noise reflection, the level can be increased up to 3 dB(A) depending on the acoustic properties of the surroundings.

The A sound power level is normally used when engineering projects and when it is necessary to determine the noise radiated from a group of motors whose envelope dimensions differ significantly.

Bearing

The bearings are especially important in order that the motor runs perfectly. A good selection of bearing will guarantee long lubrication intervals, low noise, low-vibration operation and longer lifetime as well.

There are many types of bearing: diverse ball and cylinder bearings, taper and specialized bearings. Siemens has selected an applicable range of single and double shielded bearings. Z for when regreasing is needed and ZZ when no-regreasing is wished for.

A selection of C62 for speed and size and C63 for load carrying capacity associated with belt loads.

Sealed-for-life bearings are avoided as they bring inherent disadvantages in operation temperatures and limit operational speeds.

Special bearings are avoided due to their disadvantages outside of their specific application.

TIP

Factors that reduce the lifetime of a bearing:

- Operating a motor beyond the rated speed increases the motor vibration and results in an additional radial and axial force on the bearing.
- Increased motor vibration due to the environment or other equipment results in an higher radial and axial force.

The bearing lifetime of motors with horizontal type of construction is at least 40,000 hours if there is no additional axial loading at the coupling output and at least 20,000 hours with the maximum admissible loads. This assumes that the motor is operated at 50 Hz.

A bearing is only as good as its lubrication. Siemens designed a special lithium complex grease – Unirex N3. It gives a super thermal stability for optimized bearing life. The grease gives a great temperature range from -30 °C to 130 °C – with an intermittent temperature reserve to 165 °C.

Frame size	Number of poles	Grease lifetime up to CT 40 °C ¹⁾
Grease for permanent lubrication bearing		
80 ... 250	2, 4, 6	20000 or 40000 (h) ²⁾
Grease for regreasable bearing		
100 ... 160	2, 4, 6	8000 (h)
180 ... 250	2	4000 (h)
180 ... 250	4, 6	8000 (h)
280 ... 315	2	3000 (h)
280 ... 315	4, 6	5000 (h)
355	2	2000 (h)
355	4, 6	4000 (h)

¹⁾ If the coolant temperature is increased by 10 K, the grease lifetime and regreasing interval are halved.

²⁾ 40,000 h apply to horizontally installed motors with coupling output without additional axial loads.

Cantilever force

This force acts transversely at the centerline of the motor shaft extension. The cantilever force is calculated from the circumferential force multiplied by the pre-tension factor, which is dependent on the mechanical transmission characteristics of the particular belt.

The permissible cantilever forces for the individual motor frame sizes and speeds are specified in Catalog D 81.1. For motors with deep-groove ball bearings, the permissible cantilever force can be increased by replacing the bearings at the drive end with cylindrical roller bearings.

In order to calculate the admissible cantilever forces for a radial load, the line of force (i.e. the centerline of the pulley) of the cantilever force F_Q (N) must lie within the free shaft extension (dimension x).

Dimension x [mm] is the distance between the point of application of force F_Q and the shaft shoulder.

Dimension x_{max} corresponds to the length of the shaft extension. Total cantilever force is calculated using the following equation.

$$F_Q = c \cdot F_U$$

The pre-tension factor c is a value gained from experience from the belt manufacturer. The following approximate value can be assumed.

- For normal flat leather belts with an idler pulley, $c = 2$.
- For v-belts, $c = 2$ to 2.5 .
- For special synthetic belts (depending on the type and load), $c = 2$ to 2.5 .

The circumferential force F_U (N) is calculated using the following equation.

$$F_U = 2 \cdot 10^7 \frac{P}{n \times D}$$

F_U = circumferential force in N

P = rated motor power (transmitted power) in kW

n = rated motor speed

D = pulleys in mm.

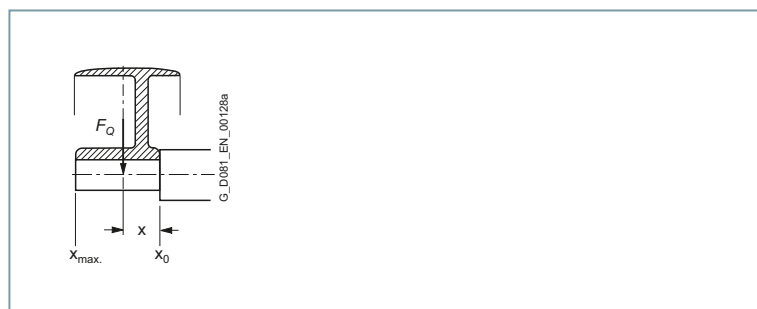

Belt drive

A belt drive is used to connect two parallel shafts, the motor shaft with the shaft of the driven machine, whereby the speed can be simultaneously changed corresponding to the ratio between the two belt pulley diameters.

The belt must be pre-tensioned so that it can transmit the circumferential force through friction. The pre-tension factor indicates how much higher the actual tension load (cantilever force) is than the circumferential force (peripheral force).

Today, flat belts are almost always manufactured out of plastic with an adhesive coating (e.g. chrome leather). Pre-tension factor, approx. 2 to 2.5.

The pre-tension factor for V-belts is approx. 1.5 to 2.5.

The belt must be able to transmit the power at the defined circumferential velocity. This defines the belt thickness and width. The belt supplier specifies the pre-tension factor. The recommended circumferential velocity is approx. 35 m/s for flat belts and approx. 25 m/s for V-belts. Steel belt pulleys must be used for circumferential velocities greater than 26 m/s due to the centrifugal force which occurs.

The actual cantilever force (belt tension) must be compared with the cantilever force permissible for the motor to select the correct motor and bearing sizes.

Bearing – Bearing types

Standard bearing assignment

SIMOTICS G								
Frame size	Number of poles	Aluminum Series						
		Efficiency IE1						
		1LA7	Efficiency IE1		1LE1002			
	Drive end	Non-drive end (Horizontal mounting)	Non-drive end (Vertical mounting)	Drive end	Non-drive end (Horizontal mounting)	Non-drive end (Vertical mounting)	Drive end	
63	2	6201 2Z C3	6201 2Z C3	6201 2Z C3	-	-	-	-
	4	6201 2Z C3	6201 2Z C3	6201 2Z C3	-	-	-	-
	6	6201 2Z C3	6201 2Z C3	6201 2Z C3	-	-	-	-
71	2	6202 2Z C3	6202 2Z C3	6202 2Z C3	-	-	-	-
	4	6202 2Z C3	6202 2Z C3	6202 2Z C3	-	-	-	-
	6	6202 2Z C3	6202 2Z C3	6202 2Z C3	-	-	-	-
80	2	6004 2Z C3	6004 2Z C3	6004 2Z C3	-	-	-	6004 2Z C3
	4	6004 2Z C3	6004 2Z C3	6004 2Z C3	-	-	-	6004 2Z C3
	6	6004 2Z C3	6004 2Z C3	6004 2Z C3	-	-	-	6004 2Z C3
90	2	6205 2Z C3	6004 2Z C3	6004 2Z C3	-	-	-	6205 2Z C3
	4	6205 2Z C3	6004 2Z C3	6004 2Z C3	-	-	-	6205 2Z C3
	6	6205 2Z C3	6004 2Z C3	6004 2Z C3	-	-	-	6205 2Z C3
100	2	-	-	-	6206 2Z C3	6206 2Z C3	6206 2Z C3	6206 2Z C3
	4	-	-	-	6206 2Z C3	6206 2Z C3	6206 2Z C3	6206 2Z C3
	6	-	-	-	6206 2Z C3	6206 2Z C3	6206 2Z C3	6206 2Z C3
112	2	-	-	-	6206 2Z C3	6206 2Z C3	6206 2Z C3	6206 2Z C3
	4	-	-	-	6206 2Z C3	6206 2Z C3	6206 2Z C3	6206 2Z C3
	6	-	-	-	6206 2Z C3	6206 2Z C3	6206 2Z C3	6206 2Z C3
132	2	-	-	-	6208 2Z C3	6208 2Z C3	6208 2Z C3	6208 2Z C3
	4	-	-	-	6208 2Z C3	6208 2Z C3	6208 2Z C3	6208 2Z C3
	6	-	-	-	6208 2Z C3	6208 2Z C3	6208 2Z C3	6208 2Z C3
160	2	-	-	-	6209 2Z C3	6209 2Z C3	6209 2Z C3	6209 2Z C3
	4	-	-	-	6209 2Z C3	6209 2Z C3	6209 2Z C3	6209 2Z C3
	6	-	-	-	6209 2Z C3	6209 2Z C3	6209 2Z C3	6209 2Z C3
180	2	-	-	-	-	-	-	-
	4	-	-	-	-	-	-	-
	6	-	-	-	-	-	-	-
200	2	-	-	-	-	-	-	-
	4	-	-	-	-	-	-	-
	6	-	-	-	-	-	-	-
225	2	-	-	-	-	-	-	-
	4	-	-	-	-	-	-	-
	6	-	-	-	-	-	-	-
250	2	-	-	-	-	-	-	-
	4	-	-	-	-	-	-	-
	6	-	-	-	-	-	-	-
280	2	-	-	-	-	-	-	-
	4	-	-	-	-	-	-	-
	6	-	-	-	-	-	-	-
315	2	-	-	-	-	-	-	-
	4	-	-	-	-	-	-	-
	6	-	-	-	-	-	-	-
355	2	-	-	-	-	-	-	-
	4	-	-	-	-	-	-	-
	6	-	-	-	-	-	-	-

Bearing – Bearing types

Bearing design for increased cantilever forces

SIMOTICS G								
Frame size	Number of poles	Aluminum Series						
		Efficiency IE1						
		Drive end	1LA7 Non-drive end (Horizontal mounting)	Non-drive end (Vertical mounting)	Drive end	1LE1002 Non-drive end (Horizontal mounting)	Non-drive end (Vertical mounting)	Drive end
63	2	-	-	-	-	-	-	-
	4	-	-	-	-	-	-	-
	6	-	-	-	-	-	-	-
71	2	-	-	-	-	-	-	-
	4	-	-	-	-	-	-	-
	6	-	-	-	-	-	-	-
80	2	-	-	-	-	-	-	-
	4	-	-	-	-	-	-	-
	6	-	-	-	-	-	-	-
90	2	-	-	-	-	-	-	-
	4	-	-	-	-	-	-	-
	6	-	-	-	-	-	-	-
100	2	-	-	-	6306 2Z C3	6206 2Z C3	6206 2Z C3	6306 2Z C3
	4	-	-	-	6306 2Z C3	6206 2Z C3	6206 2Z C3	6306 2Z C3
	6	-	-	-	6306 2Z C3	6206 2Z C3	6206 2Z C3	6306 2Z C3
112	2	-	-	-	6306 2Z C3	6206 2Z C3	6206 2Z C3	6306 2Z C3
	4	-	-	-	6306 2Z C3	6206 2Z C3	6206 2Z C3	6306 2Z C3
	6	-	-	-	6306 2Z C3	6206 2Z C3	6206 2Z C3	6306 2Z C3
132	2	-	-	-	6308 2Z C3	6208 2Z C3	6208 2Z C3	6308 2Z C3
	4	-	-	-	6308 2Z C3	6208 2Z C3	6208 2Z C3	6308 2Z C3
	6	-	-	-	6308 2Z C3	6208 2Z C3	6208 2Z C3	6308 2Z C3
160	2	-	-	-	6309 2Z C3	6209 2Z C3	6209 2Z C3	6309 2Z C3
	4	-	-	-	6309 2Z C3	6209 2Z C3	6209 2Z C3	6309 2Z C3
	6	-	-	-	6309 2Z C3	6209 2Z C3	6209 2Z C3	6309 2Z C3
180	2	-	-	-	-	-	-	-
	4	-	-	-	-	-	-	-
	6	-	-	-	-	-	-	-
200	2	-	-	-	-	-	-	-
	4	-	-	-	-	-	-	-
	6	-	-	-	-	-	-	-
225	2	-	-	-	-	-	-	-
	4	-	-	-	-	-	-	-
	6	-	-	-	-	-	-	-
250	2	-	-	-	-	-	-	-
	4	-	-	-	-	-	-	-
	6	-	-	-	-	-	-	-
280	2	-	-	-	-	-	-	-
	4	-	-	-	-	-	-	-
	6	-	-	-	-	-	-	-
315	2	-	-	-	-	-	-	-
	4	-	-	-	-	-	-	-
	6	-	-	-	-	-	-	-
355	2	-	-	-	-	-	-	-
	4	-	-	-	-	-	-	-
	6	-	-	-	-	-	-	-

Bearing – Cantilever forces

Admissible cantilever forces for standard version

SIMOTICS General Purpose											
Frame size	Number of poles	Aluminum Series						Cast Iron Series			
		Efficiency IE1		Efficiency IE2		Efficiency IE1		Efficiency IE2			
		1LA7	1LE1002	1LE1001	1LE0102	1LE0101	for x_0	for x_{max}	for x_0	for x_{max}	
		for x_0	for x_{max}	for x_0	for x_{max}	for x_0	for x_{max}	for x_0	for x_{max}	for x_0	for x_{max}
		N	N	N	N	N	N	N	N	N	N
63	2	270	240	-	-	-	-	-	-	-	-
	4	350	305	-	-	-	-	-	-	-	-
	6	415	360	-	-	-	-	-	-	-	-
71	2	415	355	-	-	-	-	-	-	-	-
	4	530	450	-	-	-	-	-	-	-	-
	6	630	535	-	-	-	-	-	-	-	-
80	2	485	400	-	-	485	400	620	510	620	510
	4	625	515	-	-	625	515	790	640	790	640
	6	735	605	-	-	735	605	910	740	910	740
90	2	725	605	-	-	725	605	700	560	700	560
	4	920	775	-	-	920	775	880	720	880	720
	6	1090	910	-	-	1090	910	1020	820	1020	820
100	2	-	-	1010	825	1010	825	980	790	980	790
	4	-	-	1230	1010	1230	1010	1230	990	1230	990
	6	-	-	1440	1180	1440	1180	1420	1140	1420	1140
112	2	-	-	970	785	970	785	980	790	980	790
	4	-	-	1235	1000	1235	1000	1230	990	1870	1540
	6	-	-	1440	1165	1440	1165	1420	1140	2140	1720
132	2	-	-	1470	1180	1470	1180	1440	1120	1440	1120
	4	-	-	1830	1470	1830	1470	1820	1420	2720	2170
	6	-	-	2150	1730	2150	1730	2080	1630	3100	2420
160	2	-	-	1550	1270	1550	1270	1560	1240	1560	1240
	4	-	-	1910	1550	1910	1550	1970	1570	3300	2600
	6	-	-	2230	1810	2230	1810	2260	1800	3750	2900
180	2	-	-	-	-	-	-	1820	1470	1820	1470
	4	-	-	-	-	-	-	2300	1900	4000	3300
	6	-	-	-	-	-	-	2630	2150	4500	3700
200	2	-	-	-	-	-	-	2650	2230	2650	2230
	4	-	-	-	-	-	-	3350	2800	5400	4530
	6	-	-	-	-	-	-	3850	3230	6200	5200
225	2	-	-	-	-	-	-	3000	2540	3000	2540
	4	-	-	-	-	-	-	3700	3000	5900	4800
	6	-	-	-	-	-	-	4250	3470	6800	5550
250	2	-	-	-	-	-	-	3150	2620	3150	2620
	4	-	-	-	-	-	-	3950	3280	7350	6100
	6	-	-	-	-	-	-	4600	3820	8450	7000
280	2	-	-	-	-	-	-	6600	5550	6600	5550
	4	-	-	-	-	-	-	8300	6950	8300	6950
	6	-	-	-	-	-	-	9650	8120	9650	8120
315	2	-	-	-	-	-	-	7100	6200	7100	6200
	4	-	-	-	-	-	-	8700	7250	8700	7250
	6	-	-	-	-	-	-	10000	8500	10000	8500
355	2	-	-	-	-	-	-	6800	6000	6800	6000
	4	-	-	-	-	-	-	11500	10000	11500	10000
	6	-	-	-	-	-	-	13200	11600	13200	11600

Bearing design for increased cantilever forces

SIMOTICS General Purpose											
Frame size	Number of poles	Aluminum Series						Cast Iron Series			
		Efficiency IE1		Efficiency IE2		Efficiency IE1		Efficiency IE2			
		1LA7	1LE1002	1LE1001	1LE1002	1LE1001	1LE1010	1LE1011			
		for x_0	for x_{max}	for x_0	for x_{max}	for x_0	for x_{max}	for x_0	for x_{max}	for x_0	for x_{max}
		N	N	N	N	N	N	N	N	N	N
63	2	-	-	-	-	-	-	-	-	-	-
	4	-	-	-	-	-	-	-	-	-	-
	6	-	-	-	-	-	-	-	-	-	-
71	2	-	-	-	-	-	-	-	-	-	-
	4	-	-	-	-	-	-	-	-	-	-
	6	-	-	-	-	-	-	-	-	-	-
80	2	-	-	-	-	-	-	-	-	-	-
	4	-	-	-	-	-	-	-	-	-	-
	6	-	-	-	-	-	-	-	-	-	-
90	2	-	-	-	-	-	-	-	-	-	-
	4	-	-	-	-	-	-	-	-	-	-
	6	-	-	-	-	-	-	-	-	-	-
100	2	-	-	1585	1300	1585	1300	1480	1220	1480	1220
	4	-	-	1960	1610	1960	1610	1870	1540	1870	1540
	6	-	-	2270	1865	2270	1865	2140	1720	2140	1720
112	2	-	-	1545	1250	1545	1250	1480	1220	1480	1220
	4	-	-	1960	1585	1960	1585	1870	1540	-	-
	6	-	-	2270	1835	2270	1835	2140	1720	-	-
132	2	-	-	2285	1840	2285	1840	2100	1700	2100	1700
	4	-	-	2860	2300	2860	2300	2720	2170	-	-
	6	-	-	3320	2670	3320	2670	3100	2420	-	-
160	2	-	-	2800	2240	2800	2240	2650	2120	2650	2120
	4	-	-	3450	2270	3450	2270	3300	2600	-	-
	6	-	-	4000	3200	4000	3200	3750	2900	-	-
180	2	-	-	-	-	-	-	3300	2700	3300	2700
	4	-	-	-	-	-	-	4200	3400	4200	3400
	6	-	-	-	-	-	-	4750	3900	4750	3900
200	2	-	-	-	-	-	-	5000	4200	5000	4200
	4	-	-	-	-	-	-	6330	5320	6330	5320
	6	-	-	-	-	-	-	7250	6080	7250	6080
225	2	-	-	-	-	-	-	5650	4800	5650	4800
	4	-	-	-	-	-	-	6950	5600	6950	5600
	6	-	-	-	-	-	-	7900	6500	7900	6500
250	2	-	-	-	-	-	-	6700	5600	6700	5600
	4	-	-	-	-	-	-	8500	7000	8500	7000
	6	-	-	-	-	-	-	9500	7800	9500	7800
280	2	-	-	-	-	-	-	11500	9500	11500	9500
	4	-	-	-	-	-	-	17000	14000	17000	14000
	6	-	-	-	-	-	-	20000	17000	20000	17000
315	2	-	-	-	-	-	-	14600	12300	14600	12300
	4	-	-	-	-	-	-	20000	16500	20000	16500
	6	-	-	-	-	-	-	23000	19000	23000	19000
355	2	-	-	-	-	-	-	15800	14000	15800	14000
	4	-	-	-	-	-	-	22000	19000	22000	19000
	6	-	-	-	-	-	-	25000	22000	25000	22000

Terminal box

TIP

The terminal box is located on the top of the motor housing as standard, and can be rotated by 4 x 90° – on some 1LE1 even 360° – to allow for cable entry from each direction.

All terminal boxes have two cable entries sealed by a screwed plug.

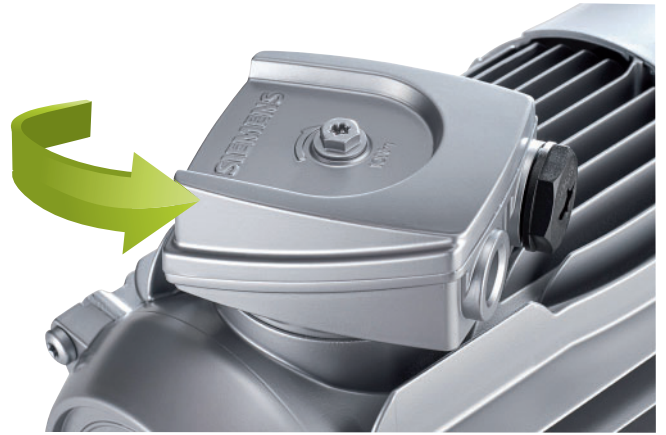

1LA7

Frame size	Aluminum Series				
	Efficiency IE1				
	1LA7				
Number of terminals	Contact screw thread	Max. connectable cross-section (mm ²)	Outer cable diameter (sealing range)	Cable entry size (screwed plug)	
63	6	M4	1.5	9 ... 17	1xM25x1.5 + 1xM16x1.5
71	6	M4	1.5	9 ... 17	1xM25x1.5 + 1xM16x1.5
80	6	M4	1.5	9 ... 17	1xM25x1.5 + 1xM16x1.5
90	6	M4	1.5	9 ... 17	1xM25x1.5 + 1xM16x1.5



1LE10

Frame size	Aluminum Series									
	Efficiency IE1					Efficiency IE2				
	1LE1002					1LE1001				
Number of terminals	Contact screw thread	Max. connectable cross-section (mm ²)	Outer cable diameter (sealing range)	Cable entry size (screwed plug)	Number of terminals	Contact screw thread	Max. connectable cross-section (mm ²)	Outer cable diameter (sealing range)	Cable entry size (screwed plug)	
80	–	–	–	–	–	6	M3.5	1.5	9 ... 17	1xM25x1.5 + 1xM16x1.5
90	–	–	–	–	–	6	M3.5	1.5	9 ... 17	1xM25x1.5 + 1xM16x1.5
100	6	M4	4	11 ... 21	2xM32x1.5	6	M4	4	11 ... 21	2xM32x1.5
112	6	M4	4	11 ... 21	2xM32x1.5	6	M4	4	11 ... 21	2xM32x1.5
132	6	M4	6	11 ... 21	2xM32x1.5	6	M4	6	11 ... 21	2xM32x1.5
160	6	M5	16	19 ... 28	2xM40x1.5	6	M5	16	19 ... 28	2xM40x1.5

Motors with an aluminum housing are particularly user friendly. The terminal box introduced for frame sizes 100 to 160 has proven its worth and is consistently implemented throughout the motor series for 2- and 4-pole motors of frame sizes 80 and 90.

The terminal box is only fixed with one screw and can be rotated steplessly by up to 360°. The terminal box is also preconfigured with a terminal board. This makes installation quicker and easier in confined spaces as the motor connection cables can be fed in from any direction.

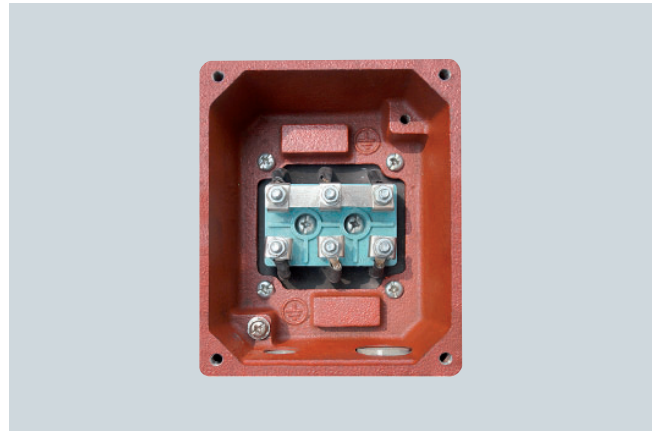

1LE0

Frame size	Cast Iron Series									
	Efficiency IE1					Efficiency IE2				
	Number of terminals	Contact screw thread	1LE0102			1LE0101			Number of terminals	Contact screw thread
Max. connectable cross-section (mm ²)			Outer cable diameter (sealing range)	Cable entry size (screwed plug)	Max. connectable cross-section (mm ²)	Outer cable diameter (sealing range)	Cable entry size (screwed plug)			
80	6	M4	1.5	13 ... 18	M25 x 1.5 + M16 x 1.5	6	M4	1.5	13 ... 18	M25 x 1.5 + M16 x 1.5
90	6	M4	1.5	13 ... 18	M25 x 1.5 + M16 x 1.5	6	M4	1.5	13 ... 18	M25 x 1.5 + M16 x 1.5
100	6	M4	4	18 ... 25	M32 x 1.5 + M32 x 1.5	6	M4	4	18 ... 25	M32 x 1.5 + M32 x 1.5
112	6	M4	4	18 ... 25	M32 x 1.5 + M32 x 1.5	6	M4	4	18 ... 25	M32 x 1.5 + M32 x 1.5
132	6	M4	6	18 ... 25	M32 x 1.5 + M32 x 1.5	6	M4	6	18 ... 25	M32 x 1.5 + M32 x 1.5
160	6	M5	16	22 ... 32	M40 x 1.5 + M40 x 1.5	6	M5	16	22 ... 32	M40 x 1.5 + M40 x 1.5
180	6	M5	16	22 ... 32	M40 x 1.5 + M40 x 1.5	6	M5	16	22 ... 32	M40 x 1.5 + M40 x 1.5
200	6	M6	25	32 ... 38	M50 x 1.5 + M50 x 1.5	6	M6	25	32 ... 38	M50 x 1.5 + M50 x 1.5
225	6	M8	35	32 ... 38	M50 x 1.5 + M50 x 1.5	6	M8	35	32 ... 38	M50 x 1.5 + M50 x 1.5
250	6	M10	120	37 ... 44	M63 x 1.5 + M63 x 1.5	6	M10	120	37 ... 44	M63 x 1.5 + M63 x 1.5
280	6	M10	120	37 ... 44	M63 x 1.5 + M63 x 1.5	6	M10	120	37 ... 44	M63 x 1.5 + M63 x 1.5
315	6	M12	240	37 ... 44	M63 x 1.5 + M63 x 1.5	6	M12	240	37 ... 44	M63 x 1.5 + M63 x 1.5
355	6	M20	240	44 ... 57	M72 x 2 + M72 x 2	6	M20	240	44 ... 57	M72 x 2 + M72 x 2

4 SIMOTICS General Purpose Low-Voltage Motors 1LE0 option line

The **1LE0 option line** is a new set of motors offering extended options and voltages based on the 1LE0 motor family. This broadens the 1LE0 portfolio to fulfill a wider range of requirements for motor specifications in different environments and applications. **The article number of the 1LE0 option line (1LE002) is different to the 1LE0 distribution line (1LE010).** The basic motor of the 1LE0 option line is a standard motor without any included features. A wide range of options can be added into the configuration as needed. As a highlight, options like PTC, condensation drain hole and bearing for increased cantilever force are included as standard in the 1LE0 distribution line only.

Additional options of the 1LE0 option line are designed to suit the different requirements of the customer. They also enhance the distribution portfolio to project specifications and specific OEM machines.

1LE0 option line for general industrial applications

Frame size	80 to 355
Power range	0.55 kW to 315 kW (referred to 1,500 rpm rated speed)
Number of poles	2, 4 and 6 poles
Motor material	Frame and terminal box: Cast iron
Article number and Efficiency class	1LE0022: IE1 Improved efficiency 1LE0021: IE2 High efficiency
Voltages	230 V to 690 V, selectable according list of voltage codes
Insulation system	Direct-on-line operation upto 690 V, Converter-fed upto 460 V + tolerance
Temperature class	155 (F) utilization to 130 (B)
Ambient temperature	Standard – 20 °C to + 40 °C , optional – 40 °C to + 40 °C
Construction type	Standard IMB3 and other types of construction as option
Degree of protection	IP55, optional IP56
Winding protection	Optional PTC, PT100 and KTY84-130
Modular concept	Encoder and separated driven fan as option



LL 861 900 220 encoder, Option G04

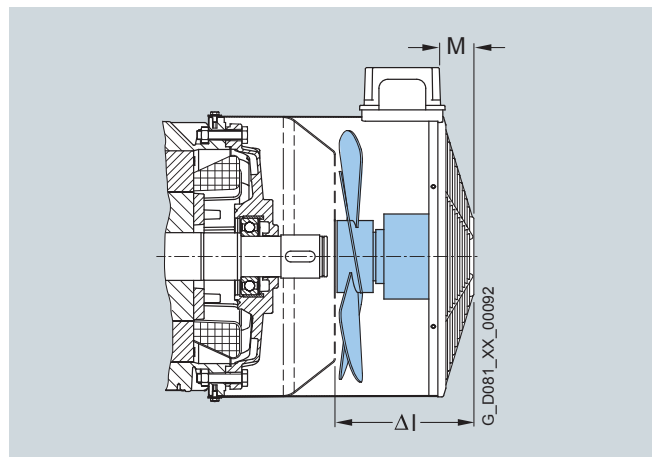

Separately driven fan, Option F70

Product highlights

1. Wide range of options – can be selected according to specific customer requirements. The basic 1LE0 option line motor is a standard motor without any built-in features.

2. Fulfill voltage and construction requirements – The motor line offers additional selection of rated voltages and mounting types.

3. Easy retrofit and upgrade – due to harmonized design dimensions throughout the whole 1LE0 motor family.

4. Common user and spare parts – are applicable within the 1LE0 motor line.

5. Increase plant and system availability – Options of winding protection, insulated bearing and separately driven fan enhance the availability and thus reliability of the system.

6. Global support – worldwide warranty and service

Application note

- **Pump:** Energy saving for quadratic torque load with variable speed operation
- **Fan:** Ideal for flow control application
- **Material handling:** Effectively working with continuous and intermittent periodic duties. Reliable operation.



Pump

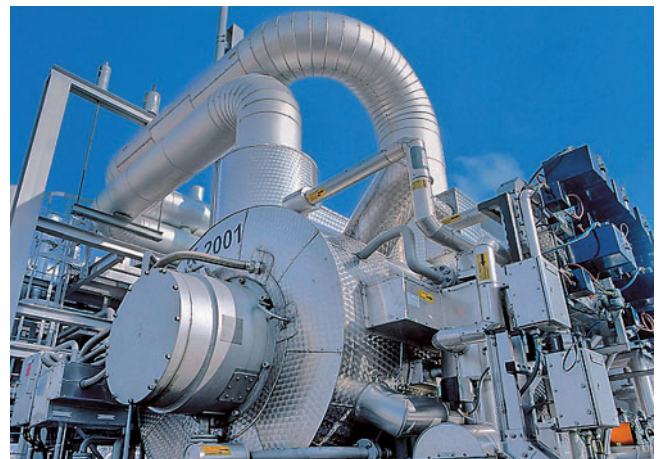

Fan



Material handling

Flexible control options

With separately driven fan, the motor can be worked with inverter in constant torque operation. This is the result of continuous full speed ventilation of forced fan option.

Working with SINAMICS, you can rely on a drive family with flexible control options – with V/f control as well as vector control. As a result, applications can be addressed with basic speed control and with higher speed precision with encoderless vector control or with encoder.

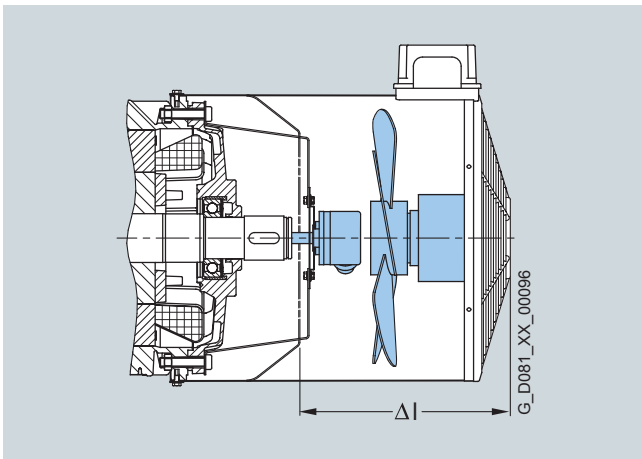
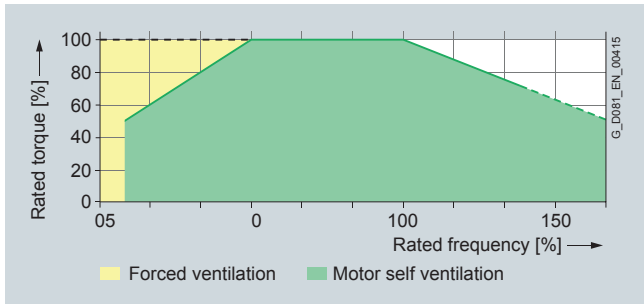

Motor with encoder and separated driven fan

Highlight features

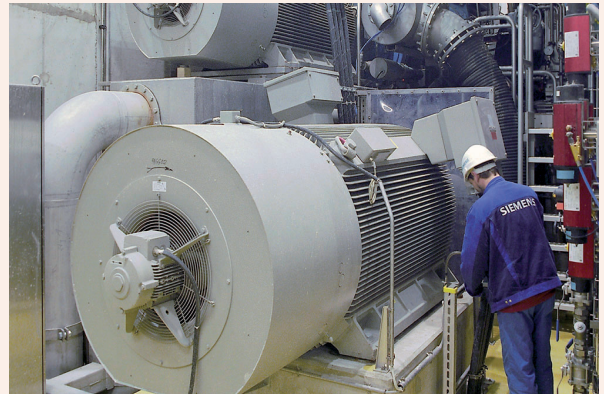

Highlight motor options

- Insulated bearing, encoder and separately driven fan to increase reliability for converter-fed operation
- KTY84-130 and PT100 sensors are additional protections that can evaluate motor temperature for alarm and tripping.
- Measuring nipple for SPM shock pulse measurement for bearing inspection
- Vibration severity level B according to IEC 60034-14
- Rotation of terminal box on right or left hand side of the motor drive end
- Additional degree of protection IP56

Article number explanation

Structure of Article No. (1LE0 option line)

Structure	Position: 1 2 3 4 5 6 7 - 8 9 10 11 12 - 13 14 15 16 - Z
<u>Position 1 to 6:</u>	Low-voltage motor series • 1LE0 option line
<u>Position 7:</u>	Motor efficiency • Motor with high efficiency - IE2 • Motor with improved efficiency - IE1
<u>Position 8 to 11:</u>	Frame size, number of poles and frame length Refer to page 14
<u>Position 12 and 13:</u>	Voltage, circuit and frequency • 22 = 230 VD/400 VY 50 Hz • 34 = 400 VD/690 VY 50 Hz • 35 = 415 VD 50 Hz • 21 = 220 VD/380 VY 50 Hz • 33 = 380 VD/660 VY 50 Hz • 90 = special voltage & frequency • 23 = 240 VD/415 VY 50 Hz • 41 = 525 VD 50 Hz
<u>Position 14:</u>	Type of construction (refer to page 17) • A = IM B3 • J = IM B35 • F = IM B5 • G = IM V1 • K = IM B14 • T = IM B6 • U = IM B7 • V = IM B8 • C = IM V5 • D = IM V6 • N = IM B34 • M = IM V18 • L = IM V19 • W = IM V15 • Y = IM V35 • G = IM V1 • H = IM V3
<u>Position 15:</u>	Motor protection • A = without winding protection • B = 3 PTC thermistors for tripping • C = 6 PTC thermistors for alarm and tripping • F = 1 temperature sensor KTY 84-130 • H = 3 resistance thermometers Pt100 • J = 6 resistance thermometers Pt100
<u>Position 16:</u>	Terminal box location (view from drive end) • 4 = on top • 5 = on RHS • 6 = on LHS
	Special order version Coded - Order (option) code also required

Ordering example

1LE0021 – 1DB43 – 4AH4-Z, F70+B02

1LE0 option line motor, IE2 high efficiency motor, FS160, 4 poles, 400 VD/690 VY 50 Hz, IM B3, 3 resistance thermometers PT100, terminal box on top **included separated driven fan (F70) and Acceptance test certificate 3.1 in accordance with EN 10204 (B02).**

List of options

Remark: The basic 1LE0 extended option motor does not include any option as standard.

Motor frame size	Position of article No. 12 th & 13 th	Option code ¹⁾	Description
Voltage and frequency			
FS80 ~ 132	21		220 VD / 380 VY 50 Hz ²⁾
FS100 ~ 355	33		380 VD / 660 VY 50 Hz ²⁾
FS80 ~ 132	22		230 VD / 400 VY 50 Hz ²⁾
FS100 ~ 355	34		400 VD / 690 VY 50 Hz ²⁾
FS80 ~ 355	23		240 VD / 415 VY 50 Hz
FS80 ~ 355	35		415 VD 50 Hz
FS80 ~ 355	41		525 VD 50 Hz
FS80 ~ 355	90	M2A	220 VD / 380 VY 60 Hz (50 Hz output)
FS80 ~ 355	90	M2B	380 VD 60 Hz (50 Hz output)
FS80 ~ 355	90	M2C	440 VY 60 Hz (50 Hz output)
FS80 ~ 355	90	M2D	440 VD 60 Hz (50 Hz output)
FS80 ~ 355	90	M2E	460 VY 60 Hz (50 Hz output)
FS80 ~ 355	90	M2F	460 VD 60 Hz (50 Hz output)
Motor frame size	Position of article No. 15 th	Option code ¹⁾	Description
Motor protection			
FS80 ~ 355	A ²⁾		Without motor protection
FS80 ~ 355	B		Motor protection with PTC thermistors with three embedded temperature sensors for tripping
FS80 ~ 355	C		Motor protection with PTC thermistors with 6 embedded temperature sensors for alarm and tripping
FS100 ~ 355	F		Motor temperature detection with embedded temperature sensor KTY 84-130
FS80 ~ 355	H		Installation of three PT100 resistance thermometers
FS80 ~ 355	J		Installation of six PT100 resistance thermometers
Motor frame size	Position of article No. 16 th	Option code ¹⁾	Description
Motor terminal box			
FS80 ~ 355	4		Terminal box top
FS80 ~ 355	5		Terminal box on RHS
FS80 ~ 355	6		Terminal box on LHS
FS80 ~ 355		R10 ³⁾	Rotation of the terminal box through 90°, entry from DE
FS80 ~ 355		R11	Rotation of the terminal box through 90°, entry from NDE
FS80 ~ 355		R12	Rotation of the terminal box through 180°
FS80 ~ 355		H08 ⁴⁾	Terminal box on NDE
Winding and Insulation			
FS80 ~ 355		N01	Temperature class 155 (F), used acc. to 155 (F), with service factor (SF)
FS80 ~ 355		N10	Temperature class 180 (H)
FS80 ~ 355		Q04	Anti-condensation heating for 220 V
FS80 ~ 355		Q02	Anti-condensation heating for 230 V

TIP



In the basic bearing system, the located bearing is at the NDE or the bearing at the NDE is fixed. And the bearing at the DE is free or “floating”. Therefore it allows thermal (axial) growth of the shaft. In case of pump application with vertical mounting, the axial and trust load have to be considered and L20 option, located bearing at DE, is recommended.

Motor frame size	Option code ¹⁾	Description
Bearing		
FS100 ~ 355	L22	Bearing design for increased cantilever forces
FS80 ~ 160	L20	Located bearing DE
FS100 ~ 250	L23 ⁵⁾	Regreasing device
FS180 ~ 355	Q72	Installation of 2 PT100 screw-in resistance thermometers for bearings
FS250 ~ 355	L53 ⁶⁾	Insulated bearing
FS100 ~ 355	Q01	Measuring nipple for SPM shock pulse measurement for bearing inspection
Balance and vibration quantity		
FS80 ~ 355	L00	Vibration quantity level B
Mechanical design and degree of protection		
FS80 ~ 355	L05 ⁷⁾⁸⁾	Second standard shaft extension, NDE
FS80 ~ 355	H00 ⁹⁾	Protective cover (canopy)
FS80 ~ 355	H03 ¹⁰⁾	Condensation drainage holes
FS80 ~ 280	H04 ¹¹⁾	External earthing
FS80 ~ 355	H22	IP56 degree of protection (non-heavy-sea)
Modular technology		
FS80 ~ 355	F70 ¹²⁾	Mounting of separately driven fan
FS80 ~ 355	F90 ¹³⁾	Without external fan and without fan cover
FS80 ~ 355	F76	Metal fan
FS112 ~ 355	G04	Mounting of LL 861 900 220 rotary pulse encoder
Rating plate and test certificates		
FS80 ~ 355	B02	Acceptance test certificate 3.1 according to EN 10204
Paint finish		
FS80 ~ 355	S01	Unpainted, only primed
Coolant temperature		
FS80 ~ 355	D03	Coolant temperature -40 to +40 °C

1) Article No. supplement Z with option code when ordering.

2) Without additional charge.

3) For FS80 to 112 motor, R10 only in combination with option code H08 (Terminal box on NDE) possible.

4) Cable entry on terminal box towards the non-drive end.

5) FS280, FS315 and FS355 motor with the regreasing device as standard.

6) For horizontal mounting motor, the insulated bearing is located at NDE. For vertical mounting motor, the insulated bearing is located at DE.

7) Not possible in combination with canopy or separately driven fan (order code: F70).

8) Second standard shaft extension on NDE is smaller than DE and provides output at the level of the next smaller frame size.

9) Only applicable for the construction type IM V5, IM V1, IM V15 and IM V18. Not possible in combination with option code L05.

10) Position of the condensation drainage hole will be adapted to the construction type of the motor accordingly.

11) FS315 and FS355 motor with external earthing as standard.

12) When the separately driven fan is mounted, the length of the motor increases by ΔL.

13) Without fan and fan cover, the length of the motor decreases by ΔL. By using the power output of rating plate, the motor must have external cooling by air flow. The correct motor cooling is in responsibility of customer. Missing or wrong cooling reduces the life time or damages the motor.



Dimensional drawings

IM B3

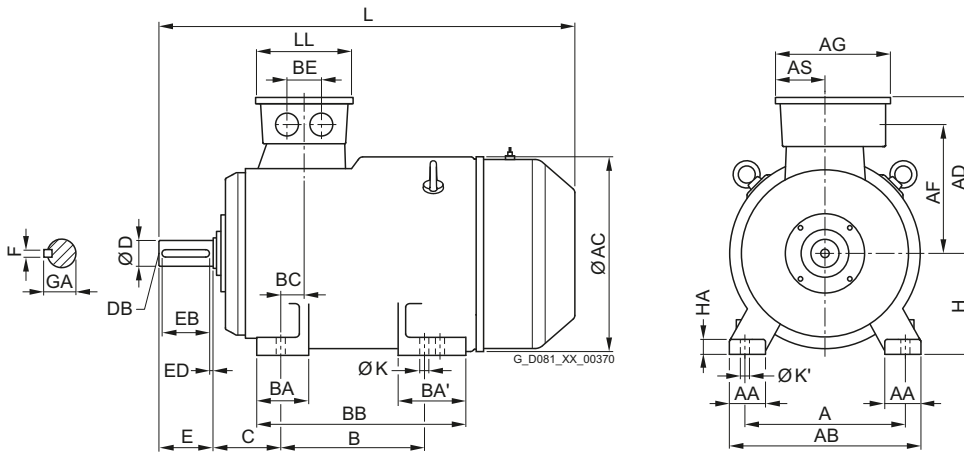

IM B35

For flange dimensions, see Page 58 (Z = the number of retaining holes)

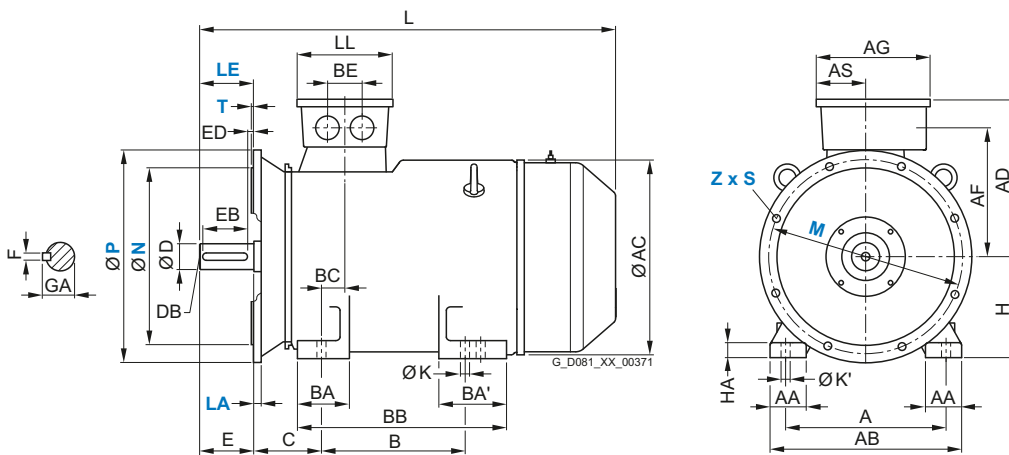

IM B5 and IM V1

For flange dimensions, see Page 58 (Z = the number of retaining holes)

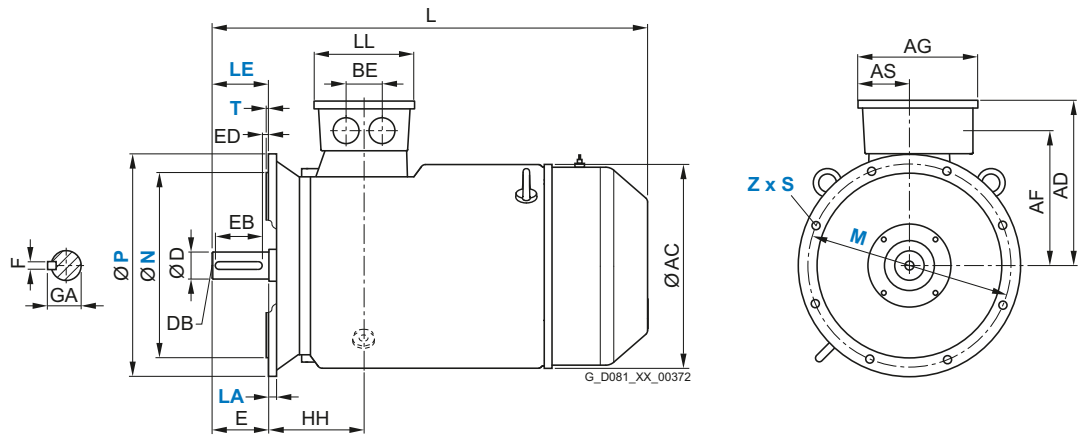

IM B14

For flange dimensions, see Page 58 (Z = the number of retaining holes)

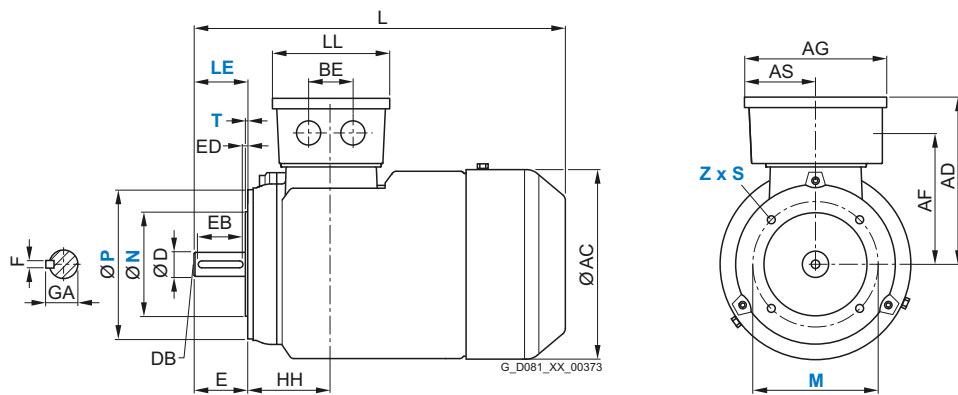

Aluminum series – 1LA7

For motor			Dimension designation acc. to IEC																				
Frame size	Type	Number of poles	A	AA	AB	AC ¹⁾	AD ²⁾	AD'	AF ²⁾	AF'	AG ²⁾	AS	B*	BA	BA'	BB	BC	BE ²⁾	BE' ²⁾	C	CA*	H	HA
63 M	1LA7060 1LA7063	2, 4, 6	100	27	120	124	101	101	78	78	75	37.5	80	28	–	96	30	32	18	40	66	63	7
71 M	1LA7070 1LA7073	2, 4, 6	112	27	132	145	111	111	88	88	75	37.5	90	27	–	106	18	32	18	45	83	71	7
80 M	1LA7080 1LA7083	2, 4, 6 2, 4, 6	125	30.5	150	163	120	120	97	97	75	37.5	100	32	–	118	14	32	18	50	94	80	8
90 S	1LA7090	2, 4, 6	140	30.5	165	180	128	128	105	105	75	37.5	100	33	54	143	23	32	18	56	143	90	10
90 L	1LA7096	2, 4, 6											125							118			
100 L	1LA7106 1LA7107	2, 4, 6 2	160	42	196	203	135	163	78	123	120	60	140	47	–	176	39	42	21	63	125	100	12
																					195 ³⁾		

* This dimension is assigned in DIN EN 50347 to the frame size listed.

1) Measured across the bolt heads.

2) The values increase if the terminal box is rotated or if a brake is mounted.

Further information is provided by the dimension sheet generator in the DT Configurator.

3) Only for 1LA7107-4PM.

Aluminum series – 1LE10

For motor		Dimension designation acc. to IEC																					
Frame size	Number of poles	A	AA	AB	AC	AD	AD'	AF	AF'	AG	AS	B*	BA	BA'	BB	BC	BE	BE'	C ¹⁾	CA*	H	HA	Y ¹⁾
80 M	2, 4, 6	125	30.5	150	159	121	–	96.5	–	93	43	100	32	–	118	23	–	18 ²⁾	50	–	80	8	41
90 S	2, 4, 6	140	30.5	165	178	126	–	101.5	–	93	43	100	33	–	143	22.5	–	18 ²⁾	56	–	90	10	47
90 L	2, 4, 6	140	30.5	165	178	126	–	101.5	–	93	43	125	33	–	143	22.5	–	18 ²⁾	56	–	90	10	47
100 L	2, 4, 6	160	42	196	198	166	166	125.5	125.5	135	63.5	140	37.5	–	176	33.5	50	25	63	141	100	12	45
112 M	2, 4, 6	190	46	226	222	177	177	136.5	136.5	135	63.5	140	35.4	–	176	26	50	25	70	129.7	112	12	52
132 S	2, 4, 6	216	53	256	262	202	202	159.5	159.5	155	70.5	140	38	76 ³⁾	218 ⁴⁾	26.5	48	24	89	128.5 ⁵⁾	132	15	69
132 M	2, 4, 6	216	53	256	262	202	202	159.5	159.5	155	70.5	178	38	76	218	26.5	48	24	89	128.5 ⁵⁾	132	15	69
160 M	2, 4, 6	254	60	300	314	236.5	236.5	190	190	175	77.5	210	44	89 ⁶⁾	300 ⁷⁾	47	57	28.5	108	148 ⁸⁾	160	18	85
160 L	2, 4, 6	254	60	300	314	236.5	236.5	190	190	175	77.5	254	44	89	300	47	57	28.5	108	148 ⁸⁾	160	18	85

* This dimension is assigned in DIN EN 50347 to the frame size listed.

1) Additional information – not a standard dimension according to DIN EN 50347.

2) Connecting hole for terminal box is on the side at the rear of the terminal box.

3) With screwed-on feet, dimension BA' is 38 mm.

4) With screwed-on feet, dimension BB is 180 mm.

5) With screwed-on feet, dimension CA is 166.5 mm.

6) With screwed-on feet, dimension BA' is 44 mm.

7) With screwed-on feet, dimension BB is 256 mm.

8) With screwed-on feet, dimension CA is 192 mm.

9) The length is specified as far as the tip of the fan cover.

Aluminum series – 1LA7

For motor			Dimension designation acc. to IEC								DE shaft extension						
Frame size	Type	Number of poles	HH	K	K'	L	LC	LL	LM	D	DB	E	EB	ED	F	GA	
63 M	1LA7060	2, 4, 6	69.5	7	10	202.5 ¹⁾	232 ¹⁾	75	231.5 ¹⁾	11	M4	23	16	3.5	4	12.5	
	1LA7063																
71 M	1LA7070	2, 4, 6	63.5	7	10	240	278	75	268	14	M5	30	22	4	5	16	
	1LA7073																
80 M	1LA7080	2, 4, 6	63.5	9.5	13.5	273.5	324	75	299.5	19	M6	40	32	4	6	21.5	
	1LA7083																
90 S	1LA7090	2, 4, 6	79	10	14	331	389	75	382.5	24	M8	50	40	5	8	27	
90 L	1LA7096	2, 4, 6															
100 L	1LA7106	2, 4, 6	102	12	16	372	438	120	423.5	28	M10	60	50	5	8	31	
	1LA7107																2

Aluminum series – 1LE10

For motor		Dimension designation acc. to IEC									DE shaft extension						
Frame size	Number of poles	HH	K	K'	L	L1	D1	LC	LL	LM	D	DB	E	EB	ED	F	GA
80 M	2, 4, 6	73	9.5	13.5	292	–	–	–	79	–	19	M6	40	32	4	6	21.5
90 S	2, 4, 6	78.5	10	14	347	–	–	–	79	–	24	M8	50	40	5	8	27
90 L	2, 4, 6	78.5	10	14	347	–	–	–	79	–	24	M8	50	40	5	8	27
100 L	2, 4, 6	96.5	12	16	395.5 ⁹⁾	7	32	454	112	428.5	28	M10	60	50	5	8	31
112 M	2, 4, 6	96	12	16	389 ⁹⁾	7	32	450	112	422	28	M10	60	50	5	8	31
132 S	2, 4, 6	115.5	12	16	465 ⁹⁾	8.5	39	535.5	130	516.5	38	M12	80	70	5	10	41
132 M	2, 4, 6	115.5	12	16	465 ⁹⁾	8.5	39	535.5	130	516.5	38	M12	80	70	5	10	41
160 M	2, 4, 6	155	15	19	604 ⁹⁾	10	45	730	145	654	42	M16	110	90	10	12	45
160 L	2, 4, 6	155	15	19	604 ⁹⁾	10	45	730	145	654	42	M16	110	90	10	12	45

Cast Iron series – 1LE0

For motor			Dimension designation acc. to IEC																
Frame size	Motor type 1LE0-	Number of poles	A	AA	AB	AC ¹⁾	AD/AD'	AF/AF'	AG	AS	B ²⁾	BA/BA'	BB	BC	BE	C	CA*	H	HA
80 M	0D.2	2	125	36	160	157	142	110.5	161	65.5	100	44	135	26	42	50	103	80	10
	0D.2	4, 6	125	36	160	157	142	110.5	161	65.5	100	44	135	26	42	50	103	80	10
	0D.3	2, 4, 6	125	36	160	157	142	110.5	161	65.5	100	44	135	26	42	50	103	80	10
90 S	0E.0	2, 4, 6	140	46	175	175	152	120.5	161	65.5	100	46	140	20	42	56	115	90	10
90 L	0E.4		140	46	175	175	152	120.5	161	65.5	125	46	165	20	42	56	115	90	10
100 L	1A.4	2, 4, 6	160	45	200	196	177	140	175	70	140	45	176	30.5	54	63	133	100	12
	1A.5	4	160	45	200	196	177	140	175	70	140	45	176	30.5	54	63	133	100	12
112 M	1B.2	2, 4, 6	190	45	226	221	188.5	152	175	70	140	50	180	22	54	70	129.5	112	12
132 S	1C.0	2, 4, 6	216	50	256	259	191.5	175	175	70	140	64	186	32.5	54	89	178	132	15
	1C.1	2	216	50	256	259	191.5	175	175	70	140	64	186	32.5	54	89	178	132	15
132 M	1C.2	4, 6	216	50	256	259	191.5	175	175	70	178	64	224	32.5	54	89	185	132	15
	1C.3	6	216	50	256	259	191.5	175	175	70	178	64	224	32.5	54	89	185	132	15
160 M	1D.2	2, 4, 6	254	60	314	312	255	206	231	94	210	70	258	51	68	108	194	160	20
	1D.3	2	254	60	314	312	255	206	231	94	210	70	258	51	68	108	194	160	20
160 L	1D.4	2, 4, 6	254	60	314	312	255	206	231	94	254	70	302	51	68	108	210	160	20
180M	1E.2	2, 4	279	65	339	356	270	221	231	94	241	80	301	37	68	121	219	180	20
180L	1E.4	4, 6	279	65	339	356	270	221	231	94	279	80	339	37	68	121	216	180	20
200L	2A.4	2, 6	318	70	378	397	300	247.5	288	107.5	305	80	369	69	85	133	234	200	25
	2A.5	2, 4, 6	318	70	378	397	300	247.5	288	107.5	305	80	369	69	85	133	234	200	25
225S	2B.0	4	356	80	436	442	327	274	288	107.5	286	80	348	63	85	149	255	225	34
225M	2B.2	2	356	80	436	442	327	274	288	107.5	311	80	373	63	85	149	255	225	34
		4, 6																	
250M	2C.2	2	406	90	490	488	373	310.5	342	123	349	100	421	92	84	169	269	250	40
		4, 6																	
280S	2D.0	2	457	100	540	538	413	350.5	342	123	368	115	454	72	84	190	237	280	40
		4, 6																	
280M	2D.2	2	457	100	540	538	413	350.5	342	123	419	115	505	72	84	190	288	280	40
		4, 6																	
315S	3A.0	2	508	120	610	608	482	401	401	148	406	165	520	75	110	216	351	315	50
		4, 6																	
315M	3A.2	2	508	120	610	608	482	401	401	148	457/508	165	668	75	110	216	480	315	50
		4, 6																	
315L	3A.5/3A.6/ 3A.7	2	508	120	610	608	482	401	401	148	457/508	165	668	75	110	216	480	315	50
		4																	
355M	3B.2/3B.3	2	610	116	726	718	655	572	472	198.5	560/630	–	750	–	130	254	536	355	52
		4, 6																	
355L	3B.4	2	610	116	726	718	655	572	472	198.5	560/630	–	750	–	130	254	536	355	52
		6																	
355L	3B.5/3B.6	2	610	116	726	718	655	572	472	198.5	560/630	–	750	–	130	254	536	355	52
		4, 6																	

1) Measured across the bolt heads.

2) This dimension is assigned in DIN EN 50347 to the frame size listed.

For motor Frame size	Motor type 1LE0-	Number of poles	Dimension designation acc. to IEC					DE shaft extension							
			HH	K/K'	L	LC	LL	D	DB	E	EB	ED	F	GA	
80 M	OD.2	2	76	10	288	323	109	19	M6	40	32	3.5	6	21.5	
	OD.2	4, 6	76	10	288	323	109	19	M6	40	32	3.5	6	21.5	
	OD.3	2, 4, 6	76	10	288	323	109	19	M6	40	32	3.5	6	21.5	
90 S	OE.0	2, 4, 6	76	10	316	361	109	24	M8	50	40	3.5	8	27	
90 L	OE.4		76	10	341	386	109	24	M8	50	40	3.5	8	27	
100 L	1A.4	2, 4, 6	93.5	12	390	446	118	28	M10	60	50	3.5	8	31	
	1A.5	4	93.5	12	390	446	118	28	M10	60	50	3.5	8	31	
112 M	1B.2	2, 4, 6	92	12	393.5	449.5	118	28	M10	60	50	3.5	8	31	
132 S	1C.0	2, 4, 6	121.5	12	480	547	118	38	M12	80	70	4	10	41	
	1C.1	2	121.5	12	480	547	118	38	M12	80	70	4	10	41	
132 M	1C.2	4, 6	121.5	12	525	592	118	38	M12	80	70	4	10	41	
	1C.3	6	121.5	12	525	592	118	38	M12	80	70	4	10	41	
160 M	1D.2	2, 4, 6	159	15	614	701	158	42	M16	110	100	5	12	45	
	1D.3	2	159	15	614	701	158	42	M16	110	100	5	12	45	
160 L	1D.4	2, 4, 6	159	15	674	761	158	42	M16	110	100	5	12	45	
180M	1E.2	2, 4	158	15	683	801	158	48	M16	110	100	5	14	51.5	
180L	1E.4	4, 6	158	15	718	836	158	48	M16	110	100	5	14	51.5	
200L	2A.4	2, 6	202	19	772	892	215	55	M20	110	100	5	16	59	
	2A.5	2, 4, 6	202	19	772	892	215	55	M20	110	100	5	16	59	
225S	2B.0	4	212	19	820	940	215	60	M20	140	125	5	18	64	
225M	2B.2	2	212	19	815	935	215	55	M20	110	100	5	16	59	
		4, 6			845	965							60	140	125
250M	2C.2	2	260	24	917	1037	246	60	M20	140	125	5	18	64	
		4, 6											1067	65	69
280S	2D.0	2	262	24	976	1126	246	65	M20	140	125	5	18	69	
		4, 6											75	5	20
280M	2D.2	2	262	24	1027	1177	246	65	M20	140	125	5	18	69	
		4, 6											75	20	79.5
315S	3A.0	2	291	28	1113	1265	296	65	M20	140	125	6	18	69	
		4, 6			1143	1295							80	170	140
315M	3A.2	2	291	28	1293	1445	296	65	M20	140	125	6	18	69	
		4, 6			1323	1475							80	170	22
315L	3A.5/3A.6/ 3A.7	2	291	28	1293	1445	296	65	M20	140	125	6	18	69	
		4			1323	1475							80	170	140
	3A.5/3A.6	6	291	28	1323	1475	296	80	M20	170	140	6	22	85	
355M	3B.2/3B.3	2	298	28	1490	1652	397	75	M20	140	125	6	20	79.5	
		4, 6			1520	1712							95	M24	170
	3B.4	6	298	28	1520	1712	397	95	M24	170	140	6	25	100	
355L	3B.5/3B.6	2	298	28	1490	1652	397	75	M20	140	125	6	20	79.5	
		4, 6			1520	1712							95	M24	170

Flange dimensions

Type of construction – IM B5

Type of construction – IM B14

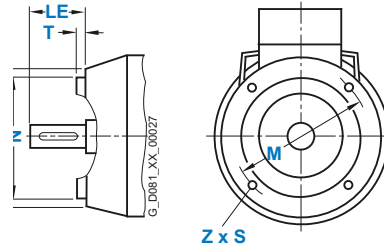
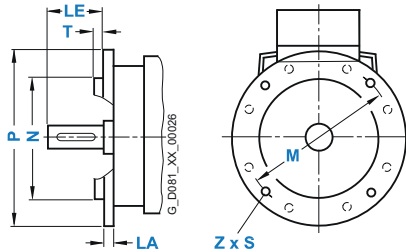

In DIN EN 50347, the frame sizes are allocated flange FF with through holes and flange FT with tapped holes. The designation of flange A and C according to DIN 42948 (invalid since September 2003) are also listed for information purposes. See the table below. (Z = the number of retaining holes).

Frame size	Type of construction	Flange type	Flange with		Dimension designation acc. to IEC							
			through holes (FF/A)	tapped holes (FT/C)	LA	LE	M	N	P	S	T	Z
			acc. to DIN EN 50347	acc. to DIN 42948								
Aluminum series – 1LA7												
63 M	IM B5, IM B35, IM V1, IM V3	Flange	FF 115	A 140	8	23	115	95	140	10	3	4
	IM B14, IM B34, IM V18, IM V19	Standard flange	FT 75	C 90	–	23	75	60	90	M5	2.5	4
	IM B14, IM B34, IM V18, IM V19	Special flange	FT 100	C 120	–	23	100	80	120	M6	3	4
71 M	IM B5, IM B35, IM V1, IM V3	Flange	FF 130	A 160	9	30	130	110	160	10	3.5	4
	IM B14, IM B34, IM V18, IM V19	Standard flange	FT 85	C 105	–	30	85	70	105	M6	2.5	4
	IM B14, IM B34, IM V18, IM V19	Special flange	FT 115	C 140	–	30	115	95	140	M8	3	4
80 M	IM B5, IM B35, IM V1, IM V3	Flange	FF 165	A 200	10	40	165	130	200	12	3.5	4
	IM B14, IM B34, IM V18, IM V19	Standard flange	FT 100	C 120	–	40	100	80	120	M6	3	4
	IM B14, IM B34, IM V18, IM V19	Special flange	FT 130	C 160	–	40	130	110	160	M8	3.5	4
90 S, 90 L	IM B5, IM B35, IM V1, IM V3	Flange	FF 165	A 200	10	50	165	130	200	12	3.5	4
	IM B14, IM B34, IM V18, IM V19	Standard flange	FT 115	C 140	–	50	115	95	140	M8	3	4
	IM B14, IM B34, IM V18, IM V19	Special flange	FT 130	C 160	–	50	130	110	160	M8	3.5	4
100 L	IM B5, IM B35, IM V1, IM V3	Flange	FF 215	A 250	11	60	215	180	250	14.5	4	4
	IM B14, IM B34, IM V18, IM V19	Standard flange	FT 130	C 160	–	60	130	110	160	M8	3.5	4
	IM B14, IM B34, IM V18, IM V19	Special flange	FT 165	C 200	–	60	165	130	200	M10	3.5	4

Frame size	Type of construction	Flange type	Flange with		Dimension designation acc. to IEC							
			through holes (FF/A)	tapped holes (FT/C)	LA	LE	M	N	P	S	T	Z
			acc. to DIN EN 50347	acc. to DIN 42948								
Aluminum series – 1LE10												
80 M	IM B5, IM B35, IM V1, IM V3	Flange	FF 165	A 200	10	40	165	130	200	12	3.5	4
	IM B14, IM B34, IM V18, IM V19	Standard flange	FT 100	C 120	–	40	100	80	120	M6	3	4
90 S, 90 L	IM B5, IM B35, IM V1, IM V3	Flange	FF 165	A 200	10	50	165	130	200	12	3.5	4
	IM B14, IM B34, IM V18, IM V19	Standard flange	FT 115	C 140	–	50	115	95	140	M8	3	4
100 L	IM B5, IM B35, IM V1, IM V3	Flange	FF 215	A 250	11	60	215	180	250	14.5	4	4
	IM B14, IM B34, IM V18, IM V19	Standard flange	FT 130	C 160	–	60	130	110	160	M8	3.5	4
	IM B14, IM B34, IM V18, IM V19	Special flange (next larger standard flange)	FT 165	C 200	–	60	165	130	200	M10	3.5	4
112 M	IM B5, IM B35, IM V1, IM V3	Flange	FF 215	A 250	11	60	215	180	250	14.5	4	4
	IM B14, IM B34, IM V18, IM V19	Standard flange	FT 130	C 160	–	60	130	110	160	M8	3.5	4
	IM B14, IM B34, IM V18, IM V19	Special flange (next larger standard flange)	FT 165	C 200	–	60	165	130	200	M10	3.5	4
132 S, 132 M	IM B5, IM B35, IM V1, IM V3	Flange	FF 265	A 300	12	80	265	230	300	14.5	4	4
	IM B14, IM B34, IM V18, IM V19	Standard flange	FT 165	C 200	–	80	165	130	200	M10	3.5	4
	IM B14, IM B34, IM V18, IM V19	Special flange (next larger standard flange)	FT 215	C 250	–	80	215	180	250	M12	4	4
160 M, 160 L	IM B5, IM B35, IM V1, IM V3	Flange	FF 300	A 350	13	110	300	250	350	18.5	5	4
	IM B14, IM B34, IM V18, IM V19	Standard flange	FT 215	C 250	–	110	215	180	250	M12	4	4
Cast Iron series – 1LE0												
80	IM B5, IM B35, IMV1, IM V3	Flange	FF 165	A 200	10	40	165	130	200	12	3.5	4
	IM B14, IM V18, IM V19	Standard flange	FT 100	C 120	-	40	100	80	120	M 6	3	4
90	IM B5, IM B35, IMV1, IM V3	Flange	FF 165	A 200	10	50	165	130	200	12	3.5	4
	IM B14, IM V18, IM V19	Standard flange	FT 115	C 140	-	50	115	95	140	M 8	3	4
100	IM B5, IM B35, IMV1, IM V3	Flange	FF 215	A 250	11	60	215	180	250	14.5	4	4
	IM B14, IM V18, IM V19	Standard flange	FT 130	C 160	-	60	130	110	160	M 8	3.5	4
112	IM B5, IM B35, IMV1, IM V3	Flange	FF 215	A 250	11	60	215	180	250	14.5	4	4
	IM B14, IM V18, IM V19	Standard flange	FT 130	C 160	-	60	130	110	160	M 8	3.5	4
132	IM B5, IM B35, IMV1, IM V3	Flange	FF 265	A 300	12	80	265	230	300	14.5	4	4
	IM B14, IM V18, IM V19	Standard flange	FT 165	C 200	-	80	165	130	200	M 10	3.5	4
160	IM B5, IM B35, IMV1, IM V3	Flange	FF 300	A 350	13	110	300	250	350	18.5	5	4
	IM B14, IM V18, IM V19	Standard flange	FT 215	C 250	-	110	215	180	250	M 12	4	4
180	IM B5, IM B35, IMV1, IM V3	Flange	FF 300	A 350	15	110	300	250	350	18.5	5	4
200	IM B5, IM B35, IMV1, IM V3	Flange	FF 350	A 400	17	110	350	300	400	18.5	5	4
225	IM B5, IM B35, IMV1, IM V3	Flange	FF 400	A 450	20	110/140	400	350	450	18.5	5	8
250	IM B5, IM B35, IMV1, IM V3	Flange	FF 500	A 550	22	140	500	450	550	18.5	5	8
280	IM B5, IM B35, IMV1, IM V3	Flange	FF 500	A 550	22	140	500	450	550	18.5	5	8
315	IM B5, IM B35, IMV1, IM V3	Flange	FF 600	A 660	22	140/170	600	550	660	24	6	8
355	IM B5, IM B35, IMV1, IM V3	Flange	FF 740	A 800	22	140/170	740	680	800	24	6	8

6

User parts

User parts selection 1LE0

Please note that an ordered quantity "1" will result in a package delivery containing pieces defined in column "Pieces per ordered package".

E.g. ordering "1" user parts package LMH:101358876 you will receive ten endshields drive-end B3.

IE class	User parts	Order quantity	Pieces per ordered package	User parts package Article No.
Frame size 80				
	Endshield drive-end B3	1	10	LMH:101358876
	Flange drive-end B5	1	10	LMH:101358877
	Flange drive-end B14	1	10	LMH:101358878
	"V"-RING-M20	1	30	LMH:101358879
	Fan	1	10	LMH:101358880
	Fan cover	1	9	LMH:101359001
	Canopy	1	6	LMH:101359002
	Terminal board	1	5	LMH:101359003
Frame size 90				
	Endshield drive-end B3	1	12	LMH:101359004
	Flange drive-end B5	1	10	LMH:101359005
	Flange drive-end B14	1	12	LMH:101359006
	"V"-RING-M25	1	30	LMH:101359007
	Fan	1	10	LMH:101359008
	Fan cover	1	9	LMH:101359009
	Canopy	1	6	LMH:101359010
	Terminal board	1	5	LMH:101359003
Frame size 100				
	Endshield drive-end B3	1	12	LMH:101359012
	Flange drive-end B5	1	12	LMH:101359013
	Flange drive-end B14	1	10	LMH:101359014
	"V"-RING-M30	1	30	LMH:101359015
	Fan	1	10	LMH:101359016
	Fan cover	1	9	LMH:101359017
	Canopy	1	6	LMH:101359018
	Terminal board	1	5	LMH:101359019
IE2	Fan	1	10	LMH:101359020
Frame size 112				
	Endshield drive-end B3	1	14	LMH:101359021
	Flange drive-end B5	1	12	LMH:101359022
	Flange drive-end B14	1	12	LMH:101359023
	"V"-RING-M30	1	30	LMH:101359015
	Fan	1	10	LMH:101359016
	Fan cover	1	9	LMH:101359026
	Canopy	1	6	LMH:101359027
	Terminal board	1	5	LMH:101359019
IE2	Endshield drive-end B3	1	14	LMH:101359029
IE2	Flange drive-end B5	1	12	LMH:101359030
IE2	Flange drive-end B14	1	12	LMH:101359031
Frame size 132				
	Endshield drive-end B3	1	4	LMH:101359032
	Flange drive-end B5	1	4	LMH:101359033
	Flange drive-end B14	1	4	LMH:101359034
	"V"-RING-M40	1	30	LMH:101359035
	Fan	1	10	LMH:101359036
	Fan cover	1	9	LMH:101359037
	Canopy	1	6	LMH:101359038
	Terminal board	1	5	LMH:101359019
IE2	Endshield drive-end B3	1	4	LMH:101359040
IE2	Flange drive-end B5	1	4	LMH:101359041
IE2	Flange drive-end B14	1	4	LMH:101359042
IE2	Fan	1	10	LMH:101359043

TIP

The parts required for simple modifications of the flange type or replacing parts broken during bearing change are readily available. The retrofitting of an encoder is a common modification. In order to make it easier, we offer the 1LE0 series with a non-drive end shaft mounting facility and the metal fan cover which has been prepared for modification.

IE class	User parts	Order quantity	Pieces per ordered package	User parts package Article No.
Frame size 160				
	Endshield drive-end B3	1	5	LMH:101359044
	Flange drive-end B5	1	5	LMH:101359045
	Flange drive-end B14	1	5	LMH:101359046
	Shaft seal	1	30	LMH:101359047
	Fan - 4-6-pole	1	10	LMH:101359048
	Fan - 2-pole	1	10	LMH:101359049
	Fan cover	1	9	LMH:101359050
	Canopy	1	6	LMH:101359051
	Terminal board	1	5	LMH:101359052
IE2	Endshield drive-end B3	1	5	LMH:101359053
IE2	Flange drive-end B5	1	5	LMH:101359054
IE2	Flange drive-end B14	1	5	LMH:101359055
IE2	Fan - 2-pole	1	10	LMH:101359056
Frame size 180				
	Endshield drive-end B3	1	5	LMH:101359057
	Flange drive-end B5	1	5	LMH:101359058
	Shaft seal	1	20	LMH:101359059
	Fan - 2-pole	1	5	LMH:101359067
IE1	Fan - 4-6-pole	1	5	LMH:101359061
	Fan cover	1	6	LMH:101359062
	Canopy	1	4	LMH:101359063
	Terminal board	1	5	LMH:101359052
IE2	Endshield drive-end B3	1	5	LMH:101359065
IE2	Flange drive-end B5	1	5	LMH:101359066
IE2	Fan	1	5	LMH:101359060
Frame size 200				
	Endshield drive-end B3	1	5	LMH:101359068
	Flange drive-end B5	1	5	LMH:101359069
	Shaft seal	1	20	LMH:101359070
	Fan - 4-6-pole	1	5	LMH:101359071
	Fan - 2-pole	1	5	LMH:101359072
	Fan cover	1	6	LMH:101359073
	Canopy	1	4	LMH:101359074
	Terminal board	1	3	LMH:101359075
IE2	Endshield drive-end B3	1	5	LMH:101359076
IE2	Flange drive-end B5	1	5	LMH:101359077
IE2	Fan - 2-pole	1	5	LMH:101359078
Frame size 225				
	Endshield drive-end B3	1	3	LMH:101359079
	Flange drive-end B5	1	3	LMH:101359080
	Shaft seal	1	20	LMH:101359081
	Fan - 2-pole	1	5	LMH:101359089
	Fan - 4-6-pole	1	5	LMH:101359083
	Fan cover	1	6	LMH:101359084
	Canopy	1	4	LMH:101359085
	Terminal board	1	3	LMH:101359086
IE2	Endshield drive-end B3	1	3	LMH:101359087
IE2	Flange drive-end B5	1	3	LMH:101359088
IE2	Fan - 4-6-pole	1	5	LMH:101359090

User parts selection 1LE0

Please note that an ordered quantity "1" will result in a package delivery containing pieces defined in column "Pieces per ordered package".

IE class	User parts	Order quantity	Pieces per ordered package	User parts package Article No.
Frame size 250				
	Endshield drive-end B3	1	3	LMH:101359091
	Flange drive-end B5	1	3	LMH:101359092
	Shaft seal	1	20	LMH:101359093
	Fan - 2-pole	1	5	LMH:101359094
	Fan - 4-6-pole	1	5	LMH:101359095
	Fan cover	1	6	LMH:101359096
	Canopy	1	4	LMH:101359097
	Terminal board	1	3	LMH:101359098
IE2	Endshield drive-end B3	1	3	LMH:101359099
IE2	Flange drive-end B5	1	3	LMH:101359100
IE2	Fan - 2-pole	1	5	LMH:101359078
Frame size 280				
	Shaft seal	1	20	LMH:101359102
	Endshield drive-end B3	1	3	LMH:101359103
	Flange drive-end B5	1	3	LMH:101359104
	Fan - 2-pole	1	5	LMH:101359095
	Fan - 4-6-pole	1	5	LMH:101359106
	Fan cover	1	6	LMH:101359107
	Canopy	1	4	LMH:101359108
	Terminal board	1	3	LMH:101359098
IE2	Fan - 2-pole	1	5	LMH:101359110

TIP

The parts required for simple modifications of the flange type or replacing parts broken during bearing change are readily available. The retrofitting of an encoder is a common modification. In order to make it easier, we offer the 1LE0 series with a non-drive end shaft mounting facility and the metal fan cover which has been prepared for modification.

IE class	User parts	Order quantity	Pieces per ordered package	User parts package Article No.
Frame size 315				
	Endshield drive-end B3	1	5	LMH:101359111
	Flange drive-end B5	1	3	LMH:101359112
	Shaft seal	1	10	LMH:101359113
	Fan - 2-pole FS 315L	1	3	LMH:101359114
	Fan - 2-pole FS 315 S/M	1	3	LMH:101359115
	Fan - 4-6-pole FS 315L	1	3	LMH:101359116
	Fan - 4-6-pole FS 315 S/M	1	3	LMH:101359117
IE1	Fan - 4-6-pole FS 315 L	1	3	LMH:101359118
	Fan cover	1	4	LMH:101359119
	Canopy	1	4	LMH:101359120
	Terminal board	1	2	LMH:101359121
IE2	Fan - 2-pole FS 315 S/M	1	3	LMH:101359122
IE2	Fan - 4-pole FS 315 S/M	1	3	LMH:101359123
Frame size 355				
	Endshield drive-end B3 2-pole	1	4	LMH:101359124
	Endshield drive-end B3 4-6-pole	1	4	LMH:101359125
	Shaft seal 4-6-pole	1	10	LMH:101359126
	Shaft seal 2-pole	1	10	LMH:101359113
	Fan - 2-pole	1	3	LMH:101359115
	Fan - 4-6-pole	1	3	LMH:101359117
	Fan cover	1	4	LMH:101359130
	Canopy	1	4	LMH:101359131
	Terminal board	1	2	LMH:101359132

Note:

The Siemens warranty is valid for all motors which are originally supplied from the Siemens factory. Any modification will result in the nameplate no longer describing the physical build. Any such local adaptation is at the discretion of the user and the quality and func-

tionality is a result of his work. We strongly recommend an additional nameplate to be fixed to the cowl describing those changes referencing the responsible workshop. That workshop carries the warranty for the motor and the associated modification.

User parts selection 1LA7/1LE1

User parts	Minimum order quantity	Motor series	Article No.
Frame size 63			
Shaft sealing ring	1	1LA7	–
Endshield drive-end B3	1	1LA7	XZM:21517134001001
Flange drive-end B5	1	1LA7	XZM:21517135501001
Flange drive-end B14 (small)	1	1LA7	XZM:21517136501001
Flange drive-end B14 (large)	1	1LA7	XZM:21517137501001
Fan cover ¹⁾	1	1LA7	XZM:20747017001000
Impeller - fan plastic	1	1LA7	XZM:20000000300320
Impeller - fan aluminum	1	1LA7	XZM:27000914510050
Terminal board	1	1LA7	XZM:27000910420550
Fan cover with canopy	1	1LA7	XZM:27000809820150
Frame size 71			
Shaft sealing ring	1	1LA7	–
Endshield drive-end B3	1	1LA7	XZM:27000915120450
Flange drive-end B5	1	1LA7	XZM:27000915122450
Flange drive-end B14 (small)	1	1LA7	XZM:27000915124650
Flange drive-end B14 (large)	1	1LA7	XZM:21517036501001
Fan cover ¹⁾	1	1LA7	XZM:27000807421850
Impeller - fan plastic	1	1LA7	XZM:20000000300323
Impeller - fan aluminum	1	1LA7	XZM:20000000300304
Terminal board	1	1LA7	XZM:27000910420550
Canopy, screw-fixing	1	1LA7	XZM:27000809820150
Frame size 80			
Shaft sealing ring	1	1LA7	–
Endshield drive-end B3	1	1LA7	XZM:27000915130050
Flange drive-end B5	1	1LA7	XZM:27000915132050
Flange drive-end B14 (small)	1	1LA7	XZM:27000915134050
Flange drive-end B14 (large)	1	1LA7	XZM:27000915133050
Fan cover ¹⁾	1	1LA7	XZM:27000807430250
Fan cover ¹⁾	1	1LE10	EWN:50748080200000
Impeller - fan plastic	1	1LA7	XZM:20000000300322
Impeller - fan plastic	1	1LE10	EWN:51458080220001
Impeller - fan aluminum	1	1LA7	XZM:20000000300309
Terminal board	1	1LA7	XZM:27000910420550
Canopy, screw-fixing	1	1LA7	XZM:27000809820150
Frame size 90			
Shaft sealing ring	1	1LA7	–
Endshield drive-end B3	1	1LA7	XZM:27000915141050
Flange drive-end B5	1	1LA7	XZM:27000915142050
Flange drive-end B14 (small)	1	1LA7	XZM:27000915144050
Flange drive-end B14 (large)	1	1LA7	XZM:27000915143050
Fan cover ¹⁾	1	1LA7	XZM:27000807440250
Fan cover ¹⁾	1	1LE10	EWN:50748090200000
Impeller - fan plastic	1	1LA7	XZM:20000000300326
Impeller - fan plastic	1	1LE10	EWN:51458090220001
Impeller - fan aluminum	1	1LA7	XZM:20000000300308
Terminal board	1	1LA7	XZM:27000910420550
Canopy, screw-fixing	1	1LA7	XZM:27000809850050

– Not available

¹⁾ Plastic fan cover for 1LA7 and 1LE10 series, sheet metal fan cover for 1LE0 series.



The parts required for simple modifications of the flange type or replacing parts broken during bearing change are readily available. The retrofitting of an encoder is a common modification. In order to make it easier, we offer the 1LE0 series with a non-drive end shaft mounting facility and the metal fan cover which has been prepared for modification.

User parts	Minimum order quantity	Motor series	Article No.
Frame size 100			
Shaft sealing ring	1	1LE10	XZM:50300100301001
Endshield drive-end B3	1	1LE10	XZM:27000812950890
Flange drive-end B5	1	1LE10	XZM:27000812952590
Flange drive-end B14	1	1LE10	XZM:27000812954790
Fan cover ¹⁾	1	1LE10	XZM:50748100200000
Impeller - fan 2-pole	1	1LE10	XZM:51458112220001
Impeller - fan 4-pole	1	1LE10	XZM:51458112220000
Impeller - fan 6-pole	1	1LE10	XZM:51458100240000
Terminal board	1	1LE10	XZM:27000910450350
Fan cover with canopy	1	1LE10	XZM:50318100310000
Frame size 112			
Shaft sealing ring	1	1LE10	XZM:50300100301001
Endshield drive-end B3	1	1LE10	XZM:27000812960690
Flange drive-end B5	1	1LE10	XZM:27000812962790
Flange drive-end B14	1	1LE10	XZM:27000812964590
Fan cover ¹⁾	1	1LE10	XZM:50748112200000
Impeller - fan 2-pole	1	1LE10	XZM:51458112220000
Impeller - fan 4/6-pole	1	1LE10	XZM:51458112240000
Terminal board	1	1LE10	XZM:27000910450350
Fan cover with canopy	1	1LE10	XZM:27000903160390
Frame size 132			
Shaft sealing ring	1	1LE10	XZM:50300132301001
Endshield drive-end B3	1	1LE10	XZM:27000812970390
Flange drive-end B5	1	1LE10	XZM:27000812972990
Flange drive-end B14	1	1LE10	XZM:27000812974092
Fan cover ¹⁾	1	1LE10	XZM:50748132200500
Impeller - fan 2-pole	1	1LE10	XZM:51458132220000
Impeller - fan 4/6-pole	1	1LE10	XZM:51458132240000
Terminal board	1	1LE10	XZM:27000910470350
Fan cover with canopy	1	1LE10	XZM:27000903170092
Frame size 160			
Shaft sealing ring	1	1LE10	XZM:50300160301001
Endshield drive-end B3	1	1LE10	XZM:27000812981290
Flange drive-end B5	1	1LE10	XZM:27000812982192
Flange drive-end B14	1	1LE10	XZM:27000812984192
Fan cover ¹⁾	1	1LE10	XZM:50748160200500
Impeller - fan 2-pole	1	1LE10	XZM:51458160220000
Impeller - fan 4-pole IE2	1	1LE10	XZM:51458160240001
Impeller - fan 6-pole IE2 / 4/6 pole IE1	1	1LE10	XZM:51458160240000
Terminal board	1	1LE10	XZM:27000910480346
Fan cover with canopy	1	1LE10	XZM:27000903180190

¹⁾ Plastic fan cover for 1LA7 and 1LE10 series, sheet metal fan cover for 1LE0 series.

Note:

The Siemens warranty is valid for all motors which are originally supplied from the Siemens factory. Any modification will result in the nameplate no longer describing the physical build. Any such local adaptation is at the discretion of the user and the quality and func-

tionality is a result of his work. We strongly recommend an additional nameplate to be fixed to the cowl describing those changes referencing the responsible workshop. That workshop carries the warranty for the motor and the associated modification.

Handling and storage

When lifting the motors, always use the lifting eyes provided. Prior to lifting the motor make sure that the lifting eyes are installed correctly and tightened. Never lift a motor using the rotor shaft and fan cowling. In addition, care must be taken during lifting and lowering of the motor to avoid any shocks or vibrations which can result in bearing damages.

It is recommended that all motor be stored in a dry, dust free environment and free of excessive vibrations.

If the DE and NDE bearings are of the sealed types, it is recommended that they are replaced if storage has exceeded 2 years from date of motor manufacture. If the motors have the regreasable bearings, then the recommendation is to replace the grease after 2 years of storage.

The service life of the motor can be considerably reduced if the storage period extends beyond 2 years in environments with high moisture and dirt. If necessary, the insulation resistance of the winding could be measured to determine the health of the motor prior to installation and start-up.

Machined surfaces (flange, DE rotor shaft) are treated at the factory with an anti corrosive agent to prevent rusting. However, these surfaces should be retreated during storage as deemed necessary. It is recommended that the motor shaft is rotated by hand on a frequent basis to ensure even grease distribution.

Certificates

ISO 9001 Quality Management System Certificate



ISO 14001 Environmental Management System Certificate



Notes

Notes

Notes

Siemens AG
Industry Sector
Drive Technologies Division
Large Drives
Postfach 48 48
90026 NÜRNBERG
GERMANY

Subject to change without prior notice
E.9115.63.LDT
BR 0714 80 En
© Siemens AG 2014

The information provided in this brochure contains merely general descriptions or characteristics of performance which in case of actual use do not always apply as described or which may change as a result of further development of the products. An obligation to provide the respective characteristics shall only exist if expressly agreed in the terms of contract. Availability and technical specifications are subject to change without notice. All product designations may be trademarks or product names of Siemens AG or supplier companies whose use by third parties for their own purposes could violate the rights of the owners.