

CR, CRI, CRN, CRE, CRIE, CRNE

Vertical multistage centrifugal pumps
50 Hz



Contents

Product data

Introduction	3
Performance range of CR, CRI, CRN	4
Performance range of CRE, CRIE, CRNE	4
Applications	5
Product range	6
Pump	8
Motor	8
Terminal box positions	9
Ambient temperature	9
Viscosity	9

Control of E-pumps

Examples of E-pump applications	10
Central management system	11
Remote control	11
Control panel	11
Control modes for E-pumps	12
CRE, CRIE, CRNE with integrated pressure sensor	12
CRE, CRIE and CRNE without sensor	12

Construction

CRI(E), CRN(E) 1s, 1, 3, 5, 10, 15 and 20	13
CR(E) 32, 45, 64 and 90	13
CRN(E) 32, 45, 64 and 90	14
CR 120 and 150	14
CRN 120 and 150	15
Type keys	16

Operating and inlet pressures

Maximum operating pressure and temperature range	17
Operating range of the shaft seal	17
Maximum inlet pressure	18

Selection and sizing

Selection of pumps	19
WinCAPS and WebCAPS	20
How to read the curve charts	23
Guidelines to performance curves	23

Performance curves/ technical data

CRI, CRN 1s	24
CRI, CRN, CRIE, CRNE 1	26
CRI, CRN, CRIE, CRNE 3	28
CRI, CRN, CRIE, CRNE 5	30
CRI, CRN, CRIE, CRNE 10	32
CRI, CRN, CRIE, CRNE 15	34
CRI, CRN, CRIE, CRNE 20	36
CR, CRE 32	38
CRN, CRNE 32	39
CR, CRE 45	41
CRN, CRNE 45	44
CR, CRE 64	46
CRN, CRNE 64	48

CR, CRE 90	50
CRN, CRNE 90	52
CR 120	54
CRN 120	56
CR 150	58
CRN 150	60

Single phase motor data

Electrical data 240/1/50	62
Dimensions	62

Motor data

Standard motors for CR, CRI, CRN, 50 Hz	63
E-motors for CRE, CRIE, CRNE, 50 Hz	63

Motor starting

Motor starting	64
----------------	----

Pumped liquids

Pumped liquids	65
List of pumped liquids	65

Accessories

Counter flanges for CRI(E) and CRN(E)	67
PJE couplings for CRN(E)	69
FlexiClamp base connections	69
Pipework connection	71
Counter flanges for CR(E)	71
Potentiometer for CRE, CRIE, CRNE	72
G10-LON interface for CRE, CRIE, CRNE	72
LiqTec for CR(E), CRI(E) and CRN(E)	72
Remote control, R100	72
EMC filter for CRE, CRIE, CRNE	72
Sensors for CRE, CRIE, CRNE	73

Variants

Lists of variants - on request	74
--------------------------------	----

Further product documentation

WebCAPS	75
WinCAPS	76

Introduction

This data booklet deals with CR, CRI and CRN as well as CRE, CRIE and CRNE pumps.



GR5381

Fig. 1 CR, CRI and CRN pumps

CR, CRI, CRN

CR, CRI and CRN pumps are vertical multistage centrifugal pumps. The in-line design enables the pump to be installed in a horizontal one-pipe system where the suction and discharge ports are in the same horizontal plane and have the same pipe dimensions. This design provides a more compact pump design and pipework.

Grundfos CR pumps are available in various sizes and various numbers of stages to provide the flow and pressure required.

CR pumps are designed for a variety of applications from the pumping of potable water to the pumping of chemicals. The pumps are therefore suitable for a wide diversity of pumping systems where the performance and material of the pump meet specific demands.

The CR pumps consist of two main components: The motor and the pump unit. The CR pump motor is a Grundfos motor designed to EN standards.

The pump unit consists of optimised hydraulics, various types of connections, an outer sleeve, a pump head and various other parts.

CR pumps are available in various material versions according to the pumped liquid.

CRE, CRIE, CRNE



TM02 7397 3403

Fig. 2 CRE, CRIE and CRNE pumps

CRE, CRIE and CRNE pumps are built on the basis of CR, CRI, CRN pumps.

CRE, CRIE and CRNE pumps belong to the so-called E-pump family. CRE, CRIE and CRNE pumps are referred to as E-pumps.

The difference between the CR and the CRE pump range is the motor. CRE, CRIE and CRNE pumps are fitted with an E-motor, i.e. a motor with built-in frequency control.

The CRE pump motor is a Grundfos MGE or MMGE motor designed to EN standards.

Frequency control enables continuously variable control of motor speed, which makes it possible to set the pump to operation at any duty point. The aim of continuously variable control of the motor speed is to adjust the performance to a given requirement.

CRE, CRIE and CRNE pumps are available with an integrated pressure sensor connected to the frequency control.

The pump materials are identical to those of the CR, CRI and CRN pump range.

Selecting a CRE pump

Select a CRE pump if the following features are required:

- Controlled operation, i.e. consumption fluctuates
- Constant pressure
- Communication with the pump.

Adaptation of performance through frequency-controlled speed control offers obvious benefits such as:

- energy savings
- increased comfort
- control and monitoring of the pump performance.

Performance range of CR, CRI, CRN

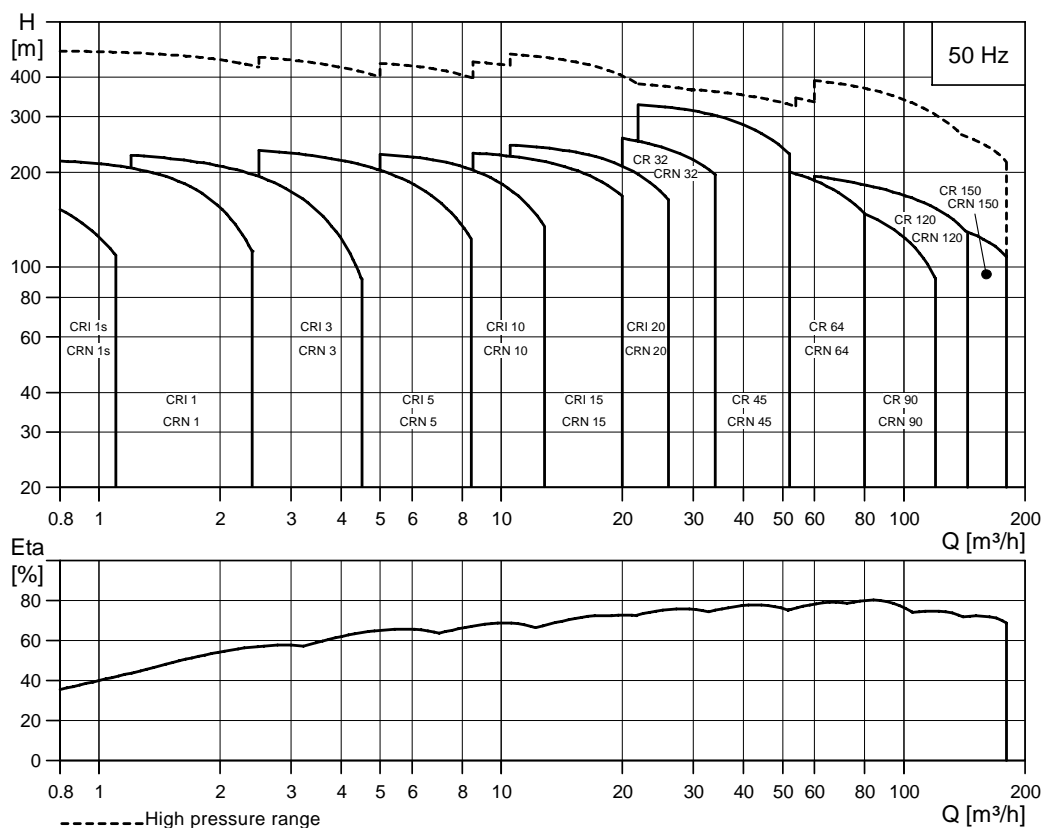

TM03 1688 5107

Performance range of CRE, CRIE, CRNE

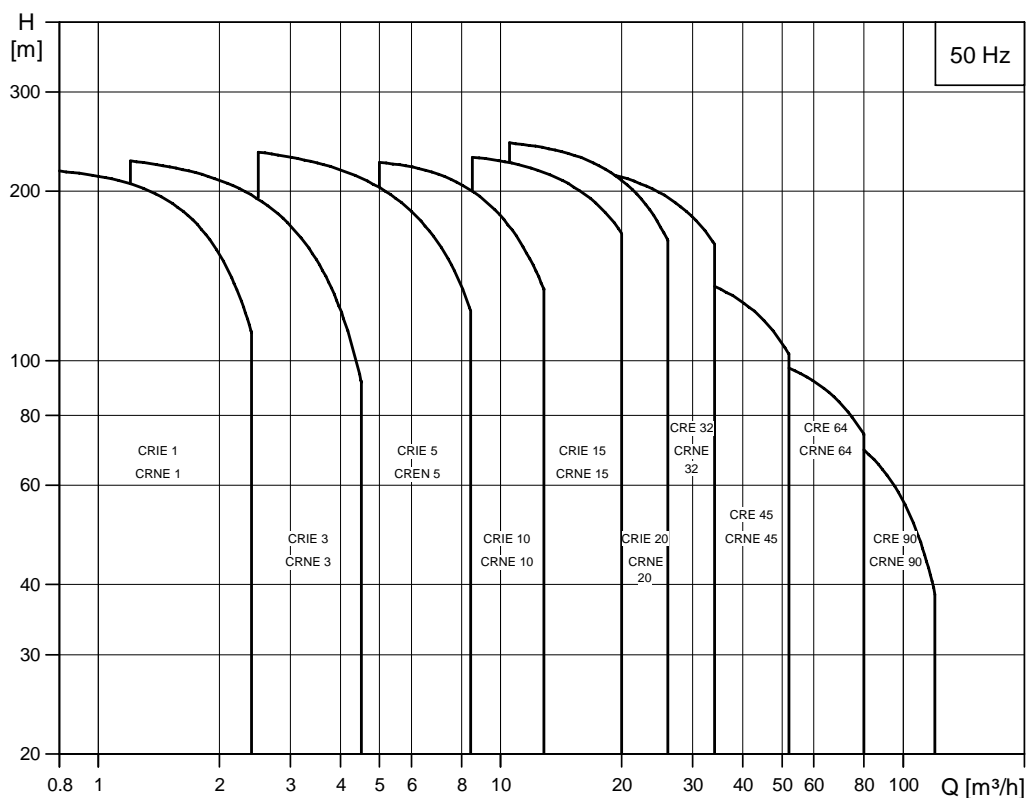

TM03 1689 2705

Applications

Application	CR, CRI	CRN	CRE, CRNE
Water supply			
Filtration and transfer at waterworks	●	○	●
Distribution from waterworks	●	○	●
Pressure boosting in mains	●	○	●
Pressure boosting in high-rise buildings, hotels, etc.	●	○	●
Pressure boosting for industrial water supply	●	○	●
Industry			
Pressure boosting			
Process-water systems	●	●	●
Washing and cleaning systems	●	●	○
Vehicle-washing tunnels	●	○	●
Fire-fighting systems	●		○
Liquid transfer			
Cooling and air-conditioning systems (refrigerants)	●	○	●
Boiler-feed and condensate systems	●	○	●
Machine tools (cooling lubricants)	●	●	●
Aquafarming★	●	○	
Special transfer duties			
Oils and alcohols	●	●	
Acids and alkalis★		●	
Glycol and coolants	●		
Water treatment			
Ultra-filtration systems		●	
Reverse-osmosis systems★		●	
Softening, ionising, demineralising systems		●	
Distillation systems		●	
Separators	●	●	●
Swimming baths★		●	
Irrigation			
Field irrigation (flooding)	●	○	
Sprinkler irrigation	●	○	●
Drip-feed irrigation	●	○	

● Recommended version.

○ Alternative version.

★ CRT, CRTE version available.

For further information about CRT, CRTE pumps, see "Pumped liquids", page 65, or related CRT, CRTE data booklet.

Product range

Range	CRI 1s	CRI, CRIE 1	CRI, CRIE 3	CRI, CRIE 5	CRI, CRIE 10	CRI, CRIE 15	CRI, CRIE 20
Nominal flow rate [m ³ /h]	0.8	1	3	5	10	15	20
Temperature range [°C]	-20 to +120						
Temperature range [°C] – on request	-40 to +180						
Max. pump efficiency [%]	35	48	58	66	70	72	72
CRI pumps							
Flow range [m ³ /h]	0.3-1.1	0.7-2.4	1.2-4.5	2.5-8.5	5-13	9-24	11-29
Max. pressure [bar]	21	22	24	24	22	23	25
High pressure [bar] – on request	-	47	41	47	44	47	48
Motor power [kW]	0.37-1.1	0.37-2.2	0.37-3	0.37-5.5	0.37-7.5	1.1-15	1.1-18.5
CRIE pumps							
Flow range [m ³ /h]	-	0.7-2.4	1.2-4.5	2.5-8.5	5-13	8.5-23.5	10.5-29
Max. pressure [bar]	-	22	24	24	22	23	25
Motor power [kW]	-	0.37-2.2	0.37-3	0.37-5.5	0.37-7.5	1.1-15	1.1-18.5
Version							
CRI, CRIE: Stainless steel EN 1.4301/AISI 304	•	•	•	•	•	•	•
CRN, CRNE: Stainless steel EN 1.4401/AISI 316	•	•	•	•	•	•	•
CRT, CRTE: Titanium	See the CRT, CRTE data booklet.						
CRI, CRIE pipe connection							
Oval flange (BSP)	Rp 1	Rp 1	Rp 1¼	Rp 1¼	Rp 1½	-	-
Oval flange (BSP) on request	Rp 1¼	Rp 1¼	Rp 1	Rp 1	Rp 2	-	-
Flange	-	-	-	-	DN 50	DN 50	DN 50
Flange on request	-	-	-	-	DN 50	-	-
PJE coupling (Victaulic)	R 1¼ DN 32	R 1¼ DN 32	R 1¼ DN 32	R 1¼ DN 32	R 2 DN 50	R 2 DN 50	R 2 DN 50
Clamp coupling (L-coupling)	Ø48.3	Ø48.3	Ø48.3	Ø48.3	Ø60.3	Ø60.3	Ø60.3
Union (+GF+)	G 2	G2	G 2	G 2	G 2¾	G 2¾	G 2¾
CRN(E) pipe connection							
Flange	DN 25/ DN 32	DN 25/ DN 32	DN 25/ DN 32	DN 25/ DN 32	DN 40	DN 50	DN 50
Flange on request	-	-	-	-	DN 50	-	-
PJE coupling (Victaulic)	R 1¼ DN 32	R 1¼ DN 32	R 1¼ DN 32	R 1¼ DN 32	R 2 DN 50	R 2 DN 50	R 2 DN 50
Clamp coupling (L-coupling)	Ø48.3	Ø48.3	Ø48.3	Ø48.3	Ø60.3	Ø60.3	Ø60.3
Union (+GF+)	G 2	G2	G 2	G 2	G 2¾	G 2¾	G 2¾

Product data

CR, CRI, CRN,
CRE, CRIE, CRNE

Range	CR, CRE 32	CR, CRE 45	CR, CRE 64	CRI CRE 90	CR 120	CR 150
Nominal flow rate [m ³ /h]	32	45	64	90	120	150
Temperature range [°C]	-30 to +120 ¹⁾					
Temperature range [°C] – on request	-40 to +180					
Max. pump efficiency [%]	78	79	80	81	75	72
CR pumps						
Flow range [m ³ /h]	15-40	22-58	30-85	45-120	60-160	75-180
Max. pressure [bar]	28	33	22	20	21	19
High pressure [bar] – on request	39	39	39	41	41	39
Motor power [kW]	1.5-30	3-45	4-45	5.5-45	11-75	11-75
CRIE pumps						
Flow range [m ³ /h]	15-40	22-58	30-85	45-120	-	-
Max. pressure [bar]	28	26	20	20	-	-
Motor power [kW]	1.5-22	3-22	4-22	5.5-22	-	-
Version						
CR, CRE: Cast iron and stainless steel EN 1.4301/AISI 304	•	•	•	•	•	•
CRN, CRNE: Stainless steel EN 1.4401/AISI 316	•	•	•	•	•	•
CRT, CRTE: Titanium	See the CRT, CRTE data booklet.				-	-
CR, CRE pipe connection						
Oval flange (BSP)	-	-	-	-	-	-
Oval flange (BSP) on request	-	-	-	-	-	-
Flange	DN 65	DN 80	DN 100	DN 100	DN 125	DN 125
Flange on request	DN 80	DN 100	DN 125	DN 125	DN 150	DN 150
CRI, CRIE pipe connection						
Oval flange (BSP)	-	-	-	-	-	-
Oval flange (BSP) on request	-	-	-	-	-	-
Flange	-	-	-	-	-	-
Flange on request	-	-	-	-	-	-
PJE coupling (Victaulic)	-	-	-	-	-	-
Clamp coupling (L-coupling)	-	-	-	-	-	-
Union (+GF+)	-	-	-	-	-	-
CRN(E) pipe connection						
Oval flange (BSP)	-	-	-	-	-	-
Oval flange (BSP) on request	-	-	-	-	-	-
Flange	DN 65	DN 80	DN 100	DN 100	DN 125	DN 125
Flange on request	DN 80	DN 100	DN 125	DN 125	DN 150	DN 150
PJE coupling (Victaulic)	3" ²⁾	4" ²⁾	4" ²⁾	4" ²⁾	-	-
Clamp coupling (L-coupling)	-	-	-	-	-	-
Union (+GF+)	-	-	-	-	-	-

¹⁾ CRN 32 to CRN 90 with HQQE shaft seal: -40 °C to 120 °C

²⁾ On request. See the CR "Custom-built pumps" catalogue.

Pump

The CR and CRE pumps are non-self-priming, vertical multistage centrifugal pumps.

The pumps are available with a Grundfos standard motor (CR pumps) or a frequency-controlled motor (CRE pumps).

The pump consists of a base and a pump head. The chamber stack and the outer sleeve are secured between the pump head and the base by means of staybolts. The base has suction and discharge ports on the same level (in-line). All pumps are equipped with a maintenance-free mechanical shaft seal of the cartridge type.

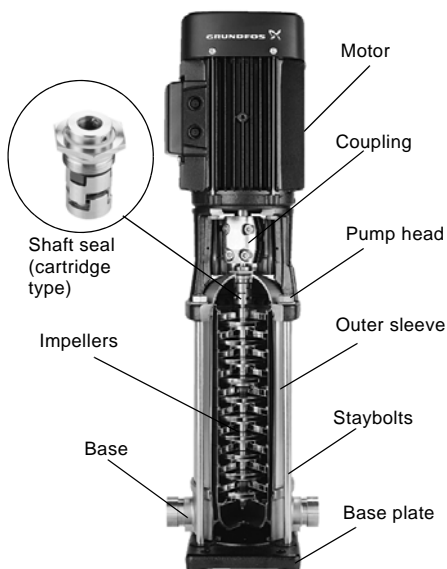

Fig. 3 CR pump

GR5357 - GR3395

Motor

Grundfos standard motors: MG and Siemens motors

CR, CRI and CRN pumps are fitted with a totally enclosed, fan-cooled, 2-pole Grundfos standard motor with principal dimensions to EN standards.

Electrical tolerances according to EN 60034.

CR, CRI, CRN pumps are fitted with three-phase MG motors as standard.

CR, CRI, CRN pumps from 0.37 to 2.2 kW are also available with single-phase motors (1 x 220-230/240 V). See Win-/WebCAPS.

Frequency-controlled motors: MGE

CRE, CRIE and CRNE pumps are fitted with a totally enclosed, fan-cooled, 2-pole frequency-controlled motor with principal dimensions to EN standards.

Electrical tolerances comply with EN 60034.

CRE, CRIE, CRNE pumps from 0.37 to 1.1 kW are fitted with single-phase MGE motors as standard.

CRE, CRIE, CRNE pumps from 0.75 to 1.1 kW are also available with three-phase MGE motors. See Win-/WebCAPS.

Electrical data

CR, CRI, CRN

	MG motor
Mounting designation	Up to 4 kW: V 18 From 5.5 kW: V 1
Insulation class	F
Efficiency class	EFF 1 (0.37-0.75 kW pumps are EFF 2)
Enclosure class	IP 55★
	P ₂ : 0.37-1.5 kW: 3 x 220-240/380-415 V
Supply voltage (Tolerance: ±10%)	P ₂ : 2.2-11 kW: 3 x 380-415 V
	P ₂ : 15-75 kW: 3 x 380-415/660-690 V
Supply frequency	50 Hz

★ IP 44, IP 54 and IP 65 are available on request.

CRE, CRIE, CRNE

	MGE motor (P ₂ ≤ 7.5 kW)	MMGE motor (P ₂ ≥ 11-22 kW)
Mounting designation	Up to 4 kW: V 18 From 5.5 kW: V 1	
Insulation class	F	
Efficiency class	EFF 1★	EFF 2
Enclosure class	IP 54	
	P ₂ : 0.37-1.1 kW: 1 x 200-240 V	P ₂ : 11-22 kW: 3 x 380-415 V
Supply voltage (Tolerance: ±10%)	P ₂ : 0.75-7.5 kW: 3 x 380-480 V	
Supply frequency	50/60 Hz	

★ Single-phase MGE motors are EFF 2.

Optional motors

The Grundfos standard range of motors covers a wide variety of application demands. However, for special applications or operating conditions, custom-built motor solutions can be provided.

For special applications or operating conditions, Grundfos offers custom-built motors such as:

- ATEX-approved motors
- MG motors with anti-condensation heating unit
- motors with thermal protection.

Motor protection

MG and Siemens motors

Single-phase Grundfos motors have a built-in thermal overload switch (IEC 34-11: TP 211).

Three-phase motors **must** be connected to a motor starter in accordance with local regulations.

Three-phase Grundfos motors from 3 kW and upwards have a built-in thermistor (PTC) according to DIN 44 082 (IEC 34-11: TP 211).

MGE motors

CRE, CRIE, CRNE pumps require no external motor protection. The MGE motor incorporates thermal protection against slow overloading and blocking (IEC 34-11: TP 211).

Terminal box positions

As standard the terminal box is mounted on the suction side of the pump.

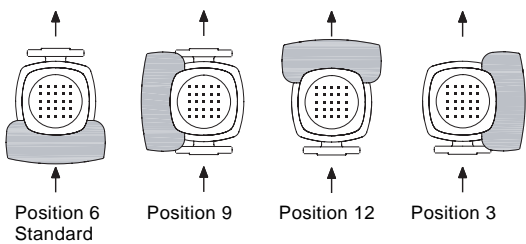

Fig. 4 Terminal box positions

TM03 3658 0606

Ambient temperature

Motor power [kW]	Motor make	Motor efficiency class	Maximum ambient temperature [°C]	Maximum altitude above sea level [m]
0.37-0.75	Grundfos MG	EFF 2	+40	1000
1.1-11	Grundfos MG	EFF 1	+60	3500
15-75	Siemens	EFF 1	+55	2750

If the ambient temperature exceeds the above temperature values or the pump is installed at an altitude exceeding the above altitude values, the motor must not be fully loaded due to the risk of overheating. Overheating may result from excessive ambient temperatures or the low density and consequently low cooling effect of the air.

In such cases, it may be necessary to use a motor with a higher rated output.

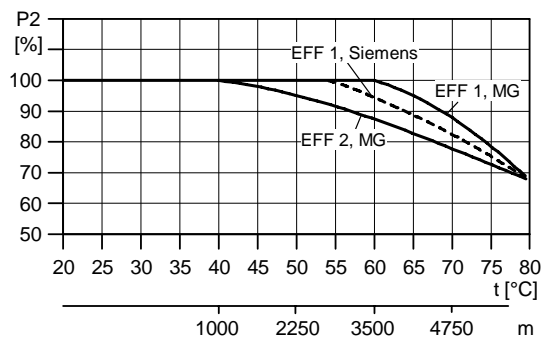

Fig. 5 Motor output depends on temperature/altitude

TM03 1868 3305

Viscosity

The pumping of liquids with densities or kinematic viscosities higher than those of water will cause a considerable pressure drop, a drop in the hydraulic performance and a rise in the power consumption.

In such situations the pump should be equipped with a larger motor. If in doubt, contact Grundfos.

Examples of E-pump applications

CRE, CRIE and CRNE pumps are the ideal choice for a number of applications characterised by a need for variable flow at constant pressure. The pumps are suited for water supply systems and pressure boosting as well as for industrial applications.

Depending on the application, the pumps offer energy-savings, increased comfort and improved processing.

E-pumps in the service of industry

Industry uses a large number of pumps in many different applications. Demands on pumps in terms of pump performance and mode of operation make speed control a must in many applications.

Below is listed some of the applications in which E-pumps are often used.

Constant pressure

- water supply
- washing and cleaning systems
- distribution from waterworks
- humidifying systems
- water treatment systems
- process boosting systems, etc.

Example: Within industrial water supply, E-pumps with integrated pressure sensor are used to ensure a constant pressure in the piping network. From the sensor, the E-pump receives inputs about changes of pressure as a result of changes in the consumption. The E-pump responds to the input by adjusting the speed until the pressure is equalized. The constant pressure is stabilized once more on the basis of a preset setpoint.

Constant temperature

- air-conditioning systems at industrial plants
- industrial cooling systems
- industrial freezing systems
- casting and moulding tools, etc.

Example: In industrial freezing systems, E-pumps with temperature sensor increase comfort and lower operating costs compared with pumps without a temperature sensor.

An E-pump continuously adapts its performance to the changing demands reflected in the differences in temperature of the liquid circulating in the freezing system. Thus, the lower the demand for cooling, the smaller the quantity of liquid circulated in the system and vice versa.

Constant flow

- steam boiler systems
- condensate systems
- sprinkler irrigation systems
- chemical industry, etc.

Example: In a steam boiler, it is important to be able to monitor and control pump operation to maintain a constant level of water in the boiler.

By using an E-pump with level sensor in the boiler, it is possible to maintain a constant water level.

A constant water level ensures optimum and cost-efficient operation as a result of a stable steam production.

Dosing applications

- chemical industry (i.e. control of pH-values)
- petrochemical industry
- paint industry
- degreasing systems
- bleaching systems, etc.

Example: In the petrochemical industry, E-pumps with pressure sensor are used as dosing pumps. The E-pumps help to ensure that the correct mixture ratio is achieved when more liquids are combined.

E-pumps functioning as dosing pumps improve processing and offer energy-savings.

E-pumps in commercial building services

Commercial building services use E-pumps to maintain a constant pressure or a constant temperature based on a variable flow.

Constant pressure

Water supply in high-rise buildings such as office buildings and hotels.

Example: E-pumps with pressure sensor are used for water supply in high-rise buildings to ensure a constant pressure even at the highest draw-off point. As the consumption pattern and thus the pressure changes during the day, the E-pump continuously adapts its performance until the pressure is equalized.

Constant temperature

- air-conditioning systems in hotels, schools, etc.
- building cooling systems, etc.

Example: E-pumps are an excellent choice for buildings where constant temperature is essential. E-pumps keep the temperature constant in air-conditioned high-rise glass buildings, irrespective of the seasonal fluctuations of the outdoor temperature and various heat impacts inside the building.

Control options of E-pumps

Communication with CRE, CRIE, CRNE pumps is possible by means of either of the following:

- a central management system
- remote control (Grundfos R100)
- a control panel.

The purpose of controlling an E-pump is to monitor and control the pressure, temperature, flow and liquid level of the system.

Central management system

Communication with the E-pump is possible even if the operator is not present near the E-pump. Communication is enabled by connecting the E-pump to a central management system. This allows the operator to monitor the pump and to change control modes and setpoint settings.

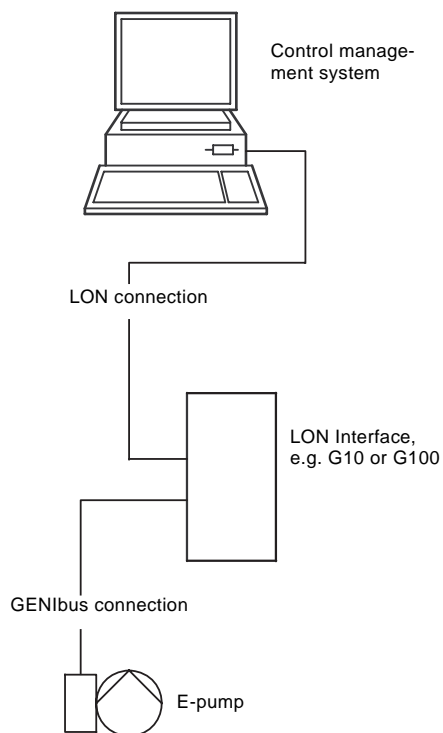

Fig. 6 Structure of a central management system

TM02 6592 1404

Remote control

The R100 remote control produced by Grundfos is available as an accessory.

The operator communicates with the E-pump by pointing the IR-signal transmitter at the control panel of the E-pump terminal box.

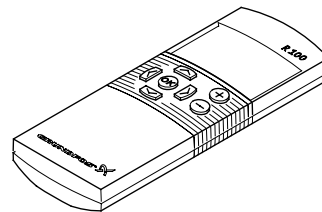

TM00 4498 2802

Fig. 7 R100 remote control

On the R100 display it is possible to monitor and change control modes and settings of the E-pump.

Control panel

The control panel of the E-pump terminal box makes it possible to change the setpoint settings manually.

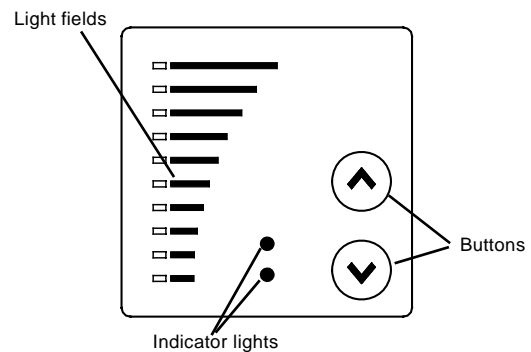

TM00 7600 0404

Fig. 8 Control panel on CRE pump

Control modes for E-pumps

Grundfos offers CRE, CRIE and CRNE pumps in two different variants:

- CRE, CRIE and CRNE with integrated pressure sensor
- CRE, CRIE and CRNE without sensor.

CRE, CRIE, CRNE with integrated pressure sensor

Use CRE, CRIE and CRNE pumps with integrated pressure sensor in applications where you want to control the pressure after the pump, irrespective of the flow. For further information, see the section "Examples of E-pump applications, page 10.

Signals of pressure changes in the piping system are transmitted continuously from the sensor to the pump. The pump responds to the signals by adjusting its performance up or down to compensate for the pressure difference between the actual and the desired pressure. As this adjustment is a continuous process, a constant pressure is maintained in the piping system.



TM02 7398 3403

Fig. 9 CRE, CRIE and CRNE pumps

A CRE, CRIE or CRNE pump with integrated pressure sensor facilitates installation and commissioning.

CRE, CRIE and CRNE pumps with integrated pressure sensor can be set to either of these modes:

- constant-pressure mode (factory setting)
- constant-curve mode.

In **constant-pressure** mode, the pump maintains a preset pressure after the pump, irrespective of the flow, see figure below.

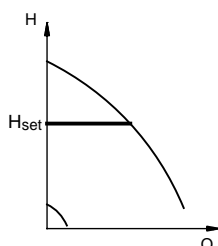

TM00 9322 4796

Fig. 10 Constant pressure mode

In **constant-curve** mode, the pump is not controlled. It can be set to pump according to a preset pump characteristic within the range from min. curve to max. curve, see figure below.

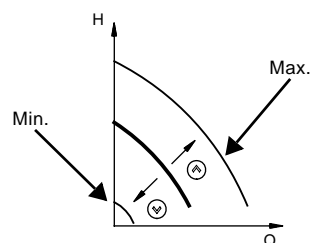

TM00 9323 1204

Fig. 11 Constant curve mode

CRE, CRIE and CRNE without sensor

CRE, CRIE and CRNE pumps without sensor are suitable for applications

- where uncontrolled operation is required
- where you want to fit another sensor later in order to control the flow, temperature, differential temperature, liquid level, pH value, etc. at some arbitrary point in the system.

CRE, CRIE and CRNE pumps without sensor can be set to either of these modes:

- controlled-operation mode
- uncontrolled-operation mode (factory-setting).

In **controlled**-operation mode, the pump adjusts its performance to the desired setpoint, see figure below.

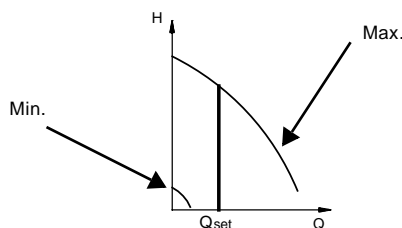

TM02 7264 2803

Fig. 12 Constant flow mode

In **uncontrolled**-operation mode, the pump operates according to the constant curve set, see figure below.

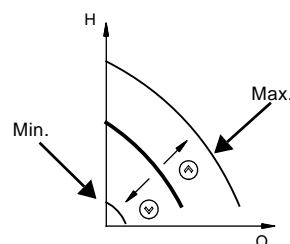

TM00 9323 1204

Fig. 13 Constant curve mode

CRE, CRIE and CRNE pumps can be fitted with sensor types meeting the requirements mentioned in the data booklet titled "Grundfos E-pumps".

CRI(E), CRN(E) 1s, 1, 3, 5, 10, 15 and 20



TM02 1808 2001 - GR7373 - GR7375

Sectional drawing

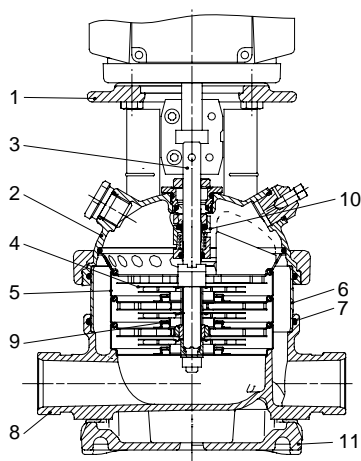

TM02 1195 1403

Materials, CRI(E) and CRN(E)

Pos.	Designation	Materials	EN/DIN	AISI/ASTM
1	Pump head	Cast iron EN-GJL-200 ¹⁾	EN-JL1030	ASTM 25B
2	Pump head cover	Stainless steel	1.4408	CF 8M equal to AISI 316
3	Shaft	Stainless steel	1.4401 ²⁾ 1.4460 ³⁾	AISI 316 AISI 329
8	Base	Stainless steel	1.4408	CF 8M equal to AISI 316
9	Neck ring	PTFE		
10	Shaft seal	Cartridge type		
11	Base plate	Cast iron EN-GJL-200 ¹⁾	EN-JL1030	ASTM 25B
Rubber parts		EPDM or FKM		
CRI(E)				
4	Impeller	Stainless steel	1.4301	AISI 304
5	Chamber	Stainless steel	1.4301	AISI 304
6	Outer sleeve	Stainless steel	1.4401	AISI 316
7	O-ring for outer sleeve	EPDM or FKM		
CRN(E)				
4	Impeller	Stainless steel	1.4401	AISI 316
5	Chamber	Stainless steel	1.4401	AISI 316
6	Outer sleeve	Stainless steel	1.4401	AISI 316
7	O-ring for outer sleeve	EPDM or FKM		

¹⁾ Stainless steel available on request.

²⁾ CRI(E), CRN(E) 1S, 1, 3, 5

³⁾ CRI(E), CRN(E) 10, 15, 20

CR(E) 32, 45, 64 and 90



TM01 2150 1298 - GR5952

Sectional drawing

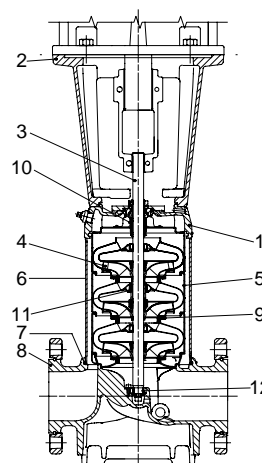

TM01 1836 1403

Materials, CR(E)

Pos.	Designation	Materials	EN/DIN	AISI/ASTM
1	Pump head	Cast iron EN-GJS-500-7	EN-JS1050	ASTM 80-55-06
2	Motor stool	Cast iron EN-GJL-200	EN-JL1030	ASTM 25B
3	Shaft	Stainless steel	1.4057	AISI 431
4	Impeller	Stainless steel	1.4301	AISI 304
5	Chamber	Stainless steel	1.4301	AISI 304
6	Outer sleeve	Stainless steel	1.4301	AISI 304
7	O-ring for outer sleeve	EPDM or FKM		
8	Base	Cast iron EN-GJS-500-7	EN-JS1050	ASTM 80-55-06
9	Neck ring	Carbon-graphite-filled PTFE		
10	Shaft seal			
11	Bearing ring	Bronze		
12	Bottom bearing ring	Tungsten carbide/ tungsten carbide		
Rubber parts		EPDM or FKM		

CRN(E) 32, 45, 64 and 90



TM02 7399 3403

Sectional drawing

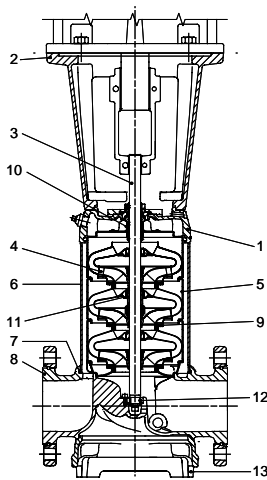

TM01 1837 1403

Materials, CRN(E)

Pos.	Designation	Materials	EN/DIN	AISI/ASTM
1	Pump head	Stainless steel	1.4408	CF 8M equal to AISI 316
2	Motor stool	Cast iron EN-GJL-200 1)	EN-JL1030	ASTM 25B
3	Shaft	Stainless steel	1.4462	
4	Impeller	Stainless steel	1.4401	AISI 316
5	Chamber	Stainless steel	1.4401	AISI 316
6	Outer sleeve	Stainless steel	1.4401	AISI 316
7	O-ring for outer sleeve	EPDM or FKM		
8	Base	Stainless steel	1.4408	CF 8M equal to AISI 316
9	Neck ring	Carbon-graphite filled PTFE		
10	Shaft seal			
11	Bearing ring	Carbon-graphite filled PTFE		
12	Bottom bearing ring	Tungsten carbide/tungsten carbide		
13	Base plate	Stainless steel 2)	1.4408	CF 8M equal to AISI 316
	Rubber parts	EPDM or FKM		

¹ Stainless steel available on request.

² Stainless steel available on request for CRNE pumps, standard base plate for CRNE is cast iron.

CR 120 and 150



GrA3731

Sectional drawing

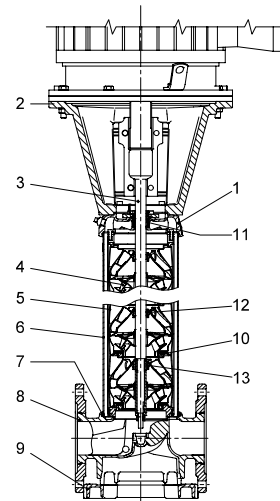

TM03 8835 2607

Materials, CR

Pos.	Designation	Materials	EN/DIN	AISI/ASTM
1	Pump head	Cast iron EN-GJS-500-7	EN-JS1050	A 536 65-45-12
2	Motor stool (11-45 kW)	Cast iron EN-GJL-200	EN-JL1030	A48-30 B
	Motor stool (55-75 kW)	Cast iron EN-GJS-500-7	EN-JS1050	A 536 65-45-12
3	Shaft	Stainless steel	1.4057	AISI 431
4	Impeller	Stainless steel	1.4301	AISI 304
5	Chamber	Stainless steel	1.4301	AISI 304
6	Outer sleeve	Stainless steel	1.4401	AISI 316
7	O-ring for outer sleeve	EPDM or FKM		
8	Base	Cast iron EN-GJS-500-7	EN-JS1050	A 536 65-45-12
9	Base plate	Cast iron EN-GJS-500-7	EN-JS1050	A 536 65-45-12
10	Neck ring	PTFE		
11	Shaft seal ¹⁾	SiC/SiC (Ø22) Carbon/SiC (Ø32)		
12	Support bear- ing	PTFE		
13	Bearing ring	SiC/SiC		
	Rubber parts	EPDM or FKM		

¹⁾ Ø22 mm shaft, 11-45 kW. Ø32 mm shaft, 55-75 kW.

CRN 120 and 150



GrA3732 - GrA3735

Sectional drawing

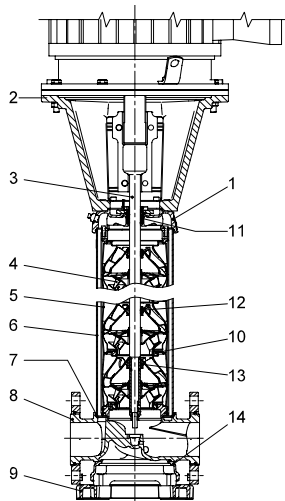

TM03 8836 2607

Materials, CRN

Pos.	Designation	Materials	EN/DIN	AISI/ASTM
1	Pump head	Stainless steel	1.4408	A 351 CF 8M
2	Motor stool (11-45 kW)	Cast iron EN-GJL-200	EN-JL1030	A48-30 B
	Motor stool (55-75 kW)	Cast iron EN-GJS-500-7	EN-JS1050	A 536 65-45-12
3	Shaft	Stainless steel	1.4462	SAF 2205
4	Impeller	Stainless steel	1.4401	AISI 316
5	Chamber	Stainless steel	1.4401	AISI 316
6	Outer sleeve	Stainless steel	1.4401	AISI 316
7	O-ring for outer sleeve	EPDM or FKM		
8	Base	Stainless steel	1.4408	A 351 CF 8M
9	Base plate	Stainless steel ¹⁾	1.4408	A 351 CF 8M
10	Neck ring	PTFE		
11	Shaft seal ²⁾	SiC/SiC (Ø22) Carbon/SiC (Ø32)		
12	Support bearing	PTFE		
13	Bearing ring	SiC/SiC		
14	Base plate	Stainless steel ¹⁾	1.4408	A 351 CF 8M
	Rubber parts	EPDM or FKM		

¹⁾ Cast iron available on request.

²⁾ Ø22 mm shaft, 11-45 kW. Ø32 mm shaft, 55-75 kW.

Type keys

CR(E), CRI(E), CRN(E)

Example	CR E 32(s) -4 -2 -A -F -G -E -HQQE
Type range: CR, CRI, CRN	
Pump with integrated frequency control	
Flow rate [m ³ /h]	
All impellers with reduced diameter (applies only to CR, CRI, CRN 1s)	
Number of impellers	
Number of reduced-diameter impellers (CR(E), CRN(E) 32, 45, 64, 90, 120 and 150)	
Code for pump version	
Code for pipe connection	
Code for materials	
Code for rubber parts	
Code for shaft seal	

Codes

Example	A	-F	-A	-E	-H	QQ	E
Pump version							
A Basic version							
B Oversize motor							
E Pump with certificate/approval							
F CR pump for high temperatures (air-cooled top assembly)							
H Horizontal version							
HS High-pressure pump with high speed MGE motor							
I Different pressure rating							
J Pump w/different max. speed							
K Pump with low NPSH							
M Magnetic drive							
N Fitted with sensor							
P Undersize motor							
R Horizontal version with bearing bracket							
SF High pressure pump							
X Special version							
Pipe connection							
A Oval flange							
B NPT thread							
CA FlexiClamp (CRI(E), CRN(E) 1, 3, 5, 10, 15, 20)							
F DIN flange							
G ANSI flange							
J JIS flange							
N Changed diameter of ports							
P PJE coupling							
X Special version							
Materials							
A Basic version							
D Carbon-graphite-filled PTFE (bearings)							
G Wetted parts 1.4401/AISI 316							
GI All parts stainless steel, wetted parts 1.4401/AISI 316							
I Wetted parts 1.4301/AISI 304							
II All parts stainless steel, wetted parts 1.4301/AISI 304							
K Bronze (bearings)							
S SiC bearings + PTFE neck rings							
X Special version							
Code for rubber parts							
E EPDM							
F FXM							
K FFKM							
V FKM							
Shaft seal							
H Balanced cartridge seal							
Q Silicon carbide							
U Tungsten carbide							
B Carbon							
E EPDM							
F FXM							
K FFKM							
V FKM							

Maximum inlet pressure

The following table shows the maximum permissible inlet pressure. However, the current inlet pressure + the pressure against a closed valve **must** always be lower than the maximum permissible operating pressure.

If the maximum permissible operating pressure is exceeded, the conical bearing in the motor may be damaged and the life of the shaft seal reduced.

CRI, CRN 1s		
1s-2	› 1s-36	10 bar
GRI(E), CRN(E) 1		
1-2	› 1-36	10 bar
CRI(E), CRN(E) 3		
3-2	› 3-29	10 bar
3-31	› 3-36	15 bar
CRI(E), CRN(E) 5		
5-2	› 5-16	10 bar
5-18	› 5-36	15 bar
CRI(E), CRN(E) 10		
10-1	› 10-6	8 bar
10-7	› 10-22	10 bar
CRI(E), CRN(E) 15		
15-1	› 15-3	8 bar
15-4	› 15-17	10 bar
CRI(E), CRN(E) 20		
20-1	› 20-3	8 bar
20-4	› 20-17	10 bar
CR(E), CRN(E) 32		
32-1-1	› 32-4	4 bar
32-5-2	› 32-10	10 bar
32-11	› 32-14	15 bar
CR(E), CRN(E) 45		
45-1-1	› 45-2	4 bar
45-3-2	› 45-5	10 bar
45-6-2	› 45-13-2	15 bar
CR(E), CRN(E) 64		
64-1-1	› 64-2-2	4 bar
64-2-1	› 64-4-2	10 bar
64-4-1	› 64-8-1	15 bar
CR(E), CRN(E) 90		
90-1-1	› 90-1	4 bar
90-2-2	› 90-3-2	10 bar
90-3	› 90-6	15 bar
CR, CRN 120		
120-1	› 120-2-1	10 bar
120-2	› 120-5-1	15 bar
120-6-1	› 120-7	20 bar
CR, CRN 150		
150-1-1	› 150-1	10 bar
150-2-1	› 150-4-2	15 bar
150-5-2	› 150-6	20 bar

Examples of operating and inlet pressures

The values for operating and inlet pressures shown in the table should not be considered individually but should always be compared, see the following examples:

Example 1:

The following pump type has been selected:
CRI 5-16 A-CA-A

Max. operating pressure: **16 bar**

Max. inlet pressure: **10 bar**

Discharge pressure against a closed valve: **10.6 bar**, see page 30.

This pump is **not** allowed to start at an inlet pressure of 10 bar, but at an inlet pressure of $16.0 - 10.6 = 5.4$ bar.

Example 2:

The following pump type has been selected:
CRI 10-2 A-CA-A

Max. operating pressure: **16 bar**

Max. inlet pressure: **8.0 bar**

Discharge pressure against a closed valve: **2.0 bar**, see page 32.

This pump is allowed to start at an inlet pressure of 8.0 bar, as the discharge pressure against a closed valve is only 2.0 bar, which results in an operating pressure of $8.0 + 2.0 = 10.0$ bar. On the contrary, the max. operating pressure of this pump is limited to 16.0 bar, as a higher operating pressure will require an inlet pressure of more than 8.0 bar.

In case the inlet or operating pressure exceeds the pressure permitted, see "Variants on request", page 74.

Selection of pumps

Selection of pumps should be based on these elements:

- the duty point of the pump (see page 19)
- dimensional data such as pressure loss as a result of height differences, friction loss in the pipework, pump efficiency etc. (see page 19)
- pump materials (see page 21)
- pump connections (see page 21)
- shaft seal (see page 21).

Duty point of the pump

From a duty point it is possible to select a pump on the basis of the curve charts shown in "Performance curves/technical data" from page 24.

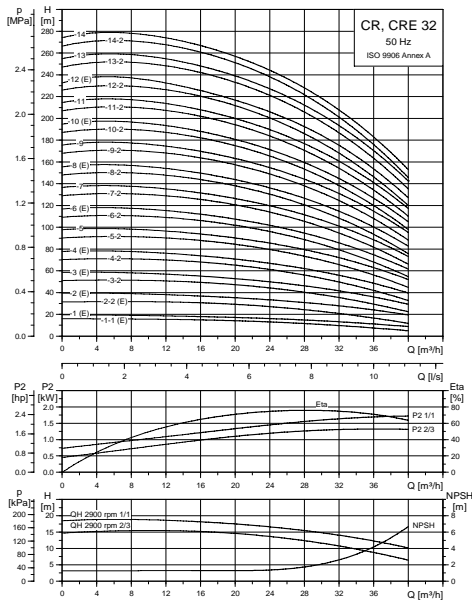

Fig. 15 Example of a curve chart

Dimensional data

When sizing a pump, take the following factors into account:

- Required flow and pressure at the draw-off point.
- Pressure loss as a result of height differences (H_{geo}).
- Friction loss in the pipework (H_f).
It may be necessary to account for pressure loss in connection with long pipes, bends or valves, etc.
- Best efficiency at the estimated duty point.
- NPSH value.
For calculation of the NPSH value, see "Minimum inlet pressure, NPSH, page 22.

Pump efficiency

Before determining the best efficiency point, the operation pattern of the pump needs to be identified. Is the pump expected to operate at the **same** duty point, then select a CR pump which is operating at a duty point corresponding with the best efficiency of the pump.

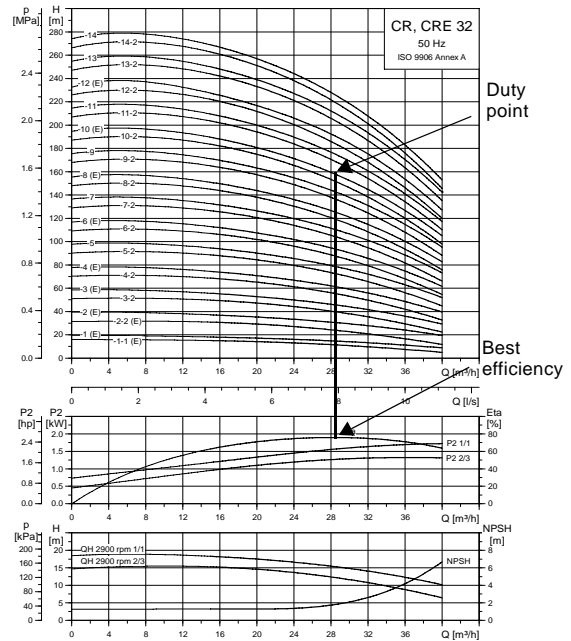

Fig. 16 Example of a CR pump's duty point

As the pump is sized on the basis of the highest possible flow, it is important always to have the duty point to the right on the efficiency curve (eta) in order to keep efficiency high when the flow drops.

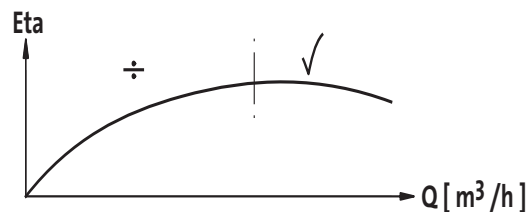

Fig. 17 Best efficiency

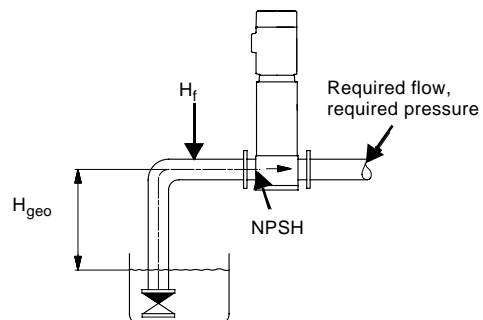

Fig. 18 Dimensional data

Normally, E-pumps are used in applications characterized by a **variable** flow. Consequently, it is not possible to select a pump that is constantly operating at optimum efficiency.

In order to achieve optimum operating economy, the pump should be selected on the basis of the following criteria:

- The max. duty point required should be as close as possible to the QH curve of the pump.
- The required duty point should be positioned so that P_2 is close to the max. point of the QH curve.

Between the min. and max. performance curve, E-pumps have an infinite number of performance curves each representing a specific speed. Therefore it may not be possible to select a duty point close to the 100 % curve.

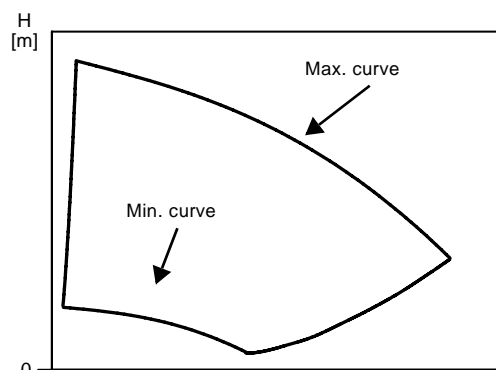

Fig. 19 Min. and max. performance curves

In situations where it is not possible to select a duty point close to the 100 % curve the below affinity equations can be used. The head (H), the flow (Q) and the input power (P) are all the appropriate variables for the motor speed (n).

Note:

The approximated formulas apply on condition that the system characteristic remains unchanged for n_n and n_x and that it is based on the formula $H = k \times Q^2$, where k is a constant.

The power equation implies that the pump efficiency is unchanged at the two speeds. In practice, this is **not** quite correct.

To obtain a precise calculation of the power savings resulting from a reduction of pump speed, take into account the efficiencies of the frequency converter and the motor.

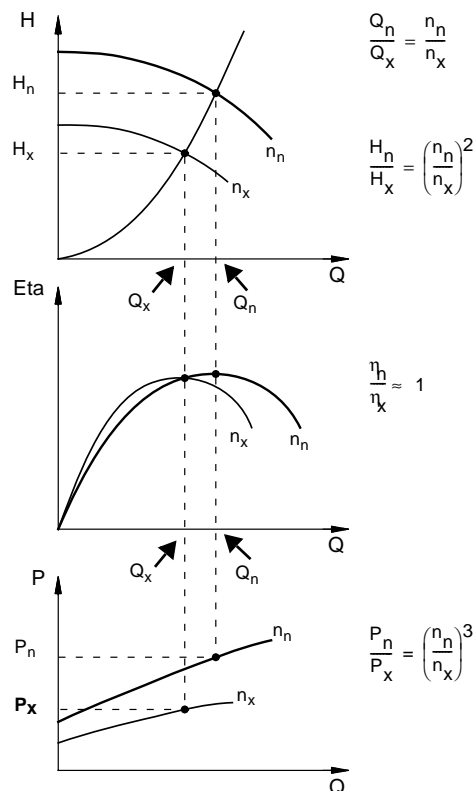

Fig. 20 Affinity equations

Legend

- H_n Rated head in metres
- H_x Current head in metres
- Q_n Rated flow in m^3/h
- Q_x Current flow in m^3/h
- n_n Rated motor speed in min^{-1} ($n_n = 2900 min^{-1}$)
- n_x Current motor speed in min^{-1}
- η_h Rated efficiency in %
- η_k Current efficiency in %

WinCAPS and WebCAPS

WinCAPS and WebCAPS are both selection programmes offered by Grundfos.

The two programmes make it possible to calculate an E-pump's specific duty point and energy consumption.

By entering the dimensional data of the pump, WinCAPS and WebCAPS can calculate the exact duty point and energy consumption. For further information, see pages 75 and 76.

Pump material

Select the material variant (CR(E), CRI(E), CRN(E)) on the basis of the liquid to be pumped. The product range covers the following three basic types.

- CR(E), CRI(E)
Use CR(E), CRI(E) pumps for clean, non-aggressive liquids such as potable water and oils.
- CRN(E)
Use CRN(E) pumps for industrial liquids and acids. See "List of pumped liquids", page 65, or contact Grundfos.

For saline or chloride-containing liquids such as sea water, CRT(E) pumps of titanium are available.

Pump connections

Selection of pump connection depends on the rated pressure and pipework. To meet any requirement, the CR(E), CRI(E) and CRN(E) pumps offer a wide range of flexible connections such as:

- oval flange (BSP)
- DIN flange
- PJE coupling
- clamp coupling
- union (+GF+)
- other connections on request.

Shaft seal

As standard, the CR(E) range is fitted with a Grundfos shaft seal (cartridge type) suitable for the most common applications.

These key parameters **must** be taken into account when selecting the shaft seal:

- type of pumped liquid
- liquid temperature
- maximum pressure.

Grundfos offers a wide range of shaft seal variants to meet specific demands. See "List of pumped liquids", page 65.

Inlet pressure and operating pressure

Do **not** exceed the limit values stated on pages 17 and 18 as regards these pressures:

- maximum inlet pressure
- maximum operating pressure.

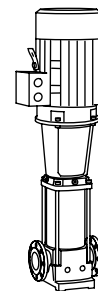

Fig. 21 CR pump

TM01 2100 1198

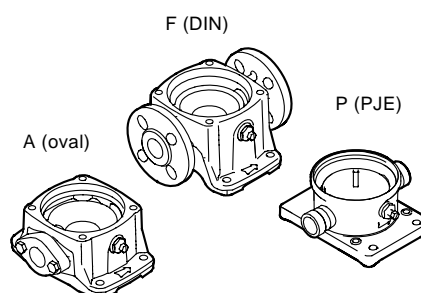

Fig. 22 Pump connections

TM02 1201 0601

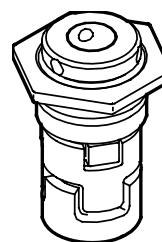

Fig. 23 Shaft seal (cartridge type)

TM02 0538 4800

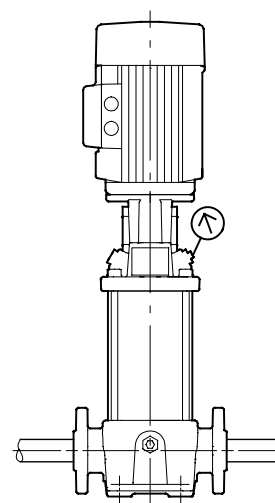

Fig. 24 Inlet and operating pressure

TM02 1204 060

Minimum inlet pressure, NPSH

Calculation of the inlet pressure "H" is recommended in these situations:

- The liquid temperature is high.
- The flow is significantly higher than the rated flow.
- Water is drawn from depths.
- Water is drawn through long pipes.
- Inlet conditions are poor.

To avoid cavitation, make sure that there is a minimum pressure on the suction side of the pump. The maximum suction lift "H" in metres head can be calculated as follows:

$$H = p_b \times 10.2 - \text{NPSH} - H_f - H_v - H_s$$

p_b = Barometric pressure in bar.
(Barometric pressure can be set to 1 bar).
In closed systems, p_b indicates the system pressure in bar.

NPSH = Net Positive Suction Head in metres head.
(To be read from the NPSH curve at the highest flow the pump will be delivering.)

H_f = Friction loss in suction pipe in metres head.
(At the highest flow the pump will be delivering.)

H_v = Vapour pressure in metres head.
(To be read from the vapour pressure scale.
" H_v " depends on the liquid temperature " T_m ".)

H_s = Safety margin = minimum 0.5 metres head.

If the "H" calculated is positive, the pump can operate at a suction lift of maximum "H" metres head.

If the "H" calculated is negative, an inlet pressure of minimum "H" metres head is required.

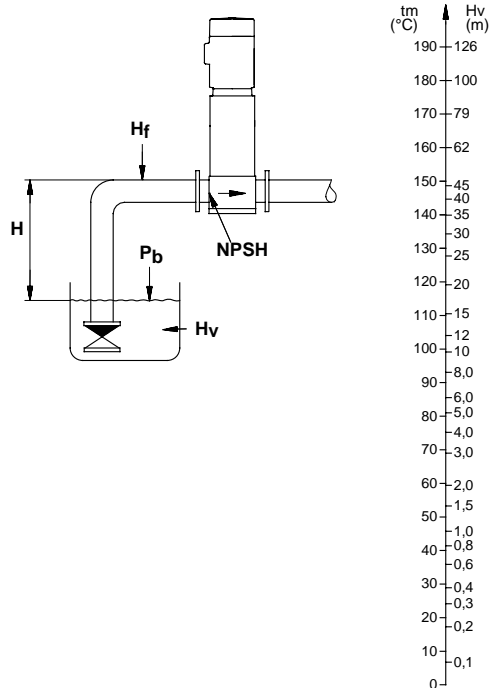

Fig. 25 Minimum inlet pressure - NPSH

Note: To avoid cavitation, **never** select a pump with a duty point too far to the right on the NPSH curve.

Always check the NPSH value of the pump at the highest possible flow.

TM02 7439 3-403

How to read the curve charts

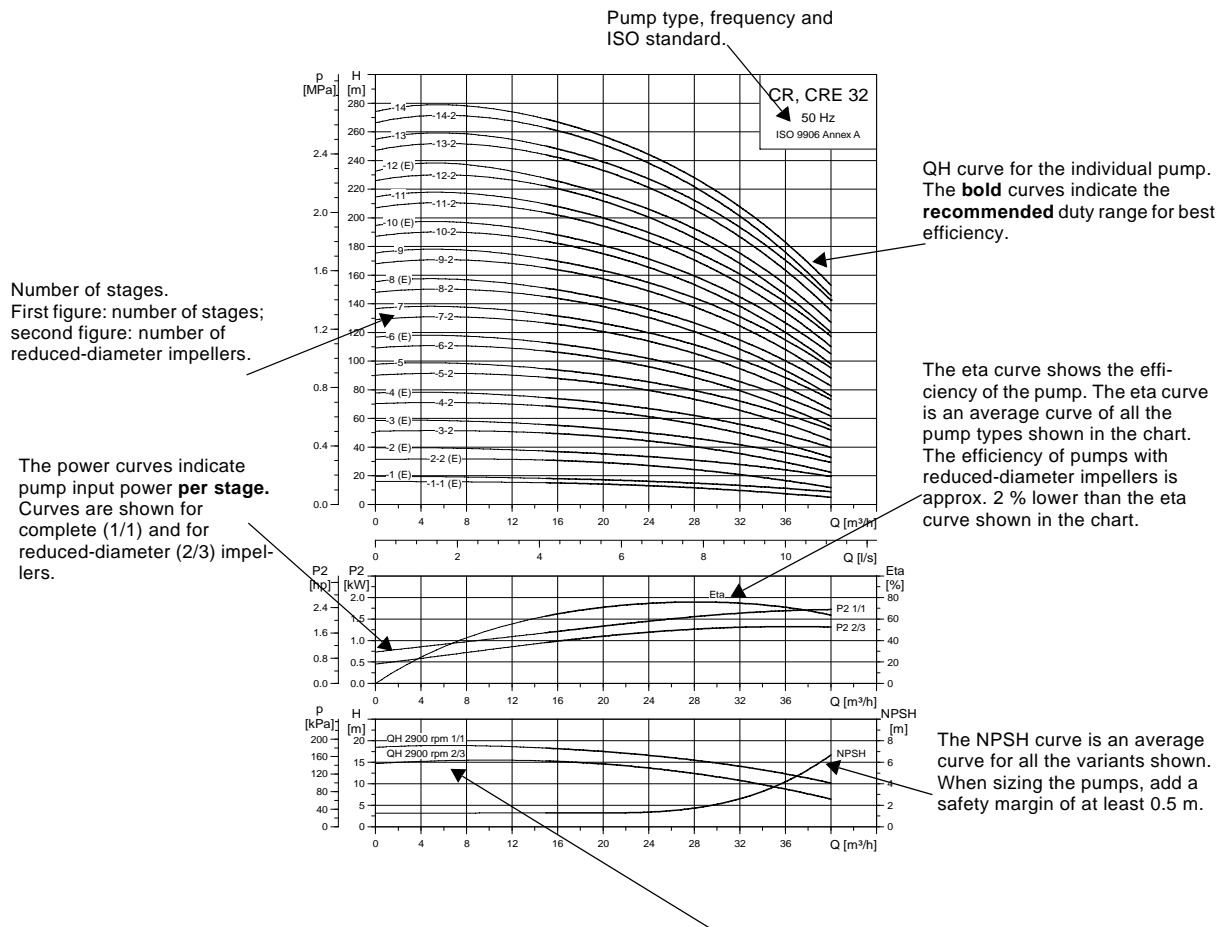

QH curve for each individual impeller. Curves for complete (1/1) and reduced-diameter (2/3) impellers are shown.

Fig. 26 How to read the curve charts

TM02 7302 3103

Guidelines to performance curves

The guidelines below apply to the curves shown on the following pages:

- Tolerances to ISO 9906, Annex A, if indicated.
- The motors used for the measurements are standard Grundfos motors (MG or MGE).
- Measurements have been made with airless water at a temperature of 20 °C.
- The curves apply to the following kinematic viscosity: $\nu = 1 \text{ mm}^2/\text{s}$ (1 cSt).
- Due to the risk of overheating, the pumps should not be used at a flow below the minimum flow rate.
- The QH curves apply to a rated motor speed of 2900 min^{-1} . All curves are based on current motor speeds.

The curve below shows the minimum flow rate as a percentage of the nominal flow rate in relation to the liquid temperature. The dotted line shows a CR pump fitted with an air-cooled top assembly.

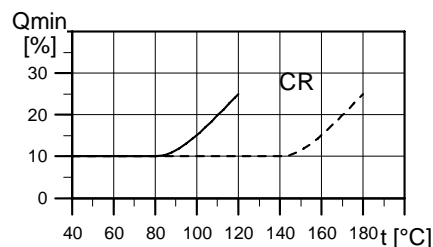
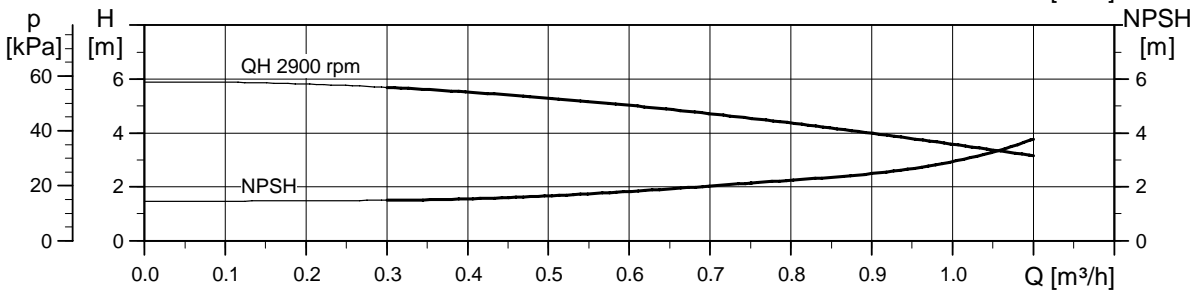
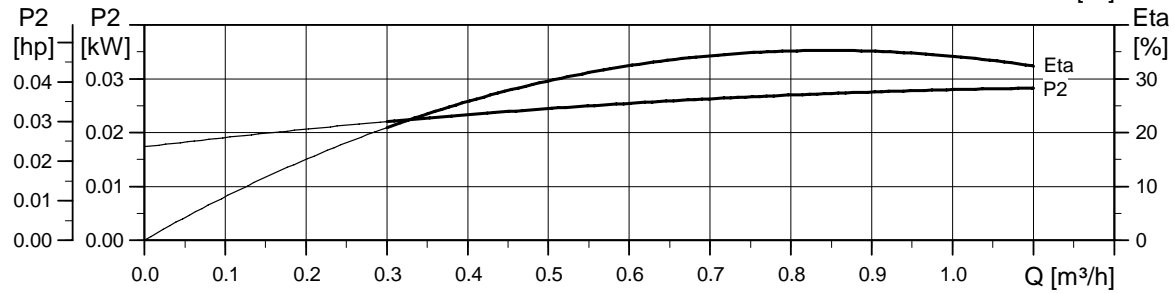
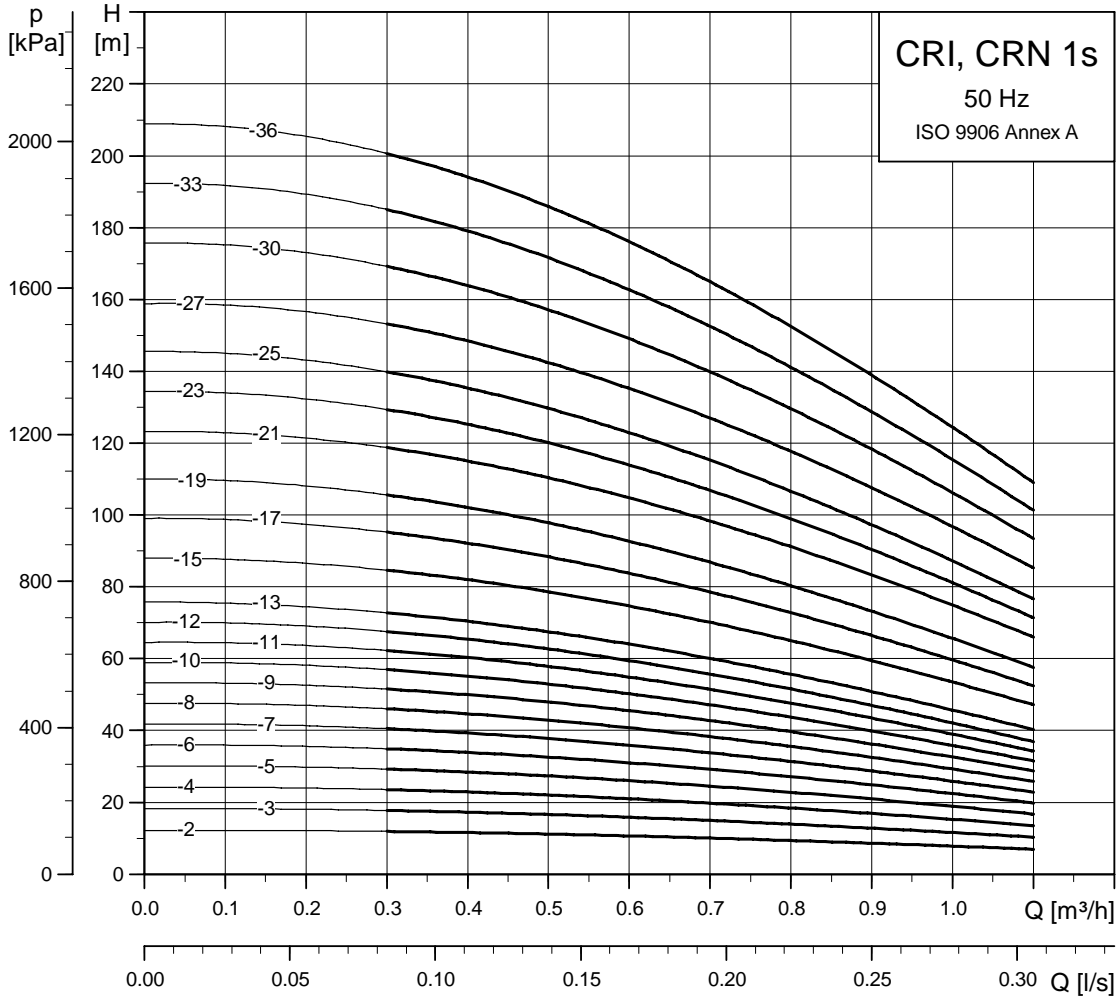

Fig. 27 Minimum flow rate

TM01 2816 0303

CRI, CRN 1s



TM02 7425 3605

Dimensional sketch

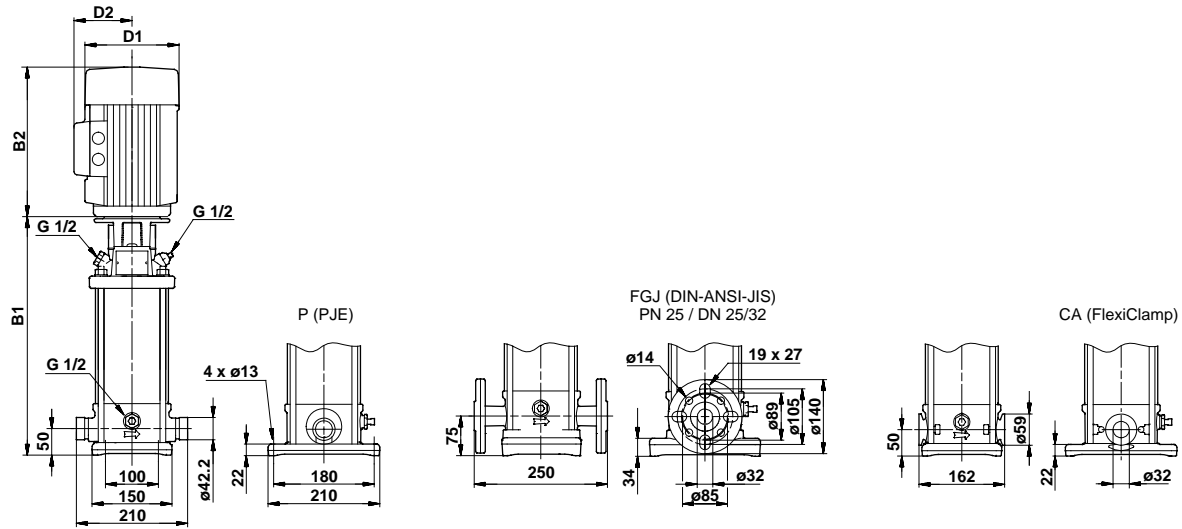

TM03 1722 2805

Dimensions and weights

Pump type	Motor P ₂ [kW]	Dimension [mm]						Net weight [kg]	
		PJE/CA		DIN flange		B2	D1		D2
		B1	B1+B2	B1	B1+B2				
CRI/CRN 1s-2	0.37	257	448	282	473	141	109	16	20
CRI/CRN 1s-3	0.37	257	448	282	473	141	109	16	21
CRI/CRN 1s-4	0.37	275	466	300	491	141	109	17	21
CRI/CRN 1s-5	0.37	293	484	318	509	141	109	17	21
CRI/CRN 1s-6	0.37	311	502	336	527	141	109	18	22
CRI/CRN 1s-7	0.37	329	520	354	545	141	109	18	22
CRI/CRN 1s-8	0.37	347	538	372	563	141	109	18	23
CRI/CRN 1s-9	0.37	365	556	390	581	141	109	19	23
CRI/CRN 1s-10	0.37	383	574	408	599	141	109	19	23
CRI/CRN 1s-11	0.37	401	592	426	617	141	109	19	24
CRI/CRN 1s-12	0.37	419	610	444	635	141	109	20	24
CRI/CRN 1s-13	0.37	437	628	462	653	141	109	20	25
CRI/CRN 1s-15	0.55	473	664	498	689	141	109	22	26
CRI/CRN 1s-17	0.55	509	700	534	725	141	109	23	27
CRI/CRN 1s-19	0.55	545	736	570	761	141	109	23	28
CRI/CRN 1s-21	0.75	587	818	612	843	141	109	26	31
CRI/CRN 1s-23	0.75	623	854	648	879	141	109	27	31
CRI/CRN 1s-25	0.75	659	890	684	915	141	109	28	32
CRI/CRN 1s-27	1.1	695	926	720	951	141	109	31	35
CRI/CRN 1s-30	1.1	749	980	774	1005	141	109	32	36
CRI/CRN 1s-33	1.1	803	1034	828	1059	141	109	33	37
CRI/CRN 1s-36	1.1	857	1088	882	1113	141	109	34	39

CA is the code for the FlexiClamp coupling.
 CRI 1s pump models have a CA base up to the 1-19, suitable for use with two bolt oval flanges.
 CRI 1s pump models from 1-21 and above have a FGJ base for use with a four bolt DIN flange.
 CRN 1 models are available with either PJE of FGJ connections.
 CRI 1s and CRN 1s models with DIN flanges are rated DN25/32, PN25.
 The recommended connection size is DN25.

CRI, CRN, CRIE, CRNE 1

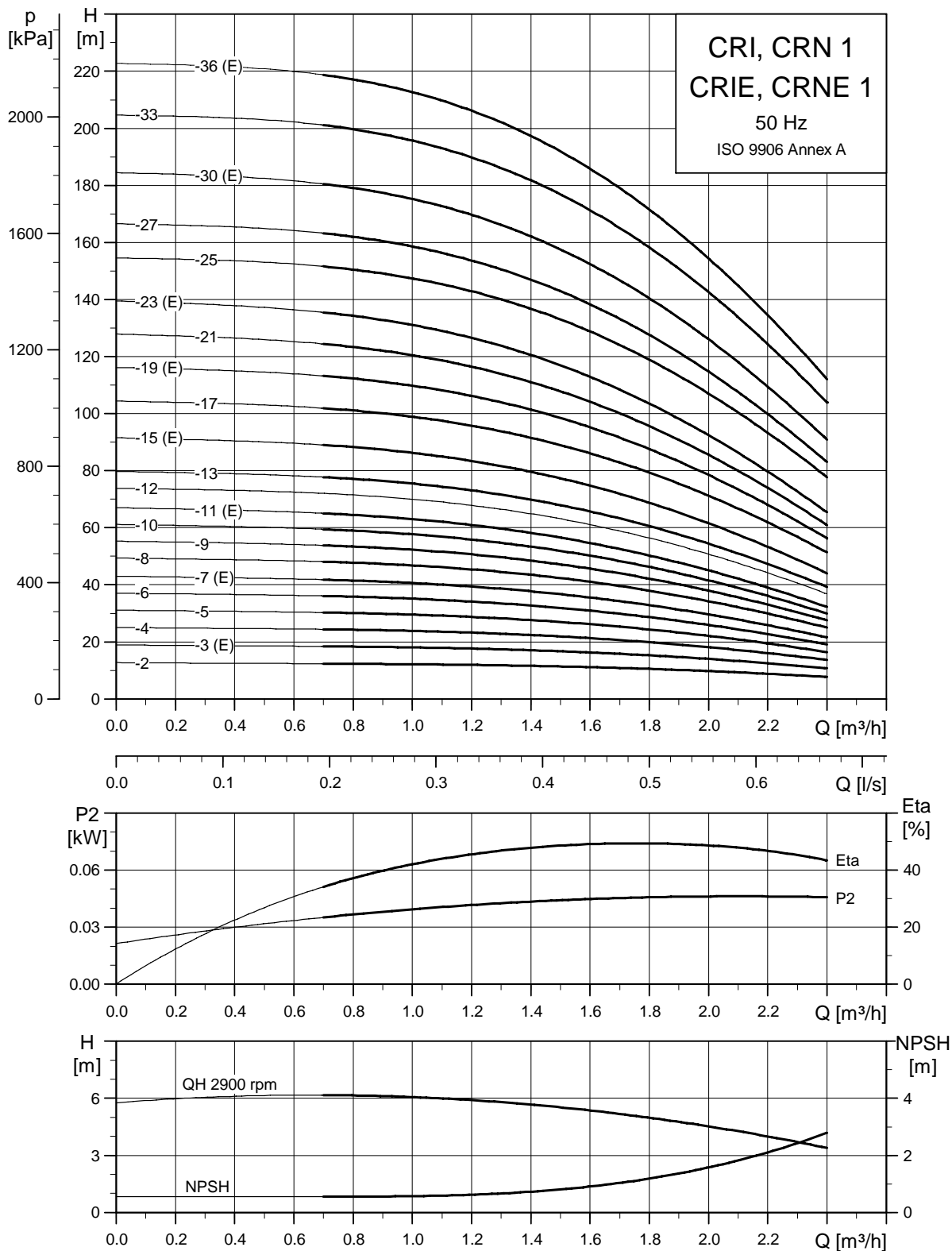

TM02 7291 3605

Dimensional sketch

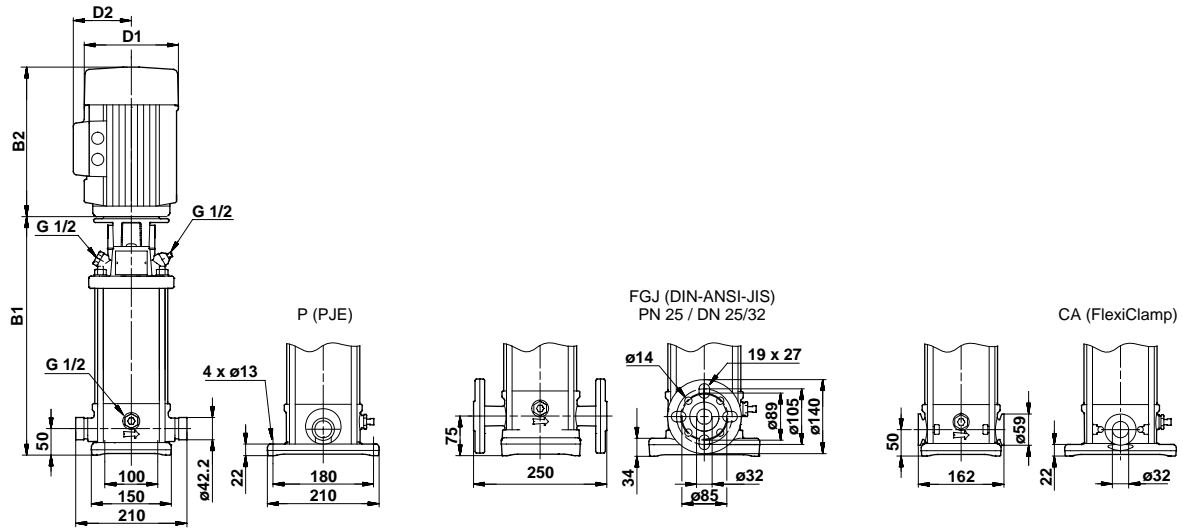

TM03 1722 2805

Dimensions and weights

Pump type	Motor P ₂ [kW]	CRI/CRN								CRIE/CRNE							
		Dimension [mm]				Net weight [kg]				Dimension [mm]				Net weight [kg]			
		PJE/CA		DIN flange		D1	D2	PJE/CA	DIN flange	PJE/CA		DIN flange		PJE/CA	DIN flange		
B1	B1+B2	B1	B1+B2	B1	B1+B2					B1	B1+B2						
CRI/CRN 1-2	0.37	257	448	282	473	141	109	16	20	-	-	-	-	-	-	-	-
CRI(E)/CRN(E) 1-3	0.37	257	448	282	473	141	109	16	21	257	448	282	473	141	140	19	23
CRI/CRN 1-4	0.37	275	466	300	491	141	109	17	21	-	-	-	-	-	-	-	-
CRI/CRN 1-5	0.37	293	484	318	509	141	109	17	21	-	-	-	-	-	-	-	-
CRI/CRN 1-6	0.37	311	502	336	527	141	109	18	22	-	-	-	-	-	-	-	-
CRI(E)/CRN(E) 1-7	0.37	329	520	354	545	141	109	18	22	329	520	354	545	141	140	21	25
CRI/CRN 1-8	0.55	347	538	372	563	141	109	19	23	-	-	-	-	-	-	-	-
CRI/CRN 1-9	0.55	365	556	390	581	141	109	20	24	-	-	-	-	-	-	-	-
CRI/CRN 1-10	0.55	383	574	408	599	141	109	20	24	-	-	-	-	-	-	-	-
CRI(E)/CRN(E) 1-11	0.55	401	592	426	617	141	109	20	24	401	592	426	617	141	140	23	27
CRI/CRN 1-12	0.75	425	656	450	681	141	109	23	27	-	-	-	-	-	-	-	-
CRI/CRN 1-13	0.75	443	674	468	699	141	109	23	28	-	-	-	-	-	-	-	-
CRI(E)/CRN(E) 1-15	0.75	479	710	504	735	141	109	24	28	479	710	504	735	178	167	27	31
CRI/CRN 1-17	1.1	515	746	540	771	141	109	27	31	-	-	-	-	-	-	-	-
CRI(E)/CRN(E) 1-19	1.1	551	782	576	807	141	109	28	32	551	782	576	807	178	167	30	34
CRI/CRN 1-21	1.1	587	818	612	843	141	109	29	33	-	-	-	-	-	-	-	-
CRI(E)/CRN(E) 1-23	1.1	623	854	648	879	141	109	30	34	623	854	648	879	178	167	32	36
CRI/CRN 1-25	1.5	675	956	700	981	178	110	37	41	-	-	-	-	-	-	-	-
CRI/CRN 1-27	1.5	711	992	736	1017	178	110	38	42	-	-	-	-	-	-	-	-
CRI(E)/CRN(E) 1-30	1.5	765	1046	790	1071	178	110	39	43	765	1046	790	1071	178	167	46	50
CRI/CRN 1-33	2.2	819	1140	844	1165	178	110	41	45	-	-	-	-	-	-	-	-
CRI(E)/CRN(E) 1-36	2.2	873	1194	898	1219	178	110	42	46	873	1194	898	1219	178	167	52	56

CA is the code for the FlexiClamp coupling.

CRI(E) 1 pump models have a CA base up to the 1-19, suitable for use with two bolt oval flanges.

CRI(E) 1 pump models from 1-21 and above have a FGJ base for use with a four bolt DIN flange.

CRN(E) 1 models are available with either PJE of FGJ connections.

CRI(E) 1 & CRN 1 models with DIN flanges are rated DN25/32, PN25.

The recommended connection size is DN25.

CRI, CRN, CRIE, CRNE 3

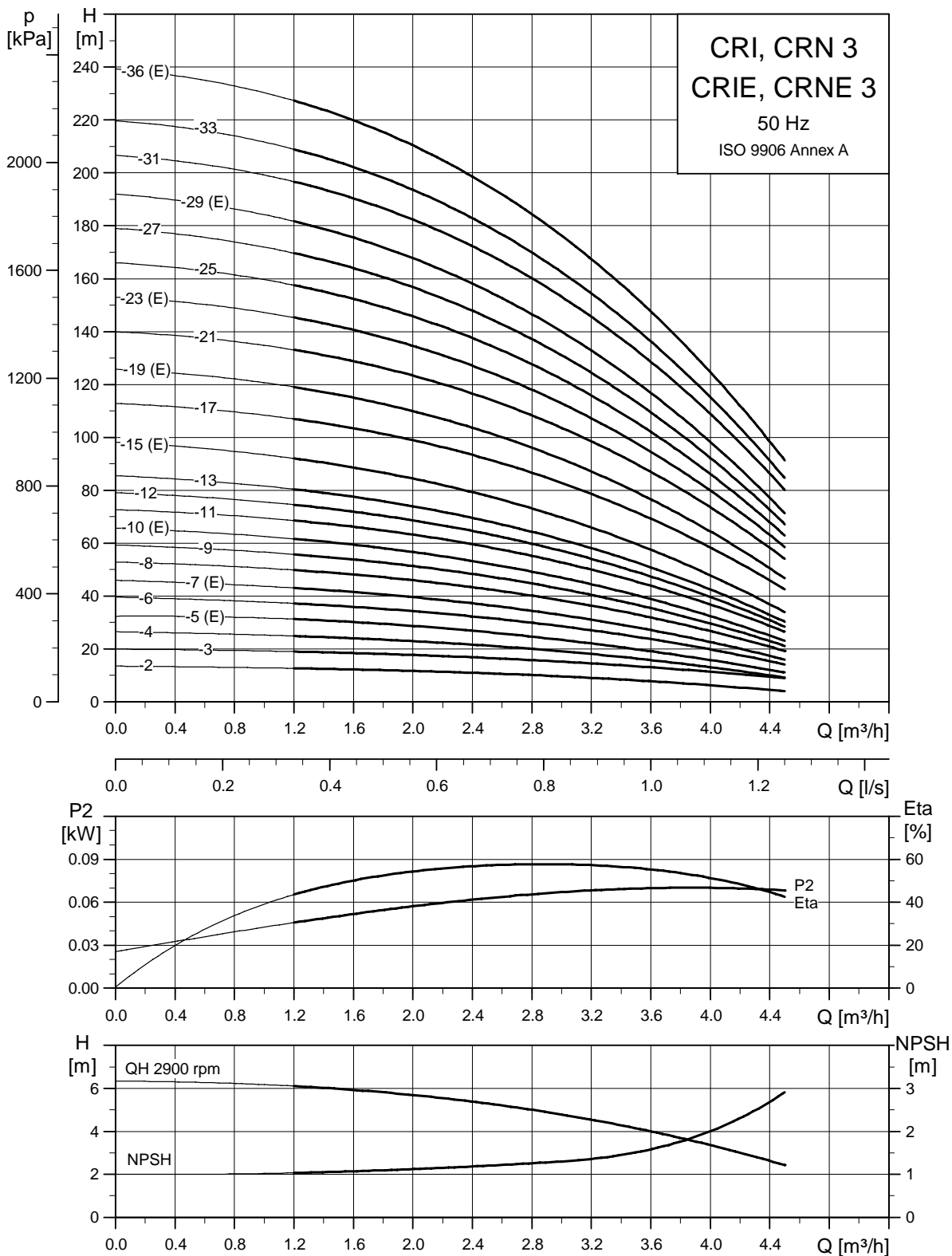

TM02 7293 3605

Dimensional sketch

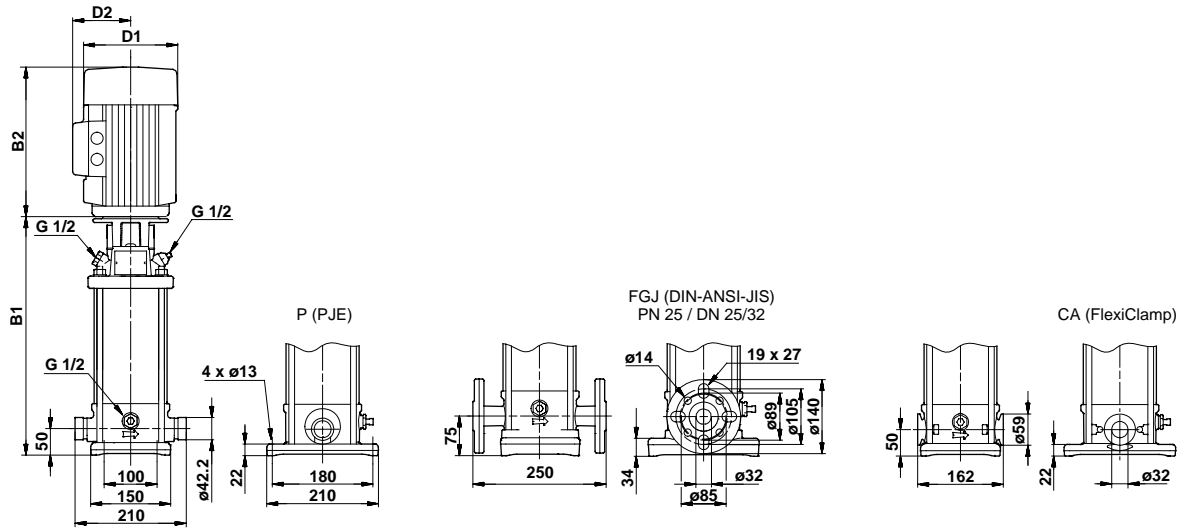

TM03 1722 2805

Dimensions and weights

Pump type	Motor P ₂ [kW]	CRI/CRN								CRIE/CRNE							
		Dimension [mm]				Net weight [kg]				Dimension [mm]				Net weight [kg]			
		PJE/CA		DIN flange		D1	D2	PJE/CA	DIN flange	PJE/CA		DIN flange		D1	D2	PJE/CA	DIN flange
B1	B1+B2	B1	B1+B2					B1	B1+B2	B1	B1+B2						
CRI/CRN 3-2	0.37	257	448	282	473	141	109	16	20	-	-	-	-	-	-	-	
CRI/CRN 3-3	0.37	257	448	282	473	141	109	16	21	-	-	-	-	-	-	-	
CRI/CRN 3-4	0.37	275	466	300	491	141	109	17	21	-	-	-	-	-	-	-	
CRI(E)/CRN(E) 3-5	0.37	293	484	318	509	141	109	17	21	293	484	318	509	141	140	20	24
CRI/CRN 3-6	0.55	311	502	336	527	141	109	18	23	-	-	-	-	-	-	-	
CRI(E)/CRN(E) 3-7	0.55	329	520	354	545	141	109	19	23	329	520	354	545	141	140	21	26
CRI/CRN 3-8	0.75	353	584	378	609	141	109	21	26	-	-	-	-	-	-	-	
CRI/CRN 3-9	0.75	371	602	396	627	141	109	22	26	-	-	-	-	-	-	-	
CRI(E)/CRN(E) 3-10	0.75	389	620	414	645	141	109	22	26	389	620	414	645	178	167	25	29
CRI/CRN 3-11	1.1	407	638	432	663	141	109	25	29	-	-	-	-	-	-	-	
CRI/CRN 3-12	1.1	425	656	450	681	141	109	25	29	-	-	-	-	-	-	-	
CRI/CRN 3-13	1.1	443	674	468	699	141	109	26	30	-	-	-	-	-	-	-	
CRI(E)/CRN(E) 3-15	1.1	479	710	504	735	141	109	26	31	479	710	504	735	178	167	29	33
CRI/CRN 3-17	1.5	531	812	556	837	178	110	34	38	-	-	-	-	-	-	-	
CRI(E)/CRN(E) 3-19	1.5	567	848	592	873	178	110	34	39	567	848	592	873	178	167	41	45
CRI/CRN 3-21	2.2	603	924	628	949	178	110	36	40	-	-	-	-	-	-	-	
CRI(E)/CRN(E) 3-23	2.2	639	960	664	985	178	110	37	41	639	960	664	985	178	167	47	51
CRI/CRN 3-25	2.2	675	996	700	1021	178	110	37	42	-	-	-	-	-	-	-	
CRI/CRN 3-27	2.2	711	1032	736	1057	178	110	38	42	-	-	-	-	-	-	-	
CRI(E)/CRN(E) 3-29	2.2	747	1068	772	1093	178	110	39	43	747	1068	772	1093	178	167	49	54
CRI/CRN 3-31	3	788	1123	813	1148	198	120	44	48	-	-	-	-	-	-	-	
CRI/CRN 3-33	3	824	1159	849	1184	198	120	45	49	-	-	-	-	-	-	-	
CRI(E)/CRN(E) 3-36	3	878	1213	903	1238	198	120	46	50	878	1213	903	1238	198	177	56	60

CA is the code for the FlexiClamp coupling.

CRI(E) 3 pump models have a CA base up to the 3-15, suitable for use with two bolt oval flanges.

CRI(E) 3 pump models from 3-17 and above have a FGJ base for use with a four bolt DIN flange.

CRN(E) 3 models are available with either PJE of FGJ connections.

CRI(E) 3 & CRN 3 models with DIN flanges are rated DN25/32, PN25.

The recommended connection size is DN25.

CRI, CRN, CRIE, CRNE 5

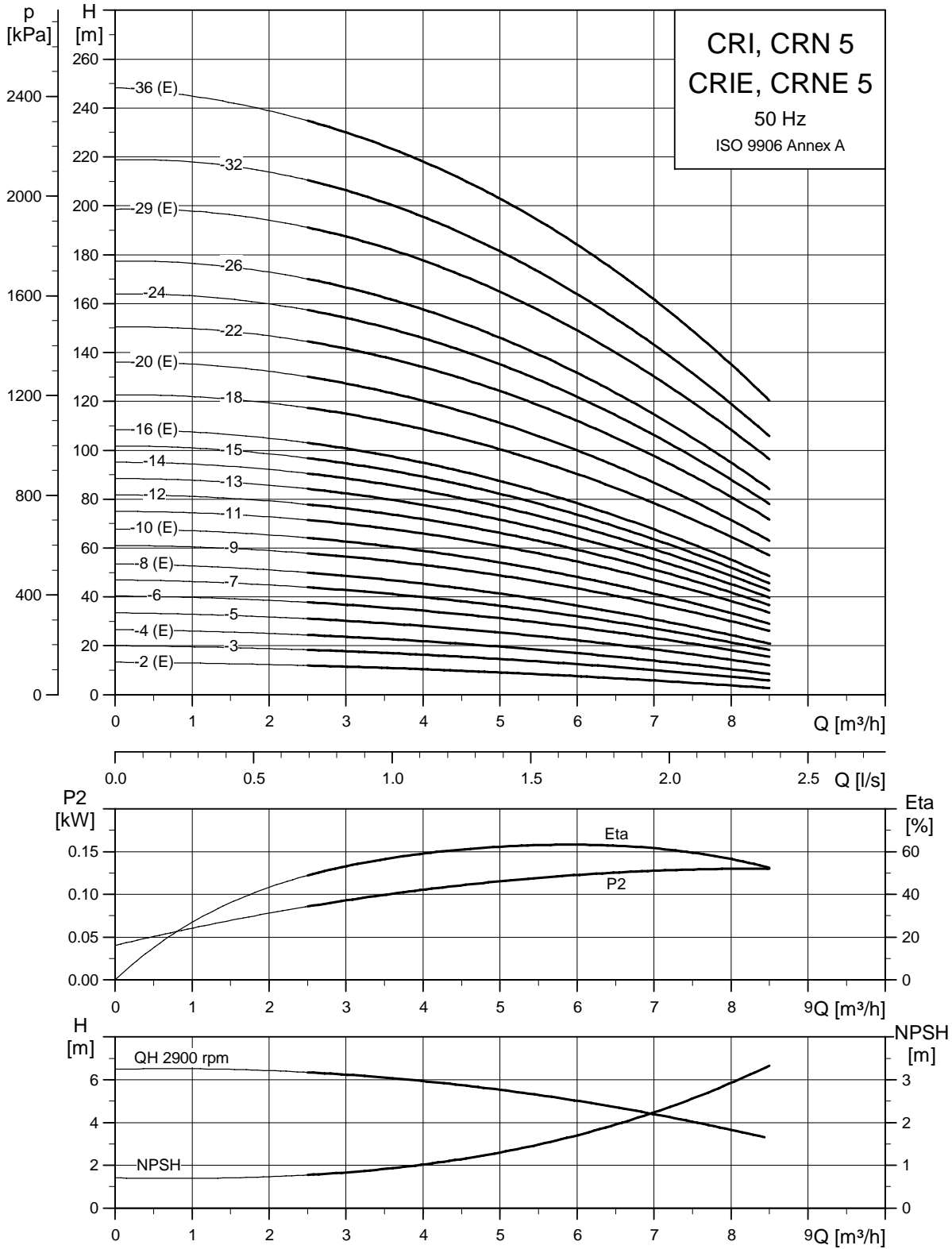

TM02 7295 3605

Dimensional sketch

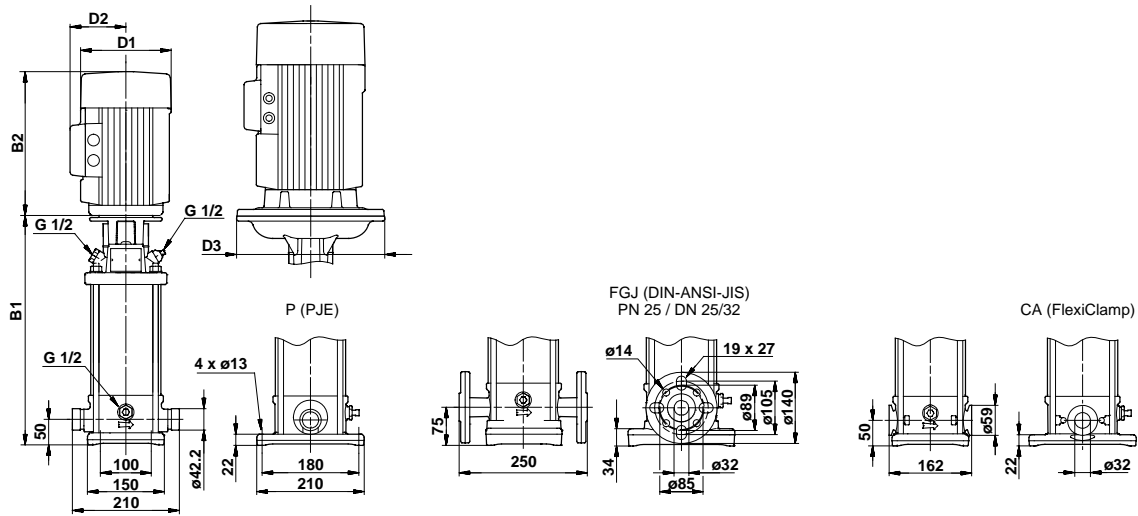

TM03 1724 2805

Dimensions and weights

Pump type	Motor P ₂ [kW]	CRI/CRN										CRIE/CRNE							
		Dimension [mm]					Net weight [kg]					Dimension [mm]					Net weight [kg]		
		PJE/CA		DIN flange			D1	D2	D3	PJE/CA	DIN flange	PJE/CA		DIN flange			PJE/CA	DIN flange	
		B1	B1+B2	B1	B1+B2	B1						B1+B2	B1	B1+B2	B1	B1+B2			D1
CRI(E)/CRN(E) 5-2	0.37	257	448	282	473	141	109	-	16	21	257	448	282	473	141	140	-	19	23
CRI/CRN 5-3	0.55	284	475	309	500	141	109	-	18	22	-	-	-	-	-	-	-	-	-
CRI(E)/CRN(E) 5-4	0.55	311	502	336	527	141	109	-	18	22	311	502	336	527	141	140	-	21	25
CRI/CRN(E) 5-5	0.75	344	575	369	600	141	109	-	21	25	344	575	369	600	178	167	-	23	27
CRI/CRN 5-6	1.1	371	602	396	627	141	109	-	24	28	-	-	-	-	-	-	-	-	-
CRI/CRN 5-7	1.1	398	629	423	654	141	109	-	24	28	-	-	-	-	-	-	-	-	-
CRI(E)/CRN(E) 5-8	1.1	425	656	450	681	141	109	-	25	29	425	656	450	681	178	167	-	27	31
CRI/CRN 5-9	1.5	468	749	493	774	178	110	-	32	36	-	-	-	-	-	-	-	-	-
CRI(E)/CRN(E) 5-10	1.5	495	776	520	801	178	110	-	32	37	495	776	520	801	178	167	-	39	43
CRI/CRN 5-11	2.2	522	843	547	868	178	110	-	34	38	-	-	-	-	-	-	-	-	-
CRI/CRN 5-12	2.2	549	870	574	895	178	110	-	34	38	-	-	-	-	-	-	-	-	-
CRI/CRN 5-13	2.2	576	897	601	922	178	110	-	35	39	-	-	-	-	-	-	-	-	-
CRI/CRN 5-14	2.2	603	924	628	949	178	110	-	35	40	-	-	-	-	-	-	-	-	-
CRI/CRN 5-15	2.2	630	951	655	976	178	110	-	36	40	-	-	-	-	-	-	-	-	-
CRI(E)/CRN(E) 5-16	2.2	657	978	682	1003	178	110	-	36	41	657	978	682	1003	178	167	-	47	51
CRI/CRN 5-18	3	716	1051	741	1076	198	120	-	42	46	-	-	-	-	-	-	-	-	-
CRI(E)/CRN(E) 5-20	3	770	1105	795	1130	198	120	-	43	47	770	1105	795	1130	198	177	-	53	57
CRI/CRN 5-22	4	824	1196	849	1221	220	134	-	55	59	-	-	-	-	-	-	-	-	-
CRI/CRN 5-24	4	878	1250	903	1275	220	134	-	56	61	-	-	-	-	-	-	-	-	-
CRI/CRN 5-26	4	932	1304	957	1329	220	134	-	58	62	-	-	-	-	-	-	-	-	-
CRI(E)/CRN(E) 5-29	4	1013	1385	1038	1410	220	134	-	59	64	1013	1385	1038	1410	220	188	-	70	74
CRI/CRN 5-32	5.5	1123	1514	1148	1539	220	134	300	75	79	-	-	-	-	-	-	-	-	-
CRI(E)/CRN(E) 5-36	5.5	1231	1622	1256	1647	220	134	300	77	81	1231	1622	1256	1647	220	188	-	84	88

CA is the code for the FlexiClamp coupling.

CRI(E) 5 pump models have a CA base up to the 5-12, suitable for use with two bolt oval flanges.

CRI(E) 5 pump models from 5-13 and above have a FGJ base for use with a four bolt DIN flange.

CRN(E) 5 models are available with either PJE of FGJ connections.

CRI(E) 5 & CRN 5 models with DIN flanges are rated DN25/32, PN25.

The recommended connection size is DN32.

CRI, CRN, CRIE, CRNE 10

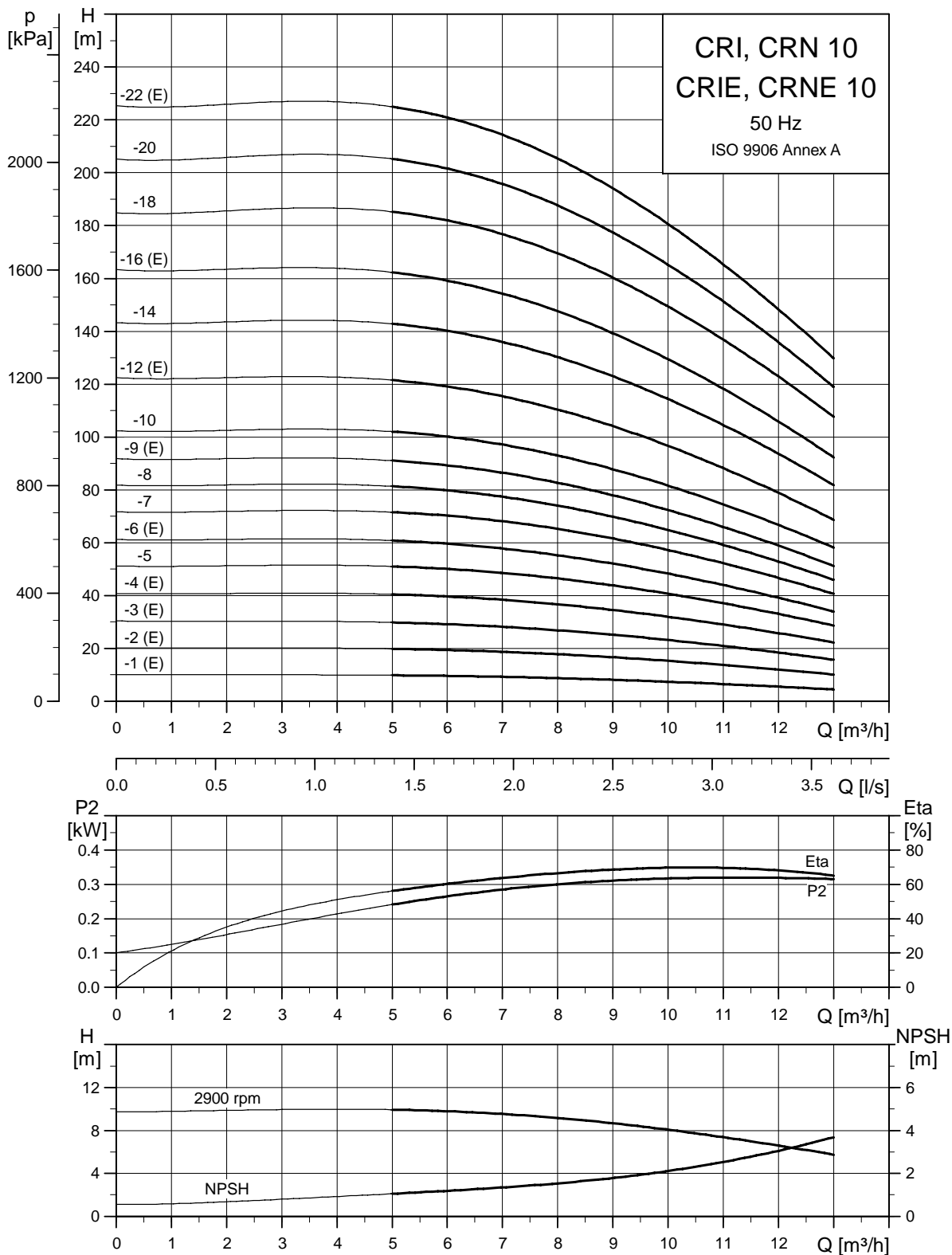

TM02 7297 3605

Dimensional sketch

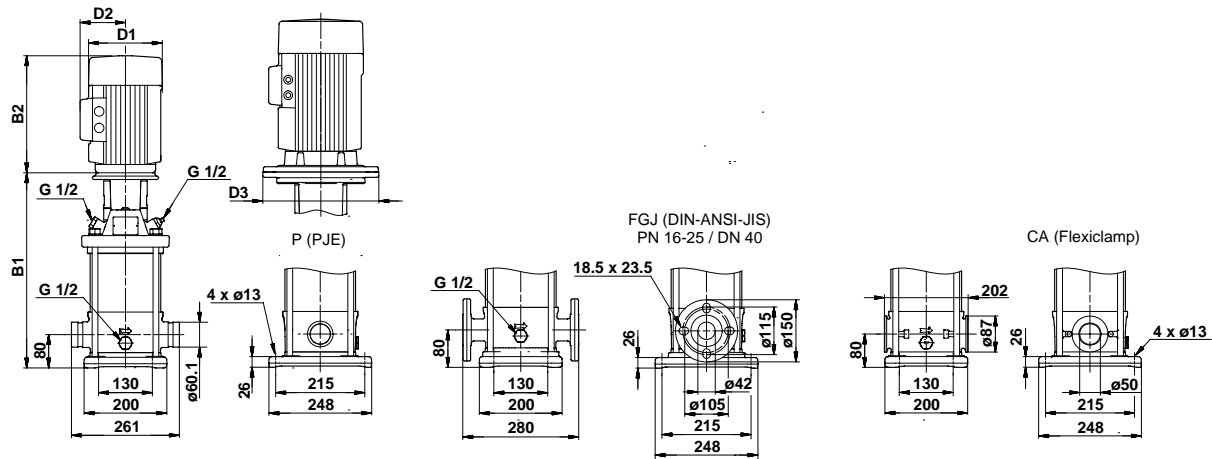

TM03 2498 4405

Dimensions and weights

Pump type	Motor P ₂ [kW]	CRI/CRN										CRIE/CRNE							
		Dimension [mm]						Net weight [kg]				Dimension [mm]						Net weight [kg]	
		PJE/CA		DIN flange		D1	D2	D3	PJE/CA	DIN flange	PJE/CA	DIN flange		D1	D2	D3	PJE/CA	DIN flange	
B1	B1+B2	B1	B1+B2				B1	B1+B2	B1	B1+B2									
CRI(E)/CRN(E) 10-1	0.37	353	544	353	544	141	109	-	28	32	353	544	353	544	141	140	-	31	35
CRI(E)/CRN(E) 10-2	0.75	357	588	357	588	141	109	-	31	34	357	588	357	588	178	167	-	33	37
CRI(E)/CRN(E) 10-3	1.1	387	618	387	618	141	109	-	34	38	387	618	387	618	178	167	-	37	40
CRI(E)/CRN(E) 10-4	1.5	433	714	433	714	178	110	-	42	46	433	714	433	714	178	167	-	49	53
CRI/CRN 10-5	2.2	463	784	463	784	178	110	-	44	48	-	-	-	-	-	-	-	-	-
CRI(E)/CRN(E) 10-6	2.2	493	814	493	814	178	110	-	45	49	493	814	493	814	178	167	-	55	59
CRI/CRN 10-7	3	528	863	528	863	198	120	-	50	54	-	-	-	-	-	-	-	-	-
CRI/CRN 10-8	3	558	893	558	893	198	120	-	52	55	-	-	-	-	-	-	-	-	-
CRI(E)/CRN(E) 10-9	3	588	923	588	923	198	120	-	53	56	588	923	588	923	198	177	-	63	66
CRI/CRN 10-10	4	618	990	618	990	220	134	-	65	68	-	-	-	-	-	-	-	-	-
CRI(E)/CRN(E) 10-12	4	678	1050	678	1050	220	134	-	67	70	678	1050	678	1050	220	188	-	77	81
CRI/CRN 10-14	5.5	770	1161	770	1161	220	134	300	89	93	-	-	-	-	-	-	-	-	-
CRI(E)/CRN(E) 10-16	5.5	830	1221	830	1221	220	134	300	91	95	830	1221	830	1221	220	188	298	98	102
CRI/CRN 10-18	7.5	890	1281	890	1281	220	134	300	96	99	-	-	-	-	-	-	-	-	-
CRI/CRN 10-20	7.5	950	1341	950	1341	220	134	300	98	101	-	-	-	-	-	-	-	-	-
CRI(E)/CRN(E) 10-22	7.5	1010	1401	1010	1401	220	134	300	100	104	1010	1401	1010	1401	220	188	298	108	111

CA is the code for the FlexiClamp coupling.

CRI(E) 10 pump models have a CA base up to the 10-9, suitable for use with two bolt oval flanges.

CRI(E) 10 pump models from 10-10 and above have a FGJ base for use with a four bolt DIN flange.

CRN(E) models are available with either PJE or FGJ connections.

CRI(E) 10 & CRN 10 models with DIN flanges are rated DN40, PN16 up to and including model 10-16, and PN25 above.

CRI, CRN, CRIE, CRNE 15

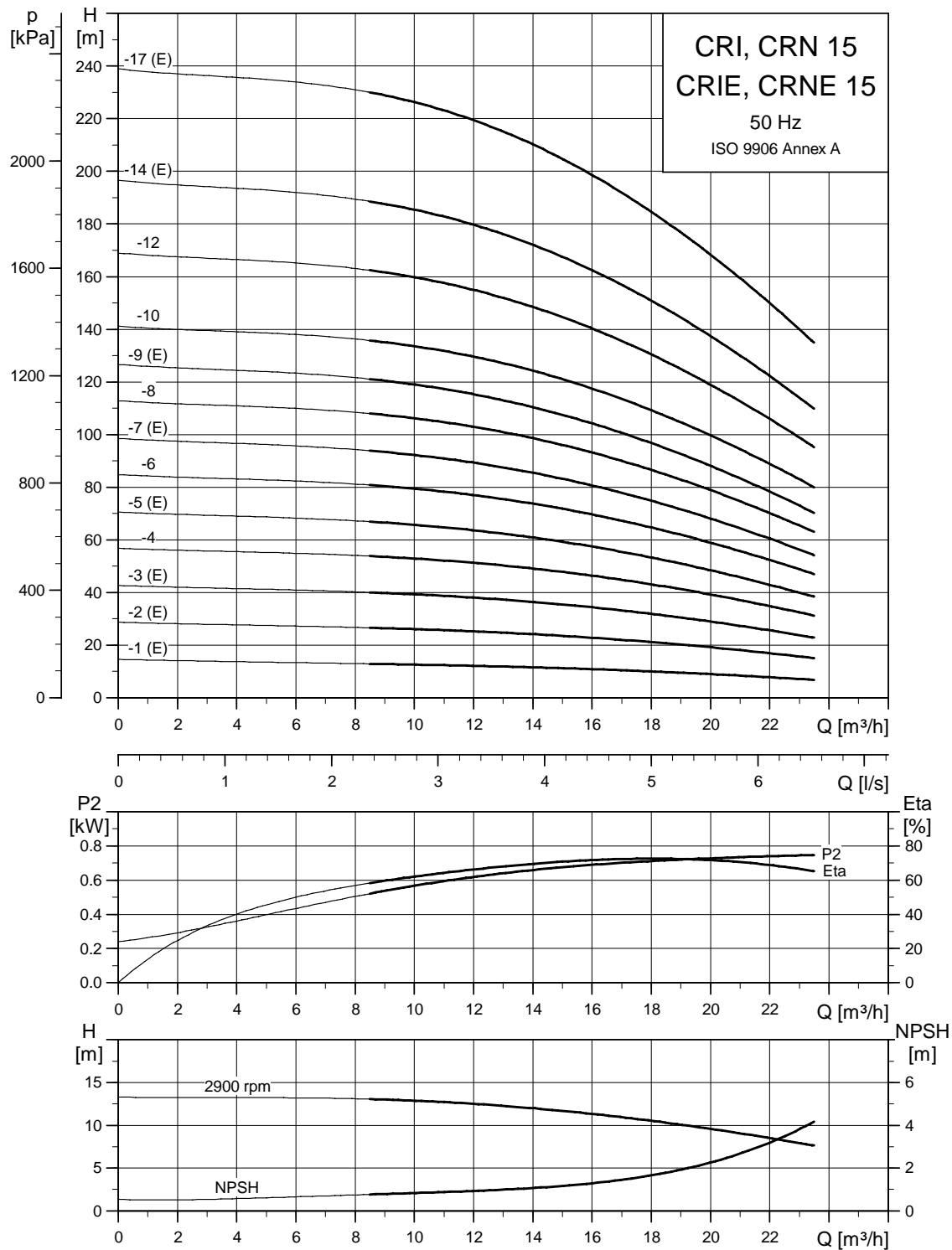

TM02.7299.3605

Dimensional sketch

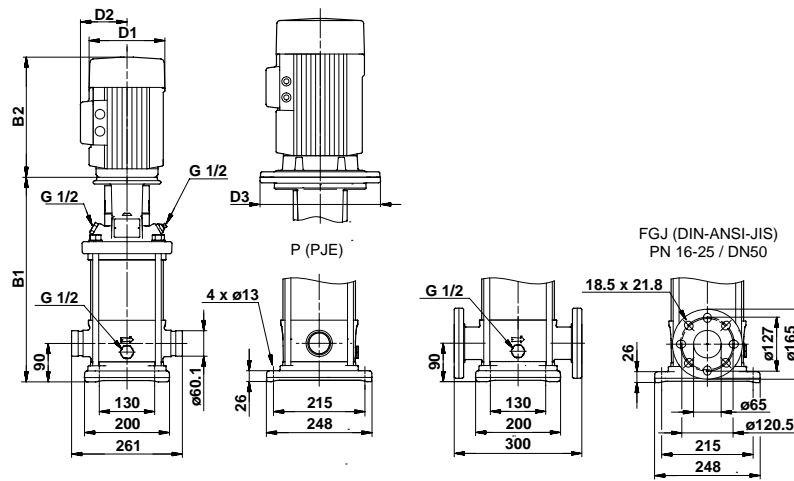

TM03 1728 2805

Dimensions and weights

Pump type	Motor P ₂ [kW]	CRI/CRN									CRIE/CRNE								
		Dimension [mm]						Net weight [kg]			Dimension [mm]						Net weight [kg]		
		PJE		DIN flange		D1	D2	D3	PJE	DIN flange	PJE		DIN flange		D1	D2	D3	PJE	DIN flange
		B1	B1+B2	B1	B1+B2						B1	B1+B2	B1	B1+B2					
CRI(E)/CRN(E) 15-1	1.1	397	628	397	628	141	109	-	34	39	397	628	397	628	178	167	-	37	42
CRI(E)/CRN(E) 15-2	2.2	413	734	413	734	178	110	-	42	47	413	734	413	734	178	167	270	53	57
CRI(E)/CRN(E) 15-3	3	463	798	463	798	198	120	-	48	53	463	798	463	798	198	177	270	58	63
CRI/CRN 15-4	4	508	880	508	880	220	134	-	61	65	-	-	-	-	-	-	-	-	-
CRI(E)/CRN(E) 15-5	4	553	925	553	925	220	134	-	62	67	553	925	553	925	220	188	270	72	77
CRI/CRN 15-6	5.5	630	1021	630	1021	220	134	300	84	89	-	-	-	-	-	-	-	-	-
CRI(E)/CRN(E) 15-7	5.5	675	1066	675	1066	220	134	300	86	90	675	1066	675	1066	220	188	298	92	97
CRI/CRN 15-8	7.5	720	1111	720	1111	220	134	300	89	94	-	-	-	-	-	-	-	-	-
CRI(E)/CRN(E) 15-9	7.5	765	1156	765	1156	220	134	300	91	96	765	1156	765	1156	220	188	298	99	104
CRI/CRN 15-10	11	887	1386	887	1386	260	172	350	123	128	-	-	-	-	-	-	-	-	-
CRI/CRN 15-12	11	977	1476	977	1476	260	172	350	126	131	-	-	-	-	-	-	-	-	-
CRI(E)/CRN(E) 15-14	11	1067	1566	1067	1566	260	172	350	130	134	1082	1531	1082	1531	258	359	350	197	202
CRI(E)/CRN(E) 15-17	15	1202	1680	1202	1680	320	197	350	149	153	1217	1678	1217	1678	313	377	350	219	224

CRI(E) 15 pump models have a FGJ base for use with a four bolt DIN flange.

CRN(E) 15 models are available with either PJE or FGJ connections.

CRI(E) 15 & CRN 15 models with DIN flanges are rated DN50, PN16 up to and including model 15-10, and PN25 above.

CRI, CRN, CRIE, CRNE 20

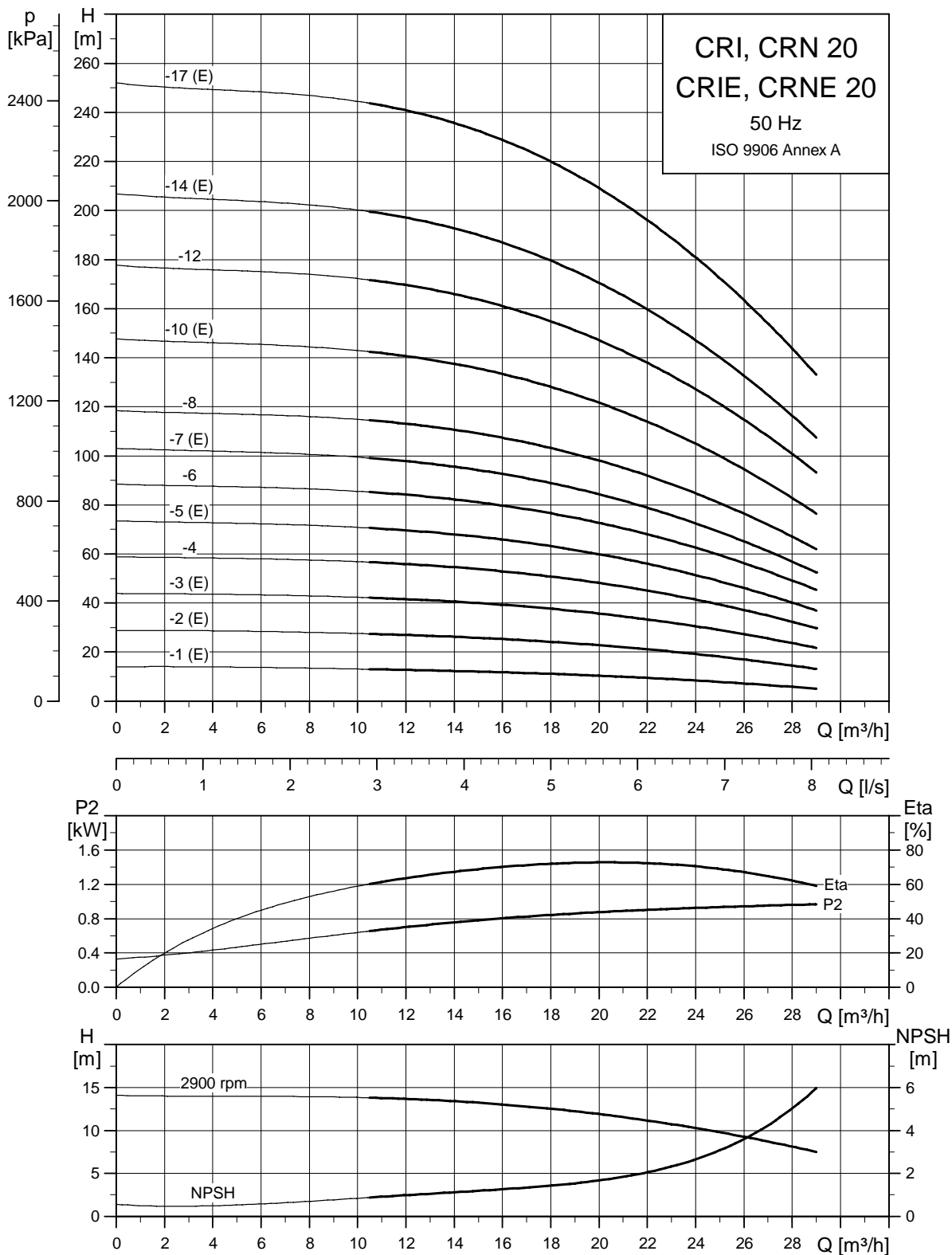

TM02 7301 3605

Dimensional sketch

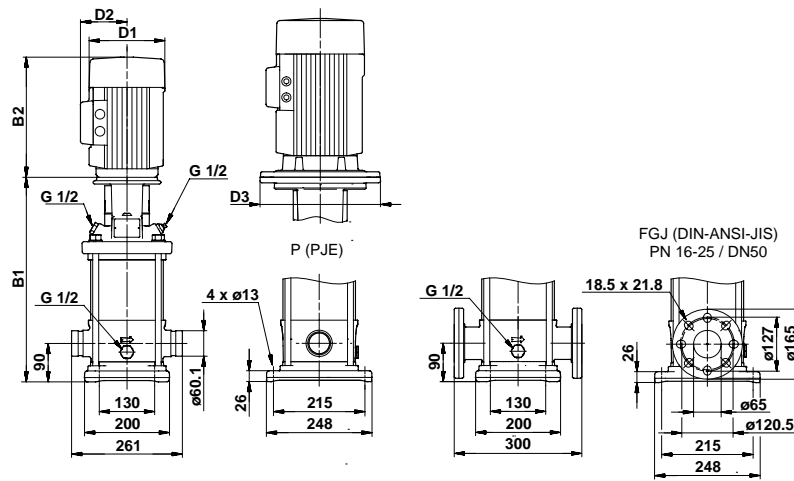

TM03 1728 2805

Dimensions and weights

Pump type	Motor P ₂ [kW]	CRI/CRN									CRIE/CRNE								
		Dimension [mm]						Net weight [kg]			Dimension [mm]						Net weight [kg]		
		PJE		DIN flange		D1	D2	D3	PJE	DIN flange	PJE		DIN flange		D1	D2	D3	PJE	DIN flange
		B1	B1+B2	B1	B1+B2						B1	B1+B2	B1	B1+B2					
CRI(E)/CRN(E) 20-1	1.1	397	628	397	628	141	109	-	34	39	397	628	397	628	178	167	-	37	42
CRI(E)/CRN(E) 20-2	2.2	413	734	413	734	178	110	-	42	47	413	734	413	734	178	167	-	53	57
CRI(E)/CRN(E) 20-3	4	463	835	463	835	220	134	-	59	64	463	835	463	835	220	188	-	69	74
CRI/CRN 20-4	5.5	540	931	540	931	220	134	300	81	86	-	-	-	-	-	-	-	-	-
CRI(E)/CRN(E) 20-5	5.5	585	976	585	976	220	134	300	82	87	585	976	585	976	220	188	298	89	94
CRI/CRN 20-6	7.5	630	1021	630	1021	220	134	300	86	91	-	-	-	-	-	-	-	-	-
CRI(E)/CRN(E) 20-7	7.5	675	1066	675	1066	220	134	300	88	92	675	1066	675	1066	220	188	298	96	100
CRI/CRN 20-8	11	797	1296	797	1296	260	172	350	119	124	-	-	-	-	-	-	-	-	-
CRI(E)/CRN(E) 20-10	11	887	1386	887	1386	260	172	350	123	128	902	1351	902	1351	258	359	350	191	195
CRI/CRN 20-12	15	977	1455	977	1455	320	197	350	140	145	-	-	-	-	-	-	-	-	-
CRI(E)/CRN(E) 20-14	15	1067	1545	1067	1545	320	197	350	144	148	1082	1543	1082	1543	313	377	350	214	219
CRI(E)/CRN(E) 20-17	18.5	1202	1720	1202	1720	320	197	350	179	183	1217	1716	1217	1716	313	377	350	254	259

CRI(E) 20 pump models have a FGJ base for use with a four bolt DIN flange.

CRN(E) 20 models are available with either PJE or FGJ connections.

CRI(E) 20 & CRN 20 models with DIN flanges are rated DN50, PN16 up to and including model 20-10, and PN25 above.

CR, CRE 32

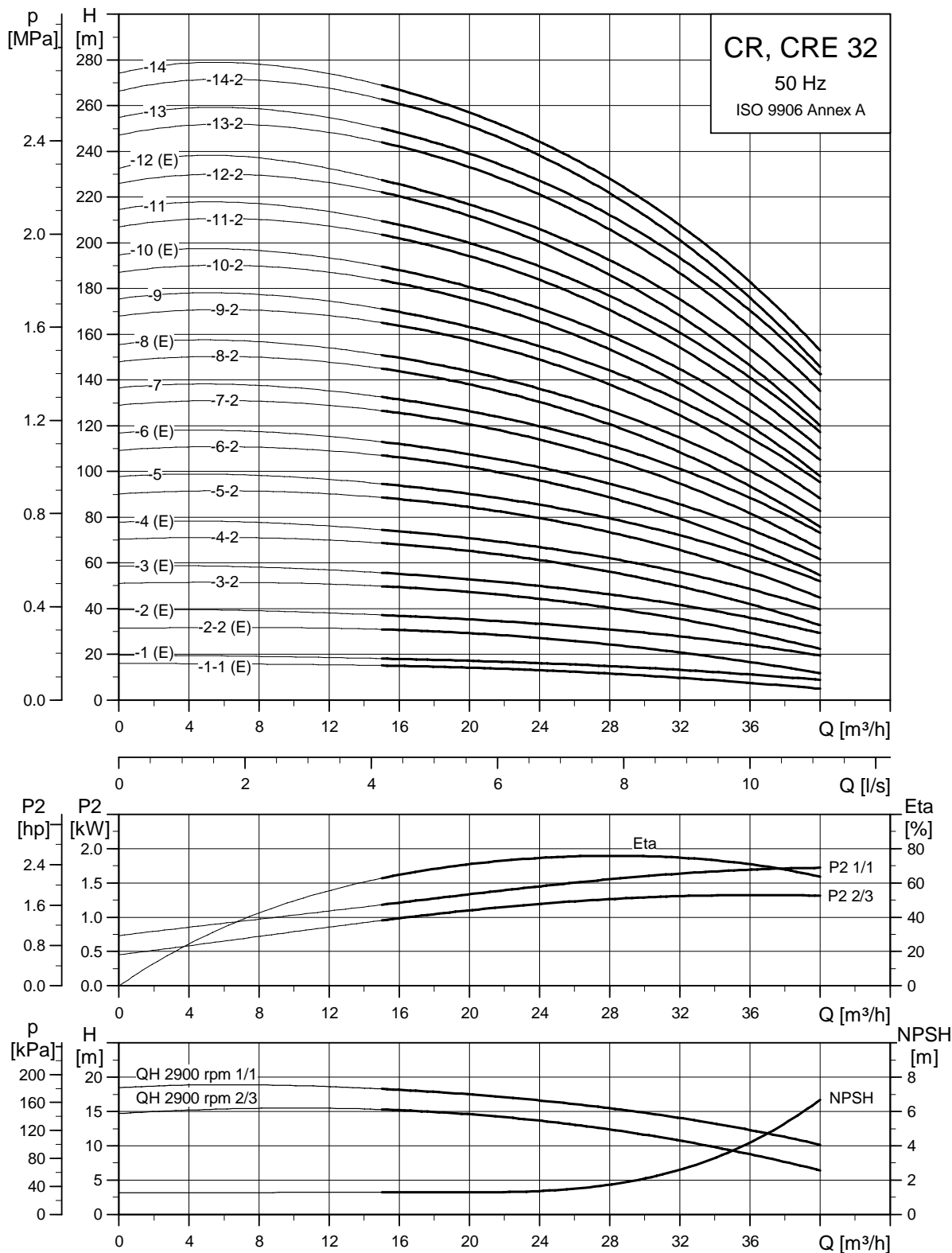

TM02 7302 3605

Dimensional sketch

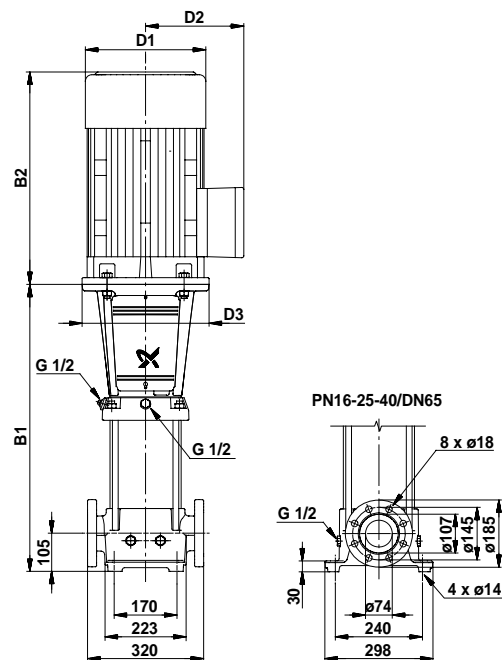

TM01 1749 3298

Dimensions and weights

Pump type	Motor P ₂ [kW]	CR					CRE						
		Dimension [mm]				Net weight [kg]	Dimension [mm]				Net weight [kg]		
		DIN flange	D1	D2	D3		DIN flange	D1	D2	D3			
CR(E) 32-1-1	1.5	505	786	178	110	270	64	505	786	178	167	270	70
CR(E) 32-1	2.2	505	826	178	110	270	64	505	826	178	167	270	74
CR(E) 32-2-2	3	575	910	198	120	270	71	575	910	198	177	270	81
CR(E) 32-2	4	575	947	220	134	270	82	575	947	220	188	270	92
CR 32-3-2	5.5	645	1036	220	134	300	96	-	-	-	-	-	-
CR(E) 32-3	5.5	645	1036	220	134	300	96	645	1036	220	188	298	103
CR 32-4-2	7.5	715	1106	220	134	300	101	-	-	-	-	-	-
CR(E) 32-4	7.5	715	1106	220	134	300	101	715	1106	220	188	298	109
CR 32-5-2	11	895	1394	260	172	350	139	-	-	-	-	-	-
CR 32-5	11	895	1394	260	172	350	139	-	-	-	-	-	-
CR 32-6-2	11	965	1464	260	172	350	142	-	-	-	-	-	-
CR(E) 32-6	11	965	1464	260	172	350	142	965	1414	258	359	350	194
CR 32-7-2	15	1035	1513	320	197	350	163	-	-	-	-	-	-
CR 32-7	15	1035	1513	320	197	350	163	-	-	-	-	-	-
CR 32-8-2	15	1105	1583	320	197	350	169	-	-	-	-	-	-
CR(E) 32-8	15	1105	1583	320	197	350	169	1105	1566	313	377	350	220
CR 32-9-2	18.5	1175	1693	320	197	350	180	-	-	-	-	-	-
CR 32-9	18.5	1175	1693	320	197	350	180	-	-	-	-	-	-
CR 32-10-2	18.5	1245	1763	320	197	350	183	-	-	-	-	-	-
CR(E) 32-10	18.5	1245	1763	320	197	350	183	1245	1744	313	377	350	262
CR 32-11-2	22	1315	1925	363	262	350	272	-	-	-	-	-	-
CR 32-11	22	1315	1925	363	262	350	272	-	-	-	-	-	-
CR 32-12-2	22	1385	1995	363	262	350	276	-	-	-	-	-	-
CR(E) 32-12	22	1385	1995	363	262	350	276	1385	1910	351	399	350	308
CR 32-13-2	30	1455	2101	415	300	400	329	-	-	-	-	-	-
CR 32-13	30	1455	2101	415	300	400	329	-	-	-	-	-	-
CR 32-14-2	30	1525	2171	415	300	400	332	-	-	-	-	-	-
CR 32-14	30	1525	2171	415	300	400	332	-	-	-	-	-	-

For information about maximum operating pressure, please see page 17.

CRN, CRNE 32

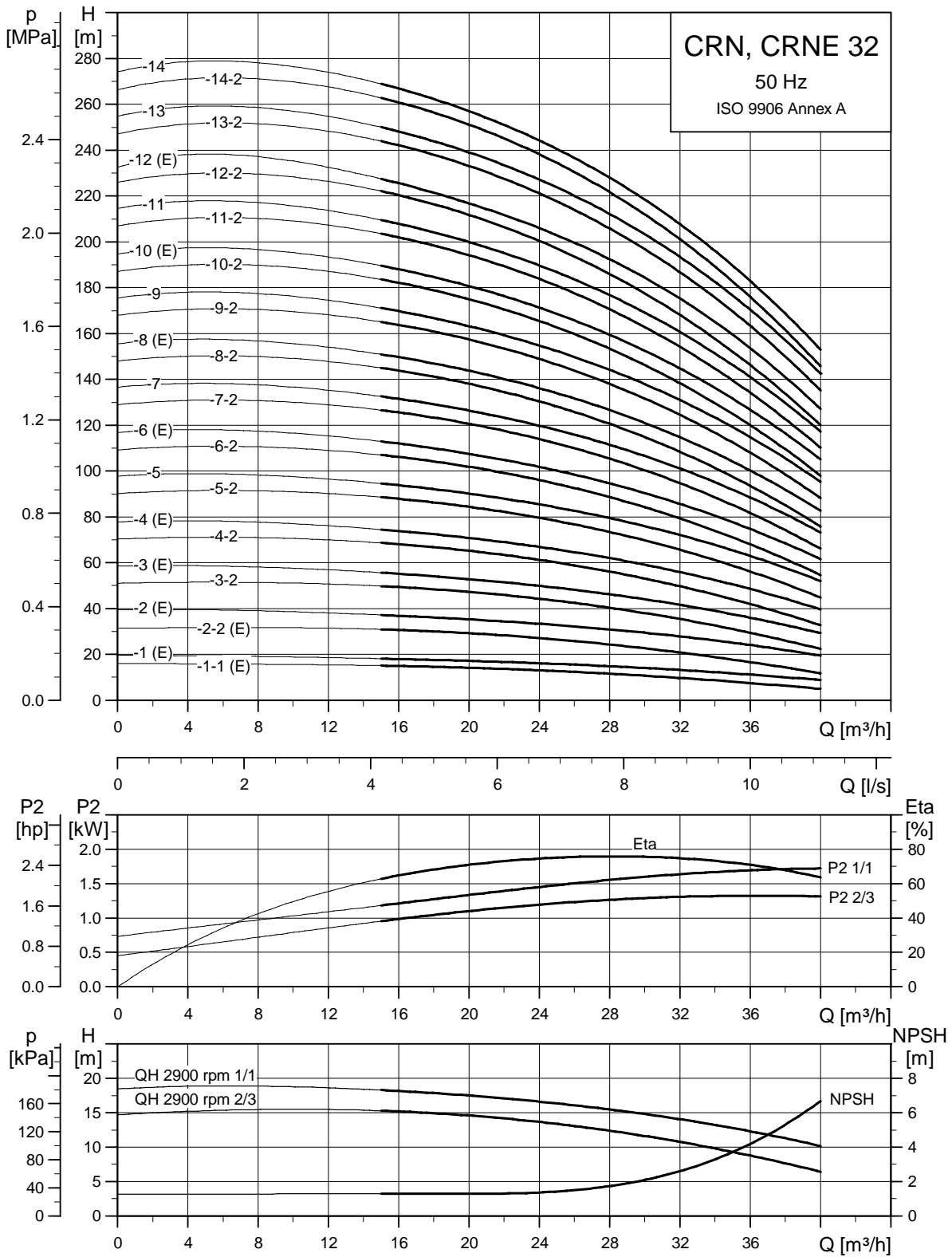

TM02 7303 3605

Dimensional sketch

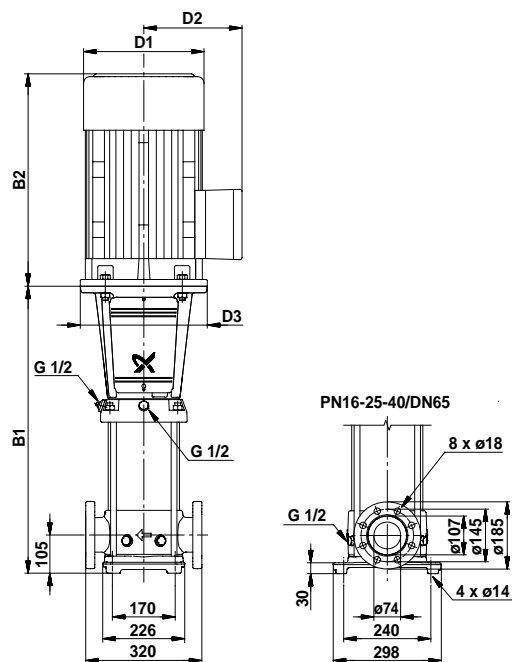

TM01 1750 2203

Dimensions and weights

Pump type	Motor P ₂ [kW]	CRN					CRNE						
		Dimension [mm]				Net weight [kg]	Dimension [mm]				Net weight [kg]		
		DIN flange	D1	D2	D3		DIN flange	D1	D2	D3			
CRN(E) 32-1-1	1.5	505	786	178	110	270	66	505	786	178	167	270	73
CRN(E) 32-1	2.2	505	826	178	110	270	66	505	826	178	167	270	77
CRN(E) 32-2-2	3	575	910	198	120	270	73	575	910	198	177	270	83
CRN(E) 32-2	4	575	947	220	134	270	84	575	947	220	188	270	94
CRN 32-3-2	5.5	645	1036	220	134	300	99	-	-	-	-	-	-
CRN(E) 32-3	5.5	645	1036	220	134	300	99	645	1036	220	188	298	105
CRN 32-4-2	7.5	715	1106	220	134	300	104	-	-	-	-	-	-
CRN(E) 32-4	7.5	715	1106	220	134	300	104	715	1106	220	188	298	111
CRN 32-5-2	11	895	1394	260	172	350	141	-	-	-	-	-	-
CRN 32-5	11	895	1394	260	172	350	141	-	-	-	-	-	-
CRN 32-6-2	11	965	1464	260	172	350	144	-	-	-	-	-	-
CRN(E) 32-6	11	965	1464	260	172	350	144	965	1414	258	359	350	196
CRN 32-7-2	15	1035	1513	320	197	350	165	-	-	-	-	-	-
CRN 32-7	15	1035	1513	320	197	350	165	-	-	-	-	-	-
CRN 32-8-2	15	1105	1583	320	197	350	171	-	-	-	-	-	-
CRN(E) 32-8	15	1105	1583	320	197	350	171	1105	1566	313	377	350	222
CRN 32-9-2	18.5	1175	1693	320	197	350	182	-	-	-	-	-	-
CRN 32-9	18.5	1175	1693	320	197	350	182	-	-	-	-	-	-
CRN 32-10-2	18.5	1245	1763	320	197	350	185	-	-	-	-	-	-
CRN(E) 32-10	18.5	1245	1763	320	197	350	185	1245	1744	313	377	350	264
CRN 32-11-2	22	1315	1925	363	262	350	274	-	-	-	-	-	-
CRN 32-11	22	1315	1925	363	262	350	274	-	-	-	-	-	-
CRN 32-12-2	22	1385	1995	363	262	350	278	-	-	-	-	-	-
CRN(E) 32-12	22	1385	1995	363	262	350	278	1385	1910	351	399	350	310
CRN 32-13-2	30	1455	2101	415	300	400	331	-	-	-	-	-	-
CRN 32-13	30	1455	2101	415	300	400	331	-	-	-	-	-	-
CRN 32-14-2	30	1525	2171	415	300	400	335	-	-	-	-	-	-
CRN 32-14	30	1525	2171	415	300	400	335	-	-	-	-	-	-

For information about maximum operating pressure, please see page 17.

CR, CRE 45

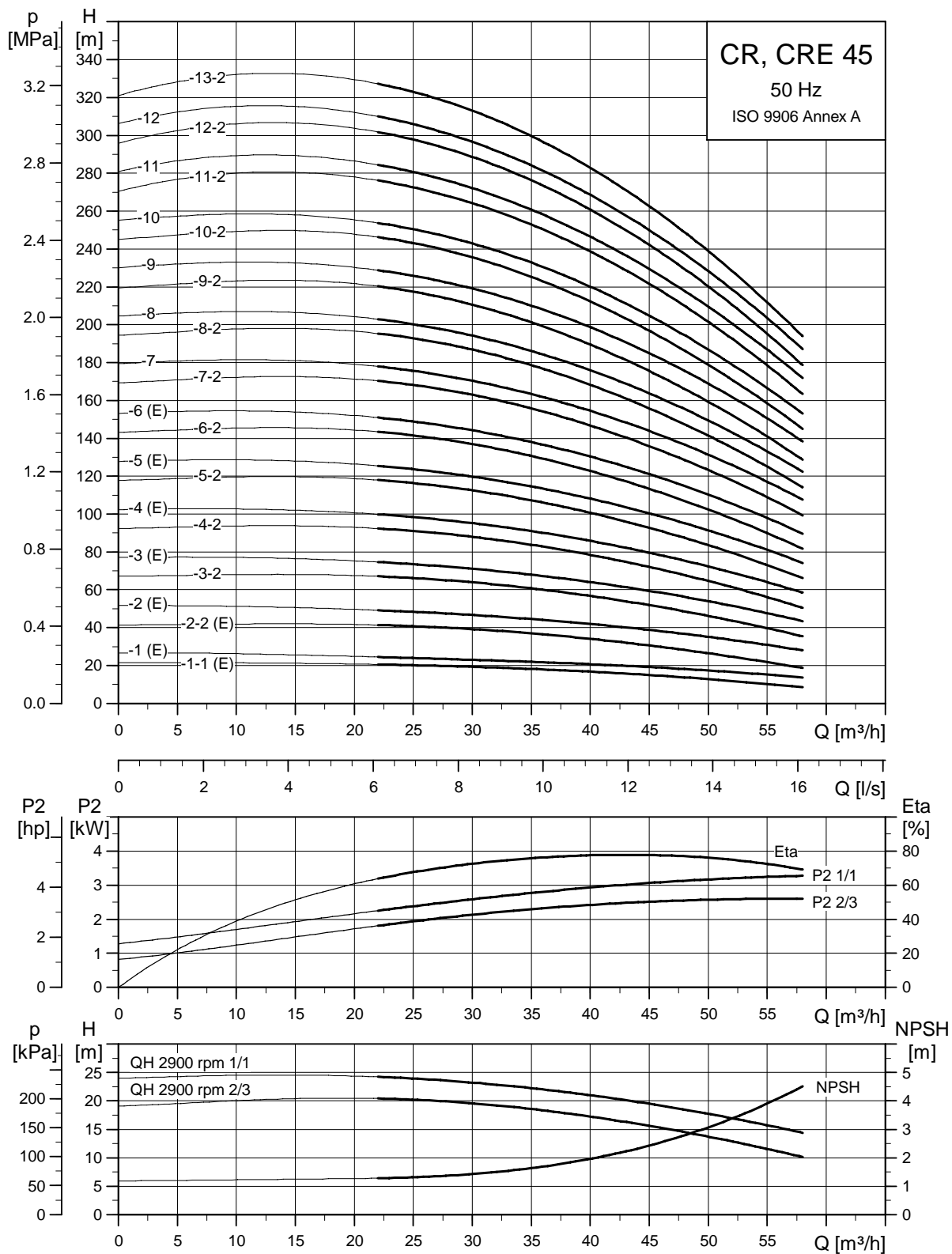

TM02 7304 3605

Dimensional sketch

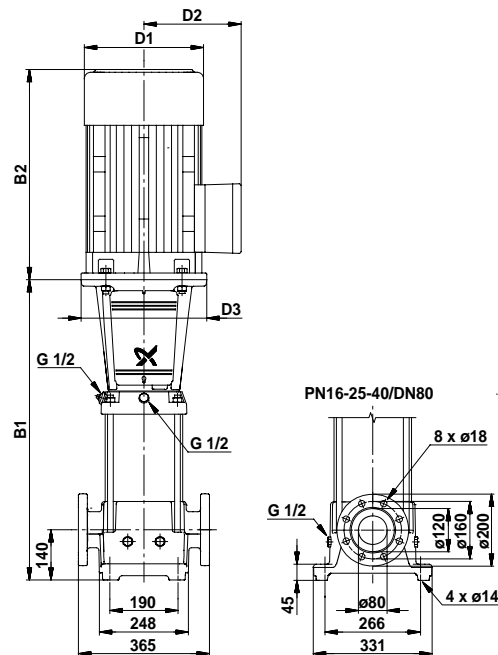

TM01 1751 3203

Dimensions and weights

Pump type	Motor P ₂ [kW]	CR					CRE						
		Dimension [mm]				Net weight [kg]	Dimension [mm]				Net weight [kg]		
		DIN flange	D1	D2	D3		DIN flange	D1	D2	D3			
CR(E) 45-1-1	3	559	894	198	120	270	78	559	894	198	177	270	88
CR(E) 45-1	4	559	931	220	134	270	89	559	931	220	188	270	99
CR(E) 45-2-2	5.5	639	1030	220	134	300	104	639	1030	220	188	298	110
CR(E) 45-2	7.5	639	1030	220	134	300	106	639	1030	220	188	298	114
CR 45-3-2	11	829	1328	260	172	350	144	-	-	-	-	-	-
CR(E) 45-3	11	829	1328	260	172	350	144	829	1278	258	359	350	196
CR 45-4-2	15	909	1387	320	197	350	166	-	-	-	-	-	-
CR(E) 45-4	15	909	1387	320	197	350	166	909	1370	313	377	350	217
CR 45-5-2	18.5	989	1507	320	197	350	177	-	-	-	-	-	-
CR(E) 45-5	18.5	989	1507	320	197	350	177	989	1488	313	377	350	256
CR 45-6-2	22	1069	1679	363	262	350	269	-	-	-	-	-	-
CR(E) 45-6	22	1069	1679	363	262	350	269	1069	1594	351	399	350	301
CR 45-7-2	30	1149	1795	415	300	400	324	-	-	-	-	-	-
CR 45-7	30	1149	1795	415	300	400	324	-	-	-	-	-	-
CR 45-8-2	30	1229	1875	415	300	400	328	-	-	-	-	-	-
CR 45-8	30	1229	1875	415	300	400	328	-	-	-	-	-	-
CR 45-9-2	30	1309	1955	415	300	400	332	-	-	-	-	-	-
CR 45-9	37	1309	2012	415	300	400	362	-	-	-	-	-	-
CR 45-10-2	37	1389	2092	415	300	400	367	-	-	-	-	-	-
CR 45-10	37	1389	2092	415	300	400	367	-	-	-	-	-	-
CR 45-11-2	45	1469	2178	442	325	450	450	-	-	-	-	-	-
CR 45-11	45	1469	2178	442	325	450	450	-	-	-	-	-	-
CR 45-12-2	45	1549	2258	442	325	450	455	-	-	-	-	-	-
CR 45-12	45	1549	2258	442	325	450	455	-	-	-	-	-	-
CR 45-13-2	45	1629	2338	442	325	450	459	-	-	-	-	-	-

For information about maximum operating pressure, please see page 17.

CRN, CRNE 45

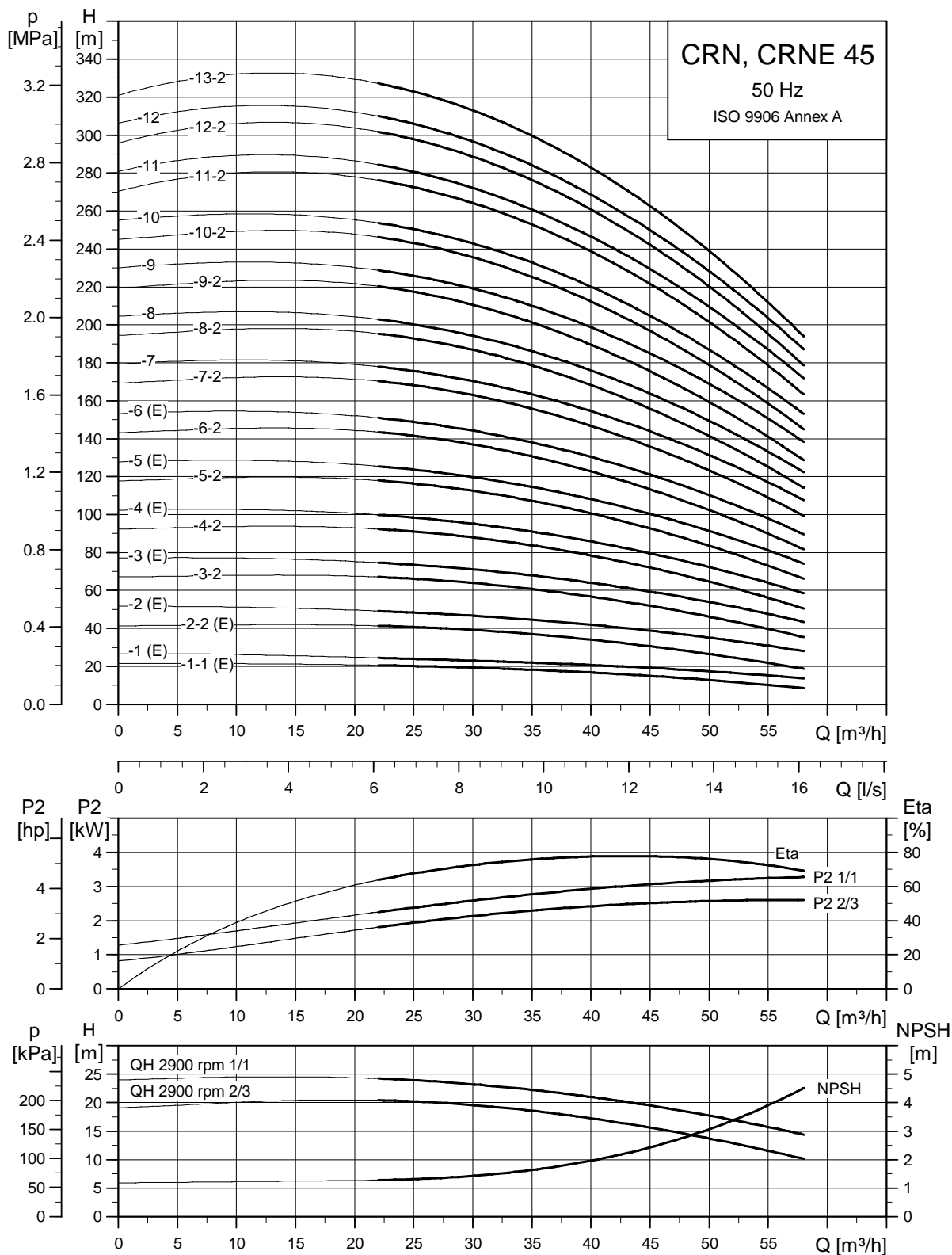

TM02 7305 3605

Dimensional sketch

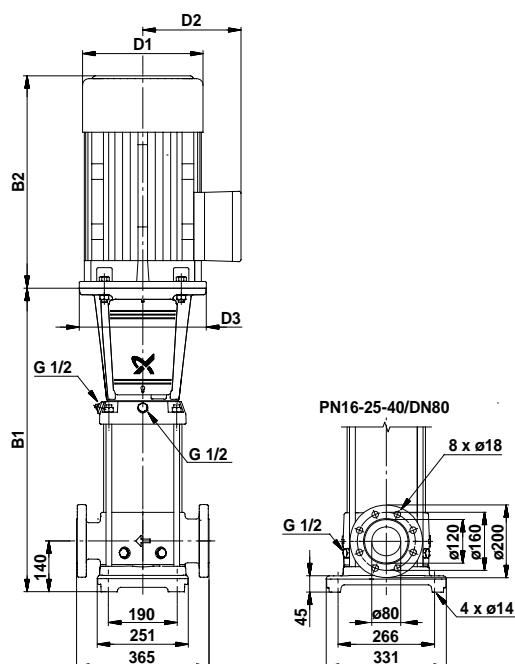

Dimensions and weights

Pump type	Motor P ₂ [kW]	CRN					CRNE						
		Dimension [mm]				Net weight [kg]	Dimension [mm]				Net weight [kg]		
		DIN flange	D1	D2	D3		DIN flange	D1	D2	D3			
CRN(E) 45-1-1	3	559	894	198	120	270	78	559	894	198	177	270	88
CRN(E) 45-1	4	559	931	220	134	270	89	559	931	220	188	270	99
CRN(E) 45-2-2	5.5	639	1030	220	134	300	104	639	1030	220	188	298	111
CRN(E) 45-2	7.5	639	1030	220	134	300	106	639	1030	220	188	298	114
CRN 45-3-2	11	829	1328	260	172	350	145	-	-	-	-	-	-
CRN(E) 45-3	11	829	1328	260	172	350	145	829	1278	258	359	350	197
CRN 45-4-2	15	909	1387	320	197	350	166	-	-	-	-	-	-
CRN(E) 45-4	15	909	1387	320	197	350	166	909	1370	313	377	350	217
CRN 45-5-2	18.5	989	1507	320	197	350	177	-	-	-	-	-	-
CRN(E) 45-5	18.5	989	1507	320	197	350	177	989	1488	313	377	350	256
CRN 45-6-2	22	1069	1679	363	262	350	270	-	-	-	-	-	-
CRN(E) 45-6	22	1069	1679	363	262	350	270	1069	1594	351	399	350	302
CRN 45-7-2	30	1149	1795	415	300	400	324	-	-	-	-	-	-
CRN 45-7	30	1149	1795	415	300	400	324	-	-	-	-	-	-
CRN 45-8-2	30	1229	1875	415	300	400	328	-	-	-	-	-	-
CRN 45-8	30	1229	1875	415	300	400	328	-	-	-	-	-	-
CRN 45-9-2	30	1309	1955	415	300	400	333	-	-	-	-	-	-
CRN 45-9	37	1309	2012	415	300	400	363	-	-	-	-	-	-
CRN 45-10-2	37	1389	2092	415	300	400	367	-	-	-	-	-	-
CRN 45-10	37	1389	2092	415	300	400	367	-	-	-	-	-	-
CRN 45-11-2	45	1469	2178	442	325	450	450	-	-	-	-	-	-
CRN 45-11	45	1469	2178	442	325	450	450	-	-	-	-	-	-
CRN 45-12-2	45	1549	2258	442	325	450	455	-	-	-	-	-	-
CRN 45-12	45	1549	2258	442	325	450	455	-	-	-	-	-	-
CRN 45-13-2	45	1629	2338	442	325	450	459	-	-	-	-	-	-

For information about maximum operating pressure, please see page 17.

TM01 1752 3203

CR, CRE 64

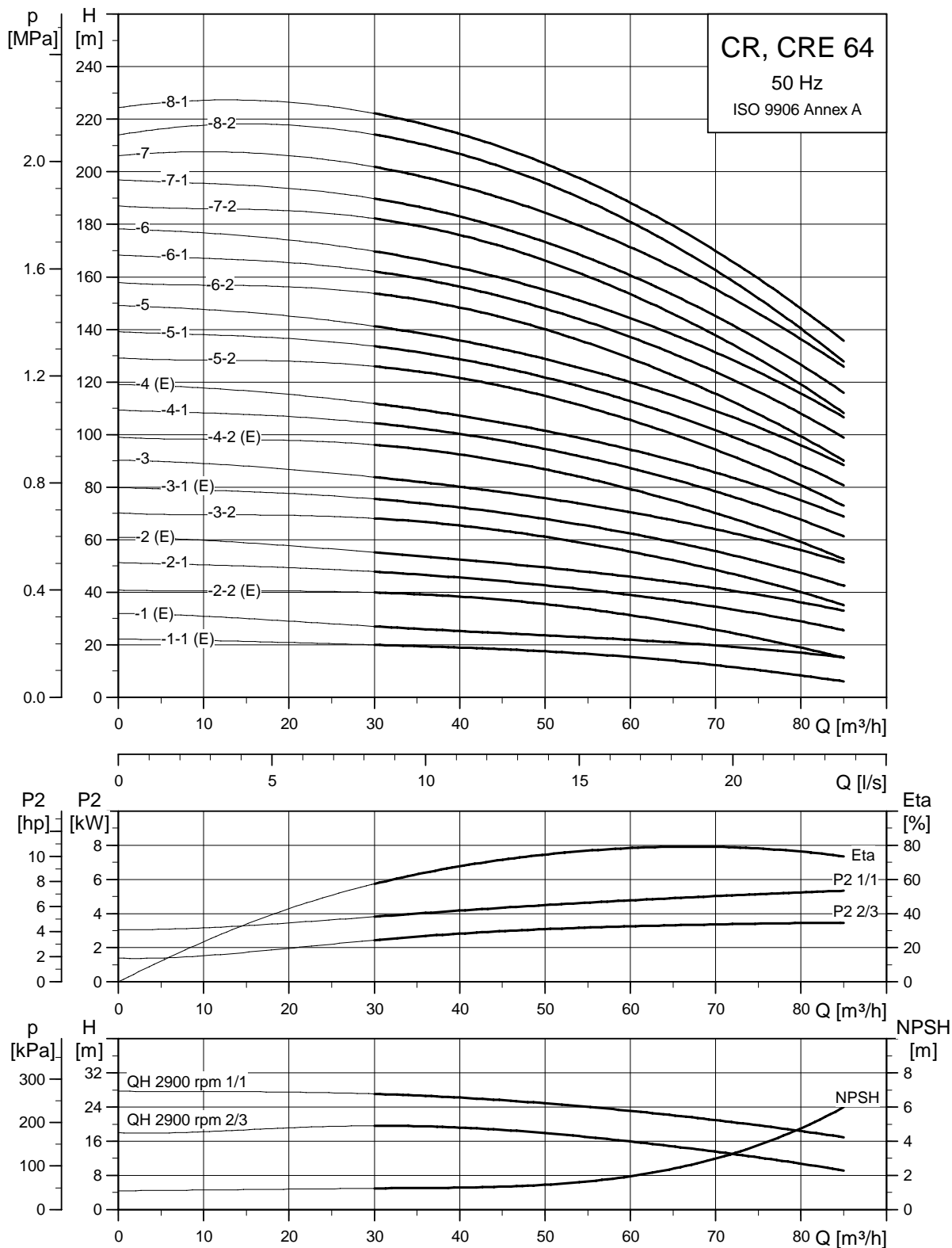

TM02 7306 3605

Dimensional sketch

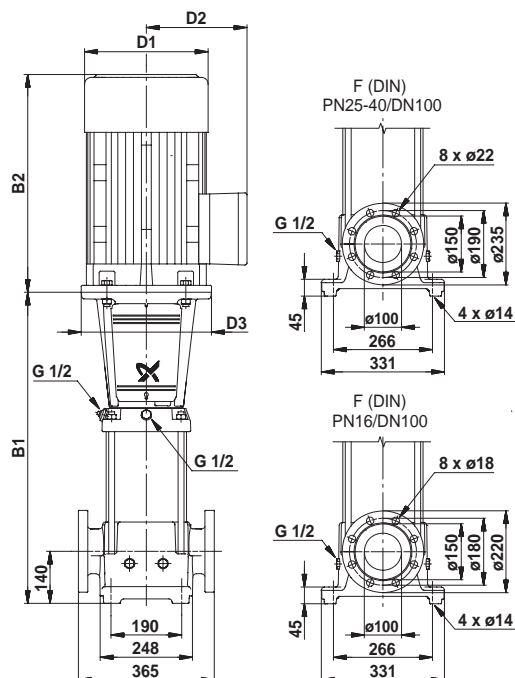

TM01 1763 5197

Dimensions and weights

Pump type	Motor P ₂ [kW]	CR					CRE						
		Dimension [mm]				Net weight [kg]	Dimension [mm]				Net weight [kg]		
		DIN flange	D1	D2	D3		DIN flange	D1	D2	D3			
CR(E) 64-1-1	4	561	933	220	134	270	91	561	933	220	188	270	101
CR(E) 64-1	5.5	561	952	220	134	300	102	561	952	220	188	298	109
CR(E) 64-2-2	7.5	644	1035	220	134	300	109	644	1035	220	188	298	117
CR 64-2-1	11	754	1253	260	172	350	143	-	-	-	-	-	-
CR(E) 64-2	11	754	1253	260	172	350	143	754	1203	258	359	350	195
CR 64-3-2	15	836	1314	320	197	350	166	-	-	-	-	-	-
CR(E) 64-3-1	15	836	1314	320	197	350	166	836	1297	313	377	350	217
CR 64-3	18.5	836	1354	320	197	350	173	-	-	-	-	-	-
CR(E) 64-4-2	18.5	919	1437	320	197	350	177	919	1418	313	377	350	256
CR 64-4-1	22	919	1529	363	262	350	263	-	-	-	-	-	-
CR(E) 64-4	22	919	1529	363	262	350	263	919	1444	351	399	350	295
CR 64-5-2	30	1001	1647	415	300	400	318	-	-	-	-	-	-
CR 64-5-1	30	1001	1647	415	300	400	318	-	-	-	-	-	-
CR 64-5	30	1001	1647	415	300	400	318	-	-	-	-	-	-
CR 64-6-2	30	1084	1730	415	300	400	324	-	-	-	-	-	-
CR 64-6-1	37	1084	1787	415	300	400	354	-	-	-	-	-	-
CR 64-6	37	1084	1787	415	300	400	354	-	-	-	-	-	-
CR 64-7-2	37	1166	1869	415	300	400	359	-	-	-	-	-	-
CR 64-7-1	37	1166	1869	415	300	400	359	-	-	-	-	-	-
CR 64-7	45	1166	1875	442	325	450	438	-	-	-	-	-	-
CR 64-8-2	45	1249	1958	442	325	450	443	-	-	-	-	-	-
CR 64-8-1	45	1249	1958	442	325	450	443	-	-	-	-	-	-

For information about maximum operating pressure, please see page 17.

CRN, CRNE 64

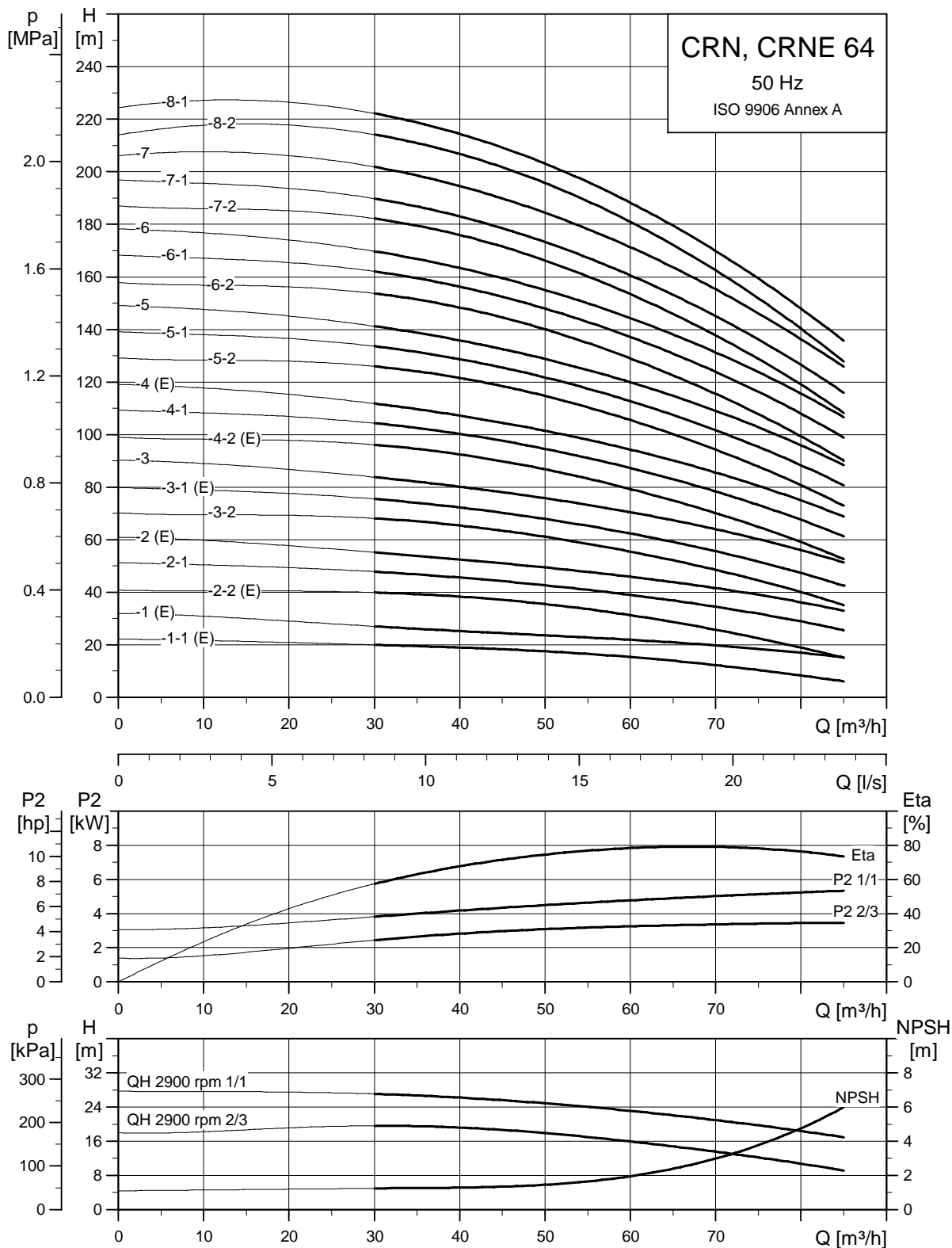

TM02 7307 3605

Dimensional sketch

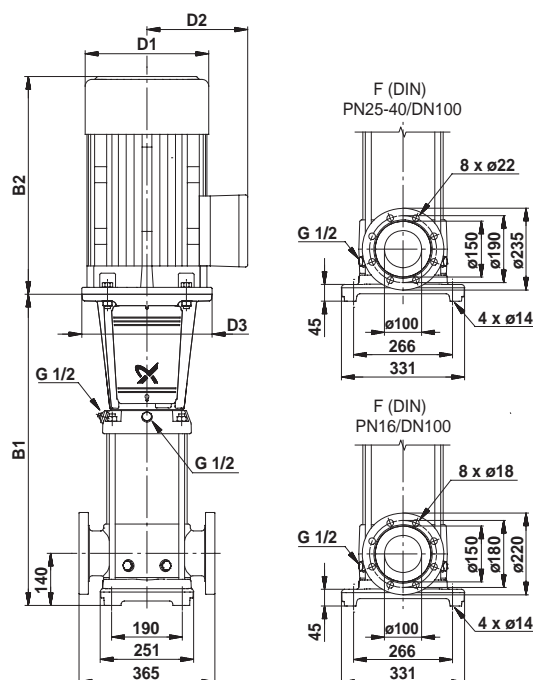

TM01 1754 0904

Dimensions and weights

Pump type	Motor P ₂ [kW]	CRN						CRNE					
		Dimension [mm]					Net weight [kg]	Dimension [mm]					Net weight [kg]
		DIN flange	D1	D2	D3	D3		DIN flange	D1	D2	D3	D3	
CRN(E) 64-1-1	4	561	933	220	134	270	91	561	933	220	188	270	101
CRN(E) 64-1	5.5	561	952	220	134	300	102	561	952	220	188	298	109
CRN(E) 64-2-2	7.5	644	1035	220	134	300	109	644	1035	220	188	298	116
CRN 64-2-1	11	754	1253	260	172	350	143	-	-	-	-	-	-
CRN(E) 64-2	11	754	1253	260	172	350	143	754	1203	258	359	350	195
CRN 64-3-2	15	836	1314	320	197	350	166	-	-	-	-	-	-
CRN(E) 64-3-1	15	836	1314	320	197	350	166	836	1297	313	377	350	217
CRN 64-3	18.5	836	1354	320	197	350	173	-	-	-	-	-	-
CRN(E) 64-4-2	18.5	919	1437	320	197	350	177	919	1418	313	377	350	256
CRN 64-4-1	22	919	1529	363	262	350	263	-	-	-	-	-	-
CRN(E) 64-4	22	919	1529	363	262	350	263	919	1444	351	399	350	295
CRN 64-5-2	30	1001	1647	415	300	400	318	-	-	-	-	-	-
CRN 64-5-1	30	1001	1647	415	300	400	318	-	-	-	-	-	-
CRN 64-5	30	1001	1647	415	300	400	318	-	-	-	-	-	-
CRN 64-6-2	30	1084	1730	415	300	400	325	-	-	-	-	-	-
CRN 64-6-1	37	1084	1787	415	300	400	355	-	-	-	-	-	-
CRN 64-6	37	1084	1787	415	300	400	355	-	-	-	-	-	-
CRN 64-7-2	37	1166	1869	415	300	400	359	-	-	-	-	-	-
CRN 64-7-1	37	1166	1869	415	300	400	359	-	-	-	-	-	-
CRN 64-7	45	1166	1875	442	325	450	439	-	-	-	-	-	-
CRN 64-8-2	45	1249	1958	442	325	450	443	-	-	-	-	-	-
CRN 64-8-1	45	1249	1958	442	325	450	443	-	-	-	-	-	-

For information about maximum operating pressure, please see page 17.

CR, CRE 90

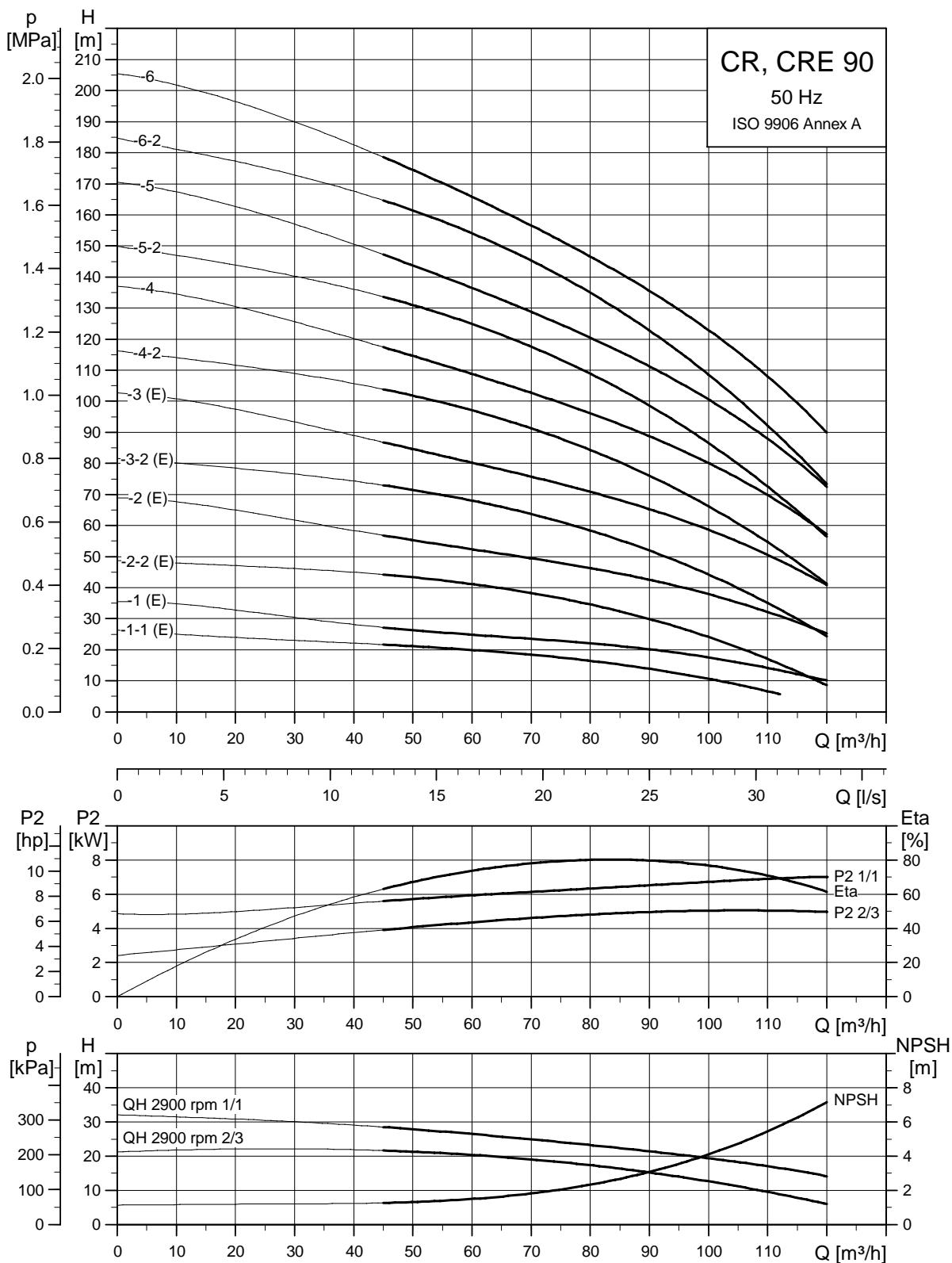

TM02 7308 3605

Dimensional sketch

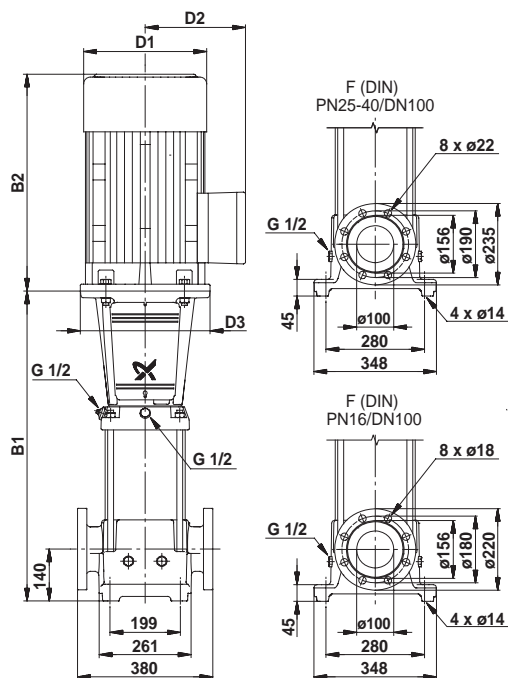

TM01 1765 2203

Dimensions and weights

Pump type	Motor P ₂ [kW]	CR					CRE						
		Dimension [mm]				Net weight [kg]	Dimension [mm]				Net weight [kg]		
		DIN flange	D1	D2	D3		DIN flange	D1	D2	D3			
CR(E) 90-1-1	5.5	571	962	220	134	300	107	571	962	220	188	298	114
CR(E) 90-1	7.5	571	962	220	134	300	109	571	962	220	188	298	117
CR(E) 90-2-2	11	773	1272	260	172	350	149	773	1222	258	359	350	201
CR(E) 90-2	15	773	1251	320	197	350	167	773	1234	313	377	350	218
CR(E) 90-3-2	18.5	865	1383	320	197	350	179	865	1364	313	377	350	258
CR(E) 90-3	22	865	1475	363	262	350	264	865	1390	351	399	350	296
CR 90-4-2	30	957	1603	415	300	400	320	-	-	-	-	-	-
CR 90-4	30	957	1603	415	300	400	320	-	-	-	-	-	-
CR 90-5-2	37	1049	1752	415	300	400	356	-	-	-	-	-	-
CR 90-5	37	1049	1752	415	300	400	356	-	-	-	-	-	-
CR 90-6-2	45	1141	1850	442	325	450	441	-	-	-	-	-	-
CR 90-6	45	1141	1850	442	325	450	441	-	-	-	-	-	-

For information about maximum operating pressure, please see page 17.

CRN, CRNE 90

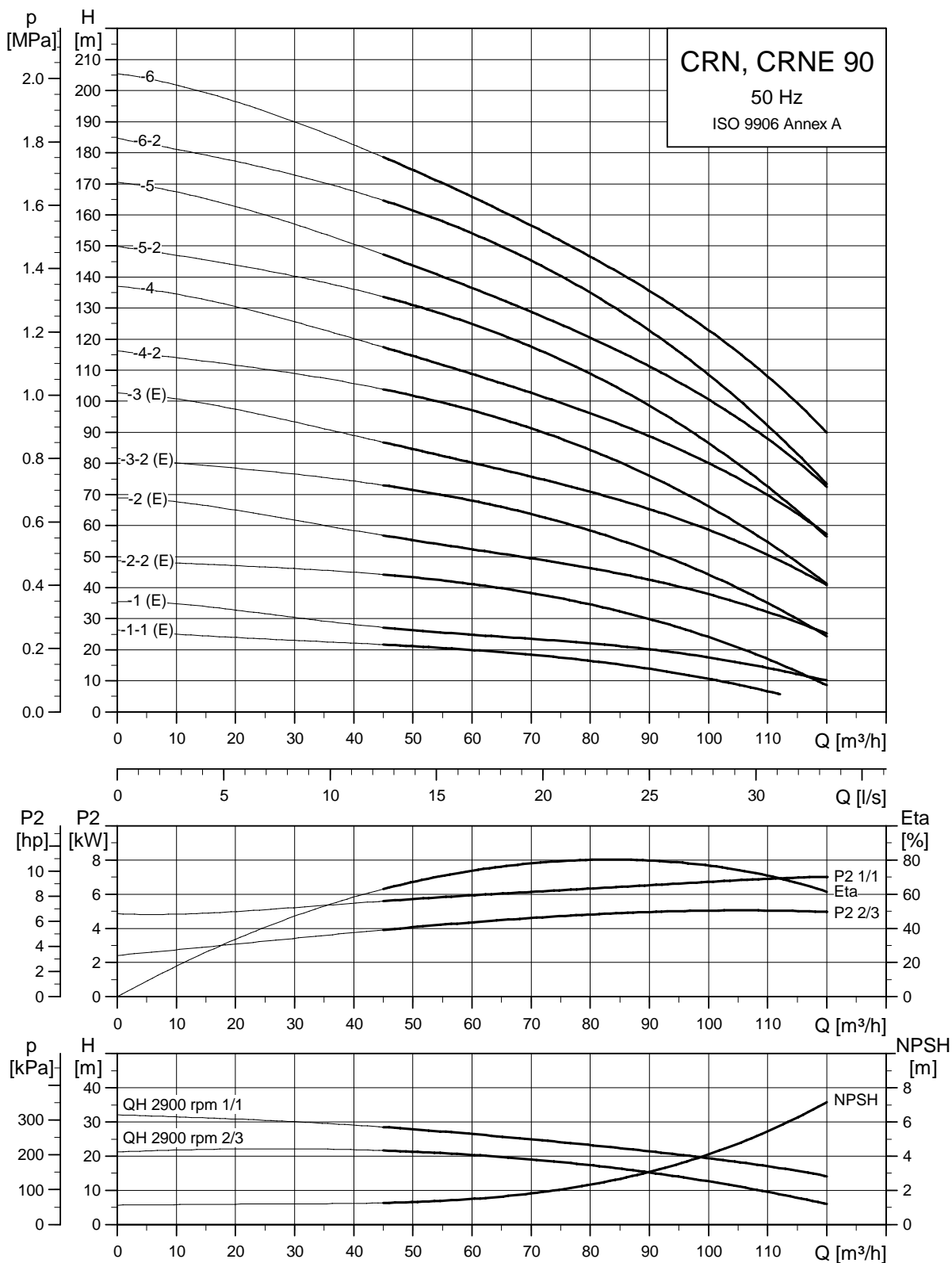

TM02 7309 3605

Dimensional sketch

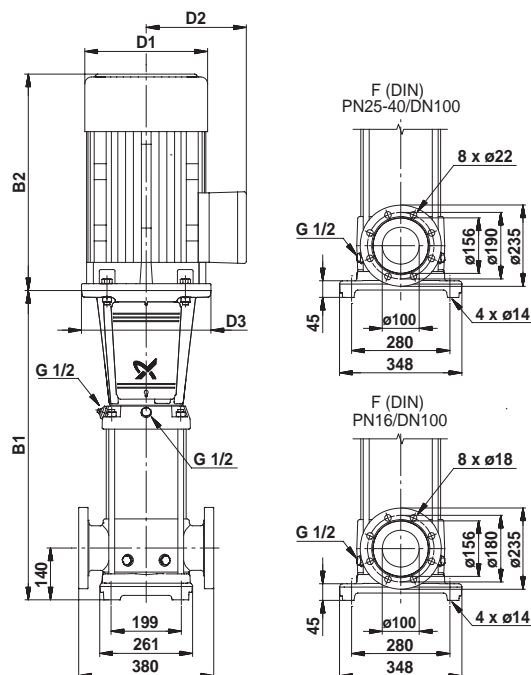

TM02 1570 2203

Dimensions and weights

Pump type	Motor P ₂ [kW]	CRN						CRNE					
		Dimension [mm]					Net weight [kg]	Dimension [mm]					Net weight [kg]
		DIN flange	D1	D2	D3	D3		DIN flange	D1	D2	D3	D3	
CRN(E) 90-1-1	5.5	571	962	220	134	300	109	571	962	220	188	298	115
CRN(E) 90-1	7.5	571	962	220	134	300	111	571	962	220	188	298	118
CRN(E) 90-2-2	11	773	1272	260	172	350	150	773	1222	258	359	350	202
CRN(E) 90-2	15	773	1251	320	197	350	168	773	1234	313	377	350	219
CRN(E) 90-3-2	18.5	865	1383	320	197	350	180	865	1364	313	377	350	259
CRN(E) 90-3	22	865	1475	363	262	350	266	865	1390	351	399	350	298
CRN 90-4-2	30	957	1603	415	300	400	321	-	-	-	-	-	-
CRN 90-4	30	957	1603	415	300	400	321	-	-	-	-	-	-
CRN 90-5-2	37	1049	1752	415	300	400	359	-	-	-	-	-	-
CRN 90-5	37	1049	1752	415	300	400	359	-	-	-	-	-	-
CRN 90-6-2	45	1141	1850	442	325	450	443	-	-	-	-	-	-
CRN 90-6	45	1141	1850	442	325	450	443	-	-	-	-	-	-

For information about maximum operating pressure, please see page 17.

CR 120

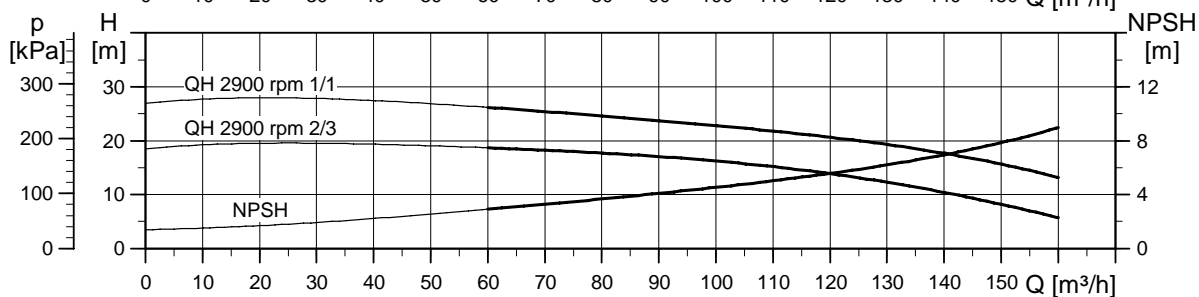
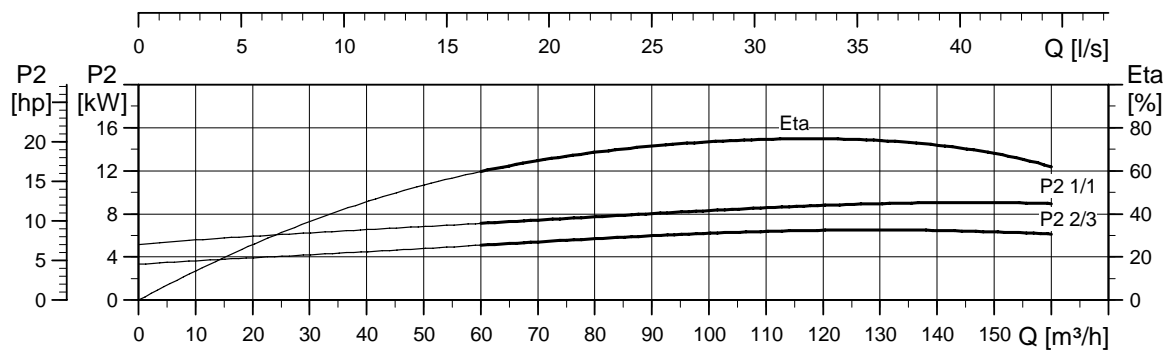
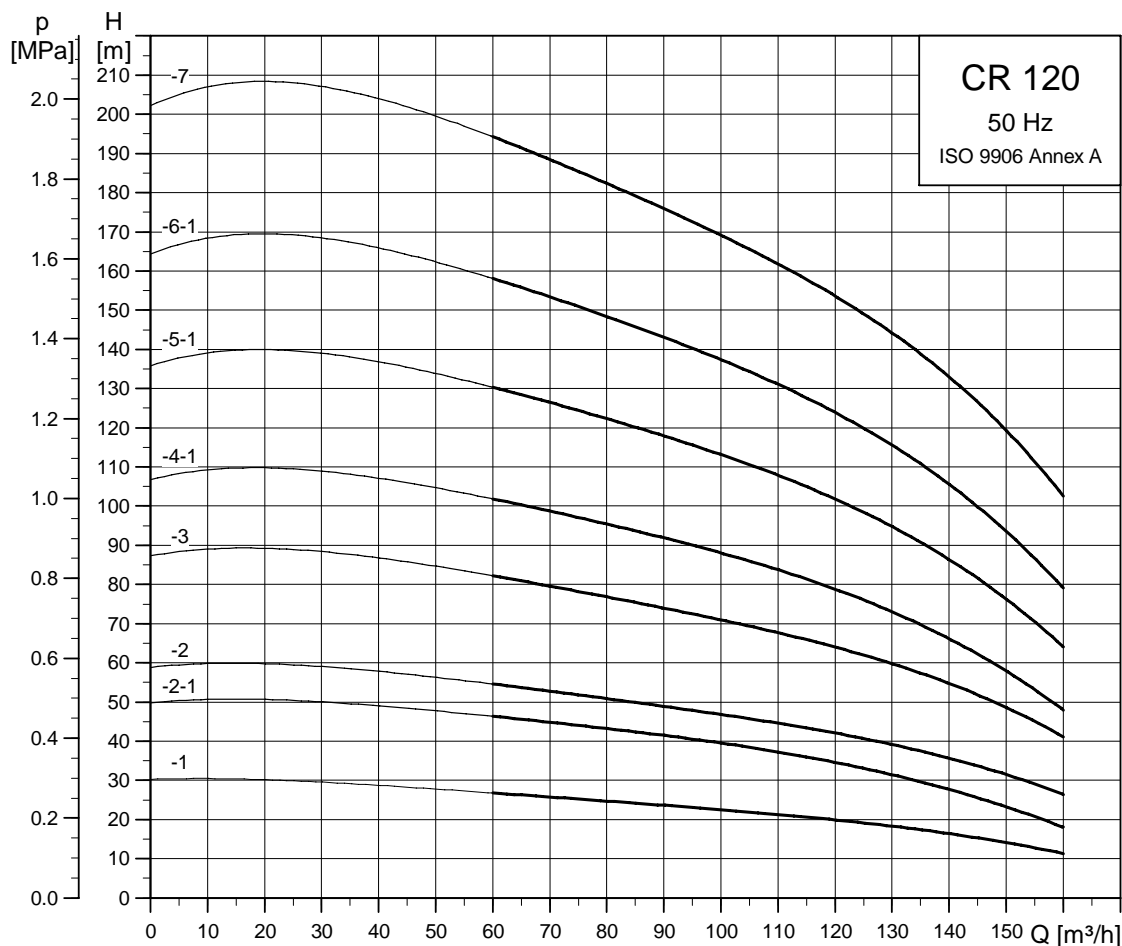

TM03 8743 2407

Dimensional sketch

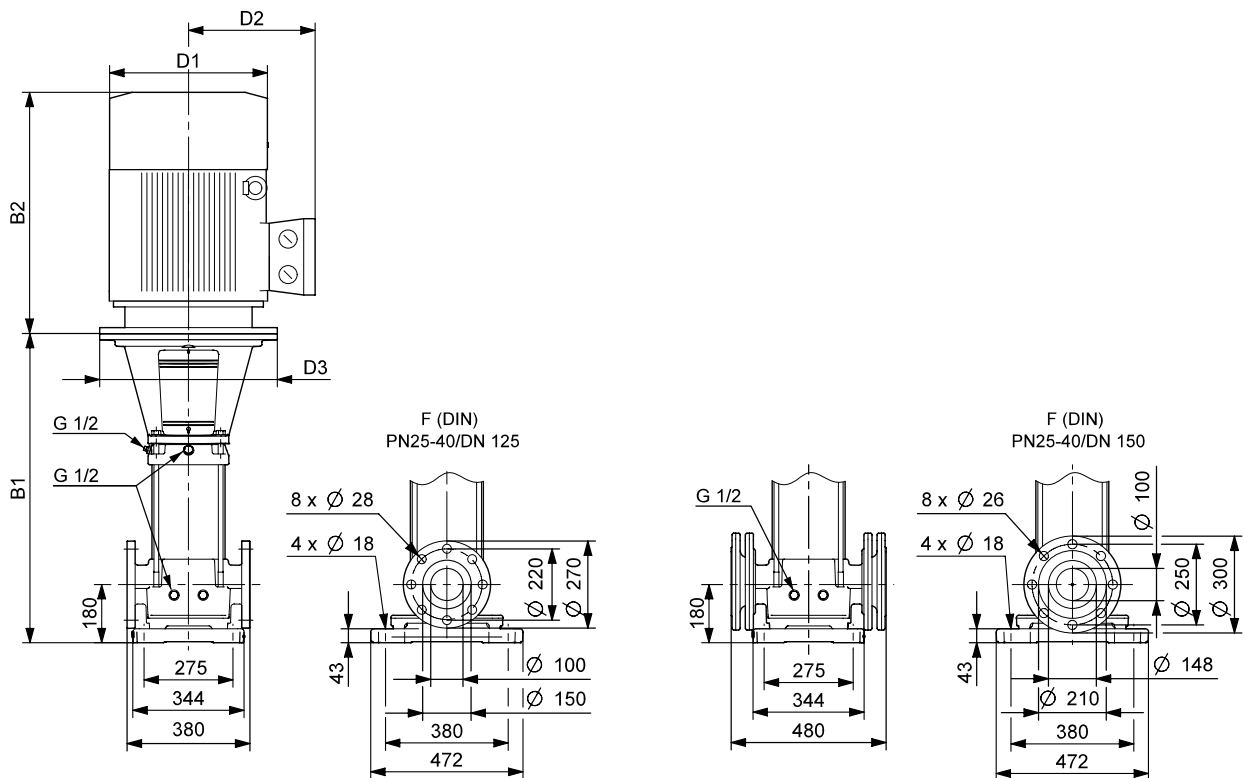

TM03 5999 4106

Dimensions and weights

Pump type	Motor P ₂ [kW]	Dimension [mm]					Net weight [kg]
		B1	B1+B2	D1	D2	D3	
CR 120-1	11	834	1333	260	172	350	172
CR 120-2-1	18.5	990	1508	320	197	350	207
CR 120-2	22	990	1600	363	262	350	293
CR 120-3	30	1145	1791	415	300	400	353
CR 120-4-1	37	1301	2004	415	300	400	392
CR 120-5-1	45	1456	2165	442	325	450	482
CR 120-6-1	55	1642	2389	495	392	550	627
CR 120-7	75	1797	2617	555	432	550	771

For information about maximum operating pressure, please see page 17.

CRN 120

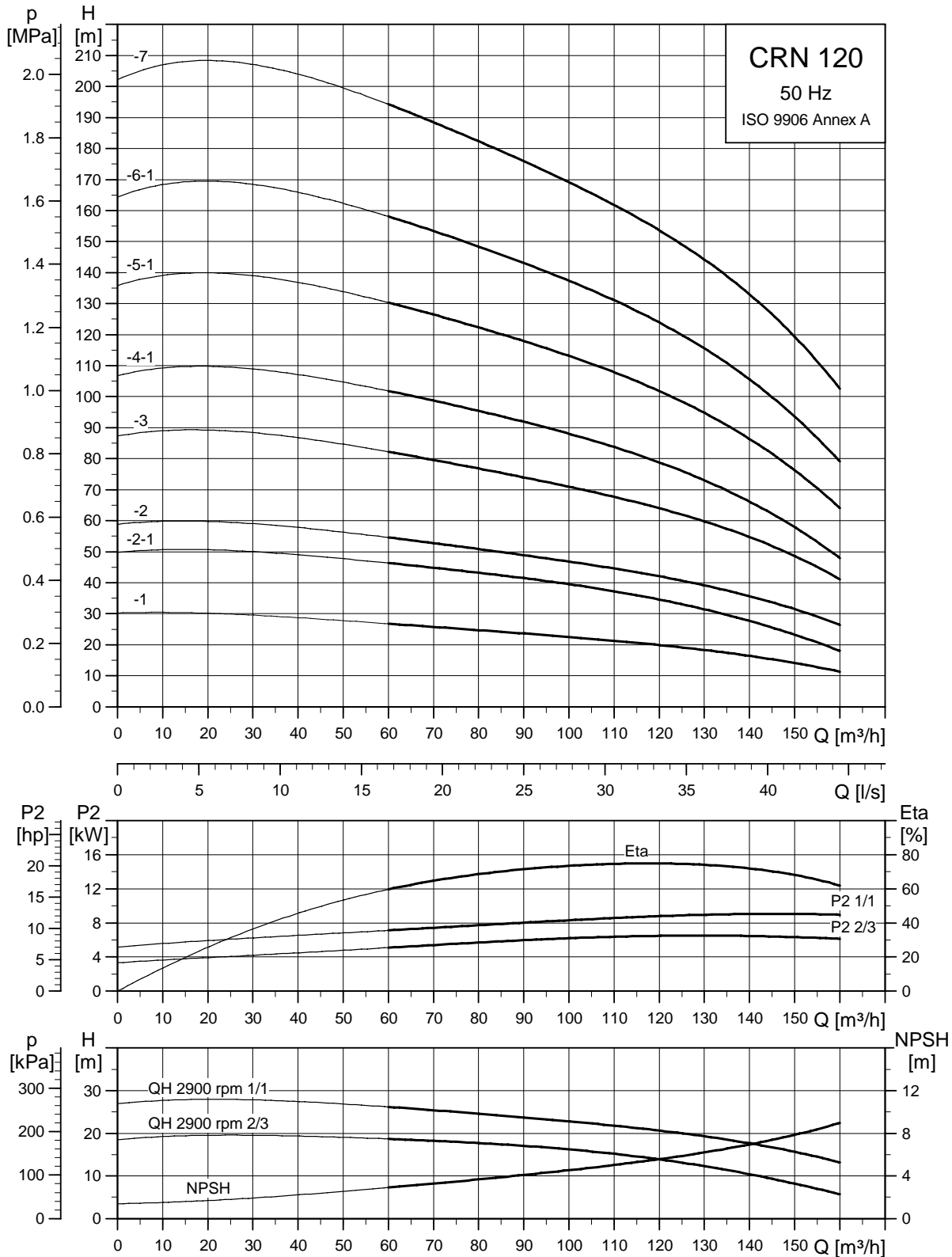

TM03 8744 2407

Dimensional sketch

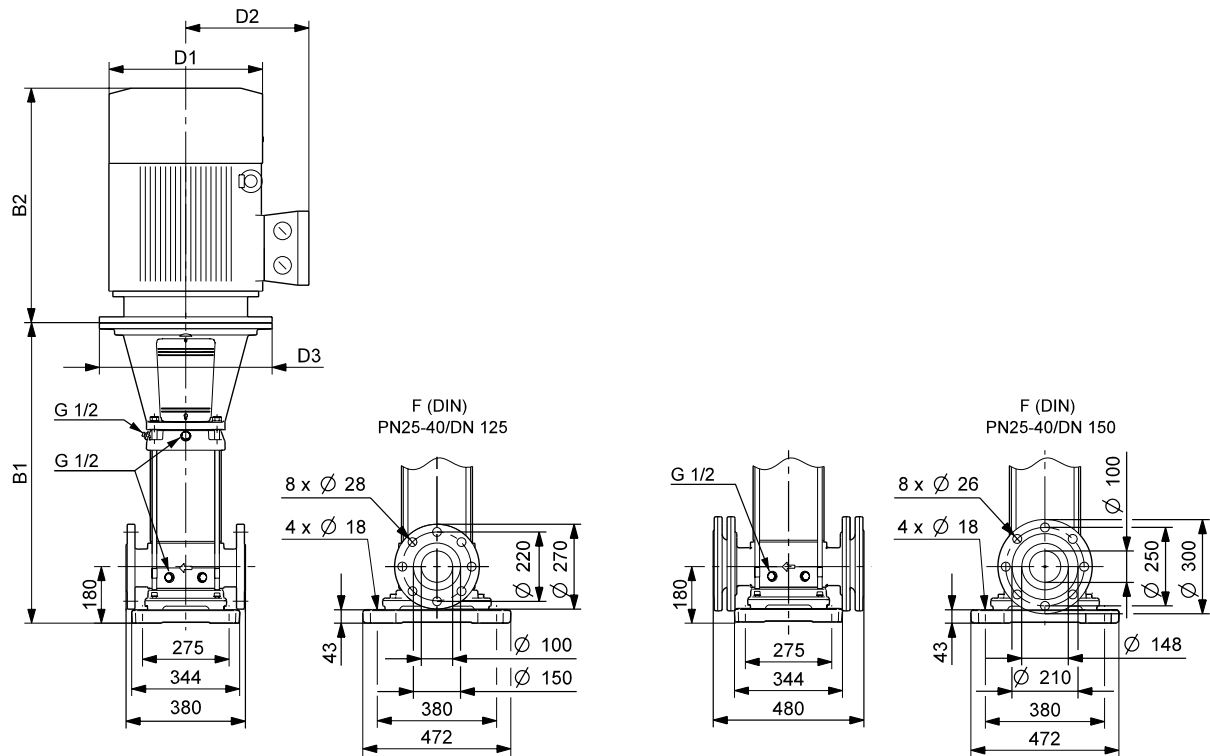

Dimensions and weights

Pump type	Motor P ₂ [kW]	Dimension [mm]					Net weight [kg]
		B1	B1+B2	D1	D2	D3	
CRN 120-1	11	834	1333	260	172	350	175
CRN 120-2-1	18.5	990	1508	320	197	350	210
CRN 120-2	22	990	1600	363	262	350	296
CRN 120-3	30	1145	1791	415	300	400	356
CRN 120-4-1	37	1301	2004	415	300	400	395
CRN 120-5-1	45	1456	2165	442	325	450	485
CRN 120-6-1	55	1642	2389	495	392	550	630
CRN 120-7	75	1798	2618	555	432	550	775

For information about maximum operating pressure, please see page 17.

CR 150

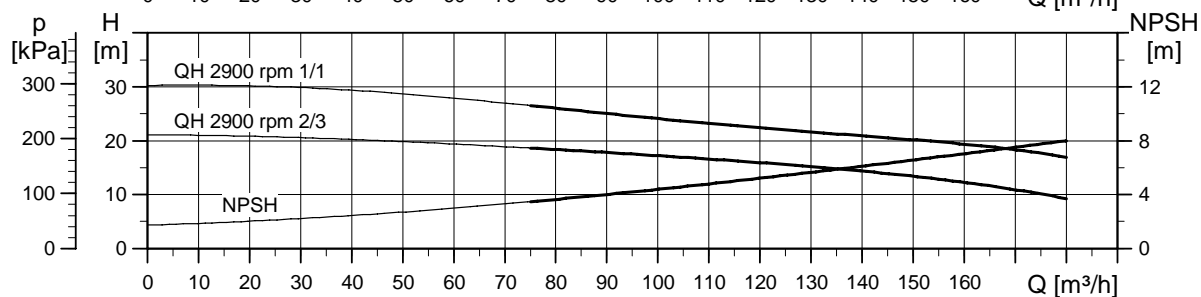
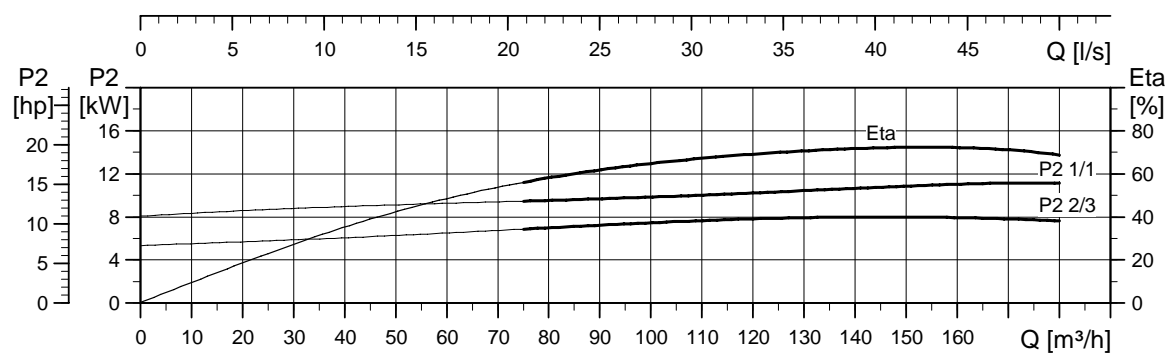
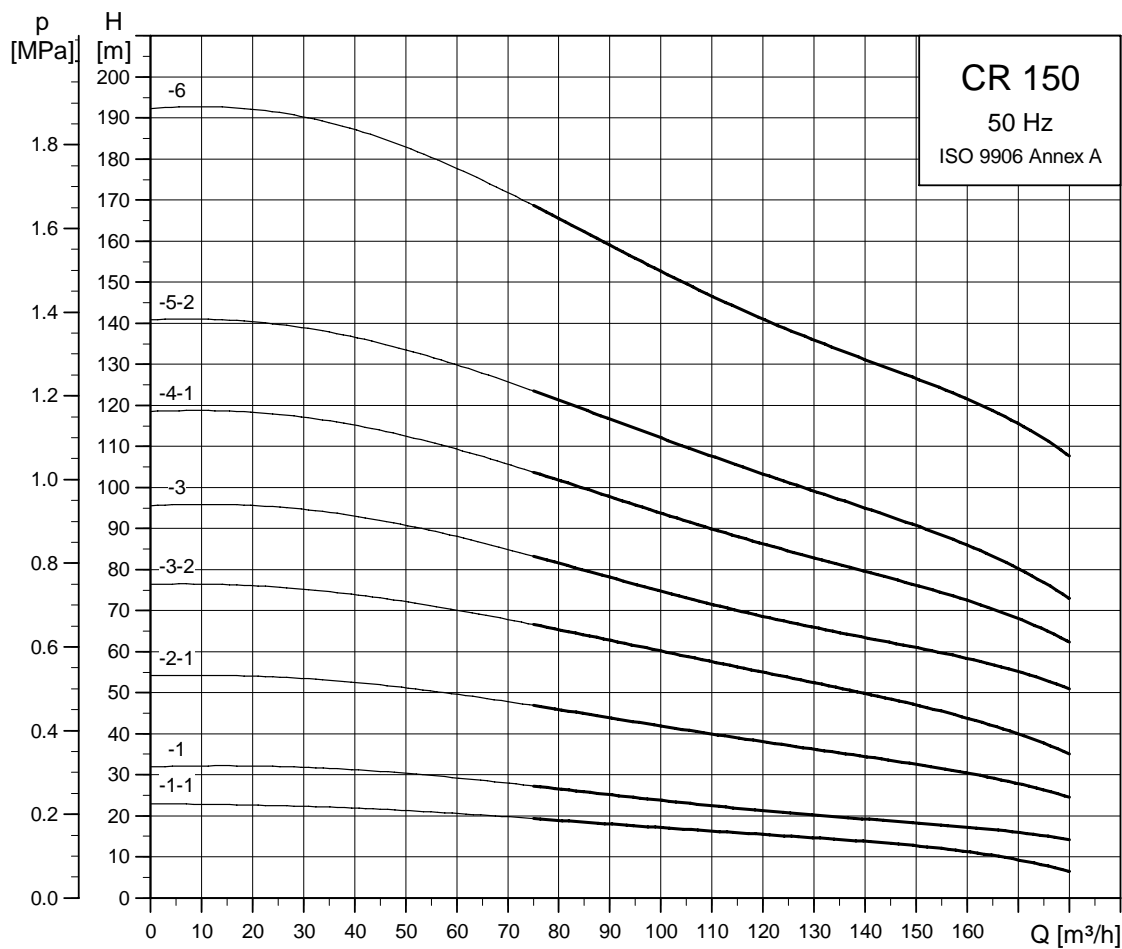

TM03 8745 2407

Dimensional sketch

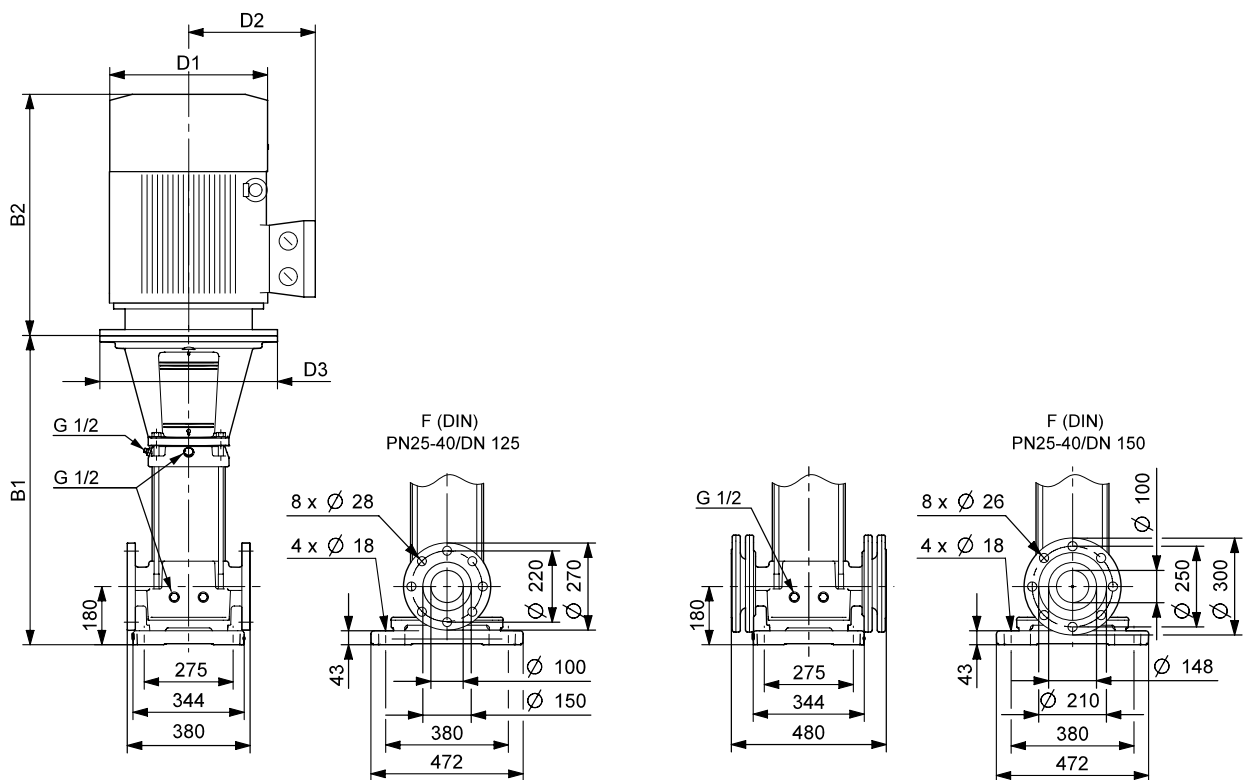

TM03 5999 4106

Dimensions and weights

Pump type	Motor P ₂ [kW]	Dimension [mm]					Net weight [kg]
		B1	B1+B2	D1	D2	D3	
CR 150-1-1	11	834	1333	260	172	350	172
CR 150-1	15	834	1312	320	197	350	190
CR 150-2-1	22	990	1600	363	262	350	293
CR 150-3-2	30	1145	1791	415	300	400	353
CR 150-3	37	1145	1848	415	300	400	383
CR 150-4-1	45	1301	2010	442	325	450	472
CR 150-5-2	55	1486	2233	495	392	550	617
CR 150-6	75	1642	2462	555	432	550	766

For information about maximum operating pressure, please see page 17.

CRN 150

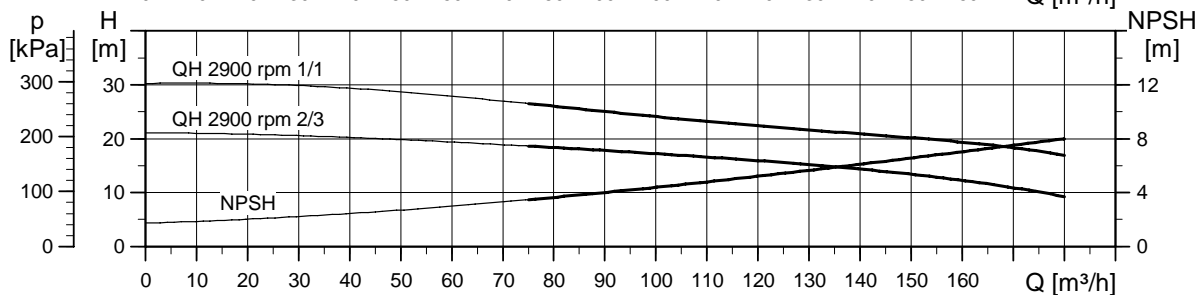
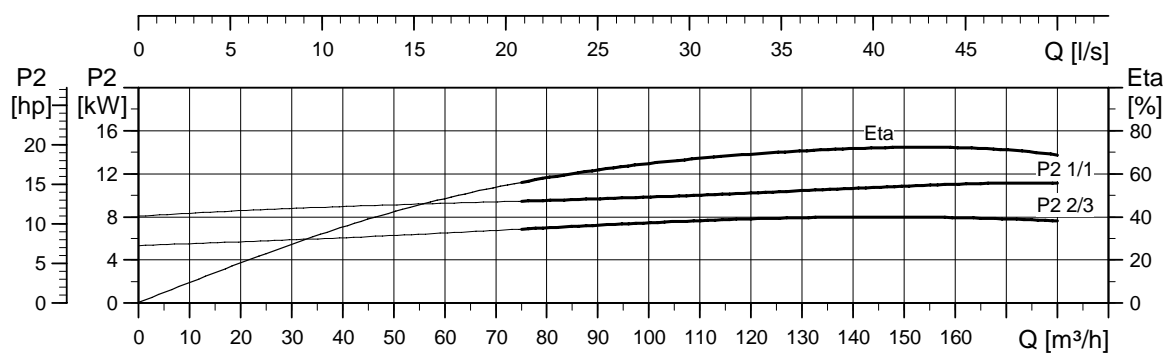
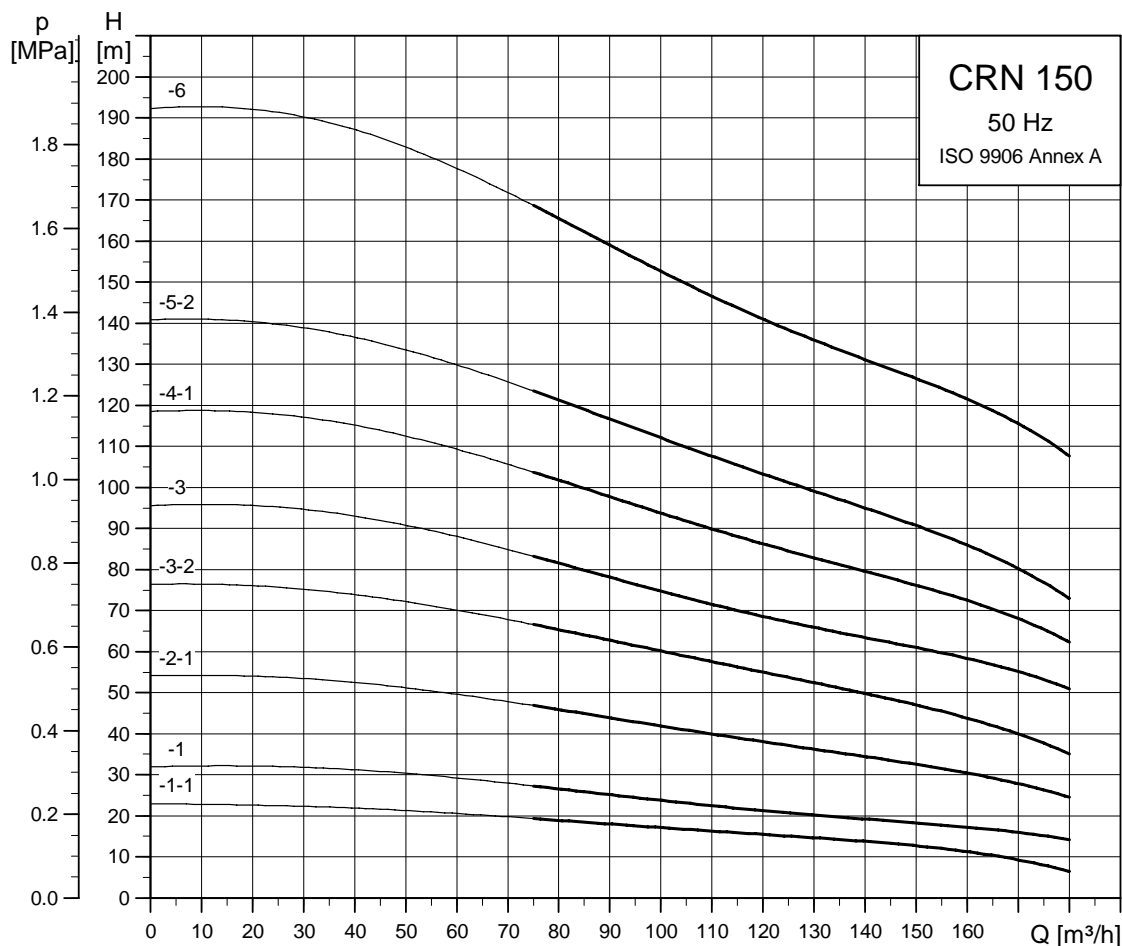

TM03 8746 2407

Dimensional sketch

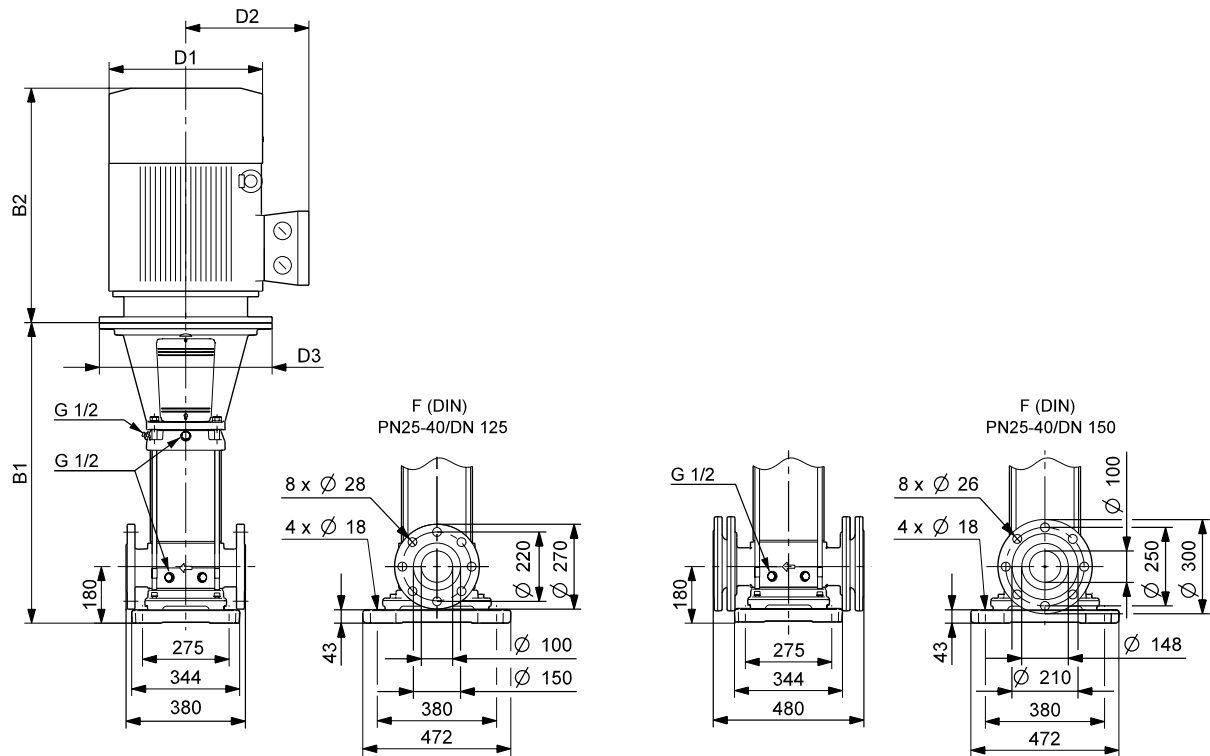

TM03 8889 2707

Dimensions and weights

Pump type	Motor P ₂ [kW]	Dimension [mm]					Net weight [kg]
		B1	B1+B2	D1	D2	D3	
CRN 150-1-1	11	834	1333	260	172	350	175
CRN 150-1	15	834	1312	320	197	350	193
CRN 150-2-1	22	990	1600	363	262	350	296
CRN 150-3-2	30	1145	1791	415	300	400	356
CRN 150-3	37	1145	1848	415	300	400	386
CRN 150-4-1	45	1301	2010	442	325	450	475
CRN 150-5-2	55	1486	2233	495	392	550	621
CRN 150-6	75	1642	2462	555	432	550	766

For information about maximum operating pressure, please see page 17.

Electrical data 240/1/50

Pump models: CRI/CRN 1, 3, 5, 10, 15, 20

Motor P ₂ [kW]	I _{1/1} [A]	Cos φ 1/1	η [%]	$\frac{I_{start}}{I_{1/1}}$	Sound pressure [dBA]	Product code
0.37	2.70	0.99	60	2.8	58	85215102
0.55	3.65	0.99	66	2.8	58	85215103
0.75	4.75	0.99	69	3.0	59	85215104
1.1	6.70	0.99	73	3.9	65	85215705
1.5	8.90	0.99	74	3.9	66	85215706
2.2	12.60	1.00	75	3.3	66	85215708

Dimensions

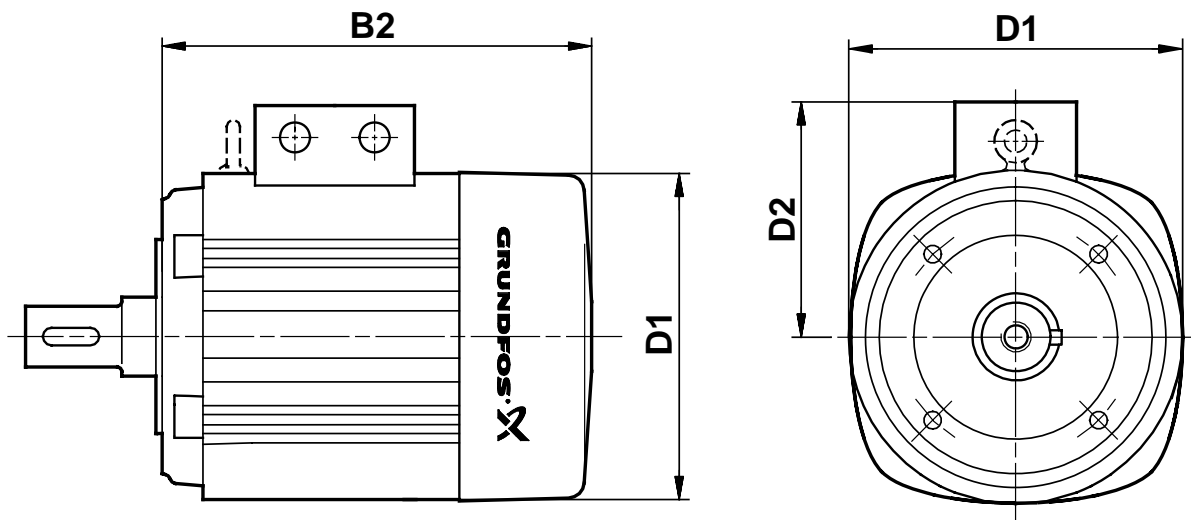

Pump models: CRI/CRN 1, 3, 5, 10, 15, 20

Motor [kW]	B2	D1	D2
0.37	191	141	133
0.55	231	141	133
0.75	231	141	133
1.1	281	178	139
1.5	321	178	139
2.2	321	178	139





TMO2 8485 0204

Standard motors for CR, CRI, CRN, 50 Hz

Motor P ₂ [kW]	Frame size	Standard voltage [V]	I _{1/1} [A]	Cos φ _{1/1}	η[%]	I _{start}	Speed [rpm]	Sound pressure [dBA]	
0.37	71	220-240Δ/380-415Y	1.7/1	0.80-0.70	78.5	8.5-9.2/4.9-5.3	2850-2880	53	 <p>MG</p> <p>TM03 1711 2805</p>
0.55	71	220-240Δ/380-415Y	2.5/1.4	0.80-0.70	80	12-13/6.9-7.5	2830-2850	53	
0.75	80	220-240Δ/380-415Y	3.3/1.9	0.81-0.71	81	19.1-20.5/11.0-11.8	2840-2870	53	
1.1	80	220-240Δ/380-415Y	4.5/2.6	0.84-0.76	82.8	28.5-31.5/16.3-17.9	2820-2860	53	
1.5	90	220-240Δ/380-415Y	5.5/3.2	0.87-0.82	85.5	46.3-50.7/26.8-29.3	2890-2910	58	
2.2	90	380-415Δ	4.5-4.5	0.89-0.87	87.5	37.8-42.3	2890-2910	60	
3.0	100	380-415Δ	6.3-6.3	0.87-0.82	87.5	52.9-58.0	2900-2920	59.5	
4.0	112	380-415Δ	8-8	0.88-0.84	89	89.6-98.4	2910-2930	63	
5.5	132	380-415Δ	11.2-11.2	0.88-0.84	90	119.8-131.0	2910-2930	62	
7.5	132	380-415Δ	15.2-15.2	0.87-0.80	89.5	152-168.7	2900-2920	68	
11	160	380-415Δ	21.4-21.4	0.90-0.90	91.4	156.2-171.2	2920-2930	70	
15	160	380-415Δ/660-690Y	26.5/15.2	0.90-0.90	91.5	185.5/106.4	2945	63	 <p>Siemens</p> <p>TM03 1710 2805</p>
18.5	160	380-415Δ/660-690Y	31.5/18.4	0.92-0.92	92.5	220.5/128.8	2940	63	
22	180	380-415Δ/660-690Y	38.5/22	0.88-0.88	94	277.2/158.4	2955	67	
30	200	380-415Δ/660-690Y	53/30.5	0.88-0.88	93.5	371/213.5	2960	71	
37	200	380-415Δ/660-690Y	64/37	0.89-0.89	94	460.8/266.4	2960	71	
45	225	380-415Δ/660-690Y	77/44.5	0.89-0.89	95	562.1/324.9	2965	71	
55	250	380-415Δ/660-690Y	93/54	0.90-0.90	95.5	632.4/367.2	2975	71	
75	280	380-415Δ/660-690Y	128/74	0.89-0.89	95	896-832/518-481	2975	73	

E-motors for CRE, CRIE, CRNE, 50 Hz

Motor P ₂ [kW]	Frame size	Phase	Standard voltage [V]	I _{1/1} [A]	Cos φ _{1/1}	η[%]	Sound pressure [dBA]		
0.37	71	1	200-240	2.7-2.5	0.96	68	59	 <p>MGE</p> <p>TM03 1712 2805</p>	
0.55	71	1	200-240	3.9-3.6	0.96	70	59		
0.75	80	1	200-240	5.1-4.7	0.97	72	58		
1.1	80	1	200-240	7.4-6.8	0.97	73	60		
0.75*	90	3	380-480	2.1-1.8	0.80-0.70	77	60		
1.1*	90	3	380-480	2.6-2.3	0.88-0.77	78	60		
1.5	90	3	380-480	3.3-2.7	0.91-0.87	81	65		
2.2	90	3	380-480	4.6-3.8	0.92-0.90	83	65		
3.0	100	3	380-480	6.2-5.0	0.94-0.92	83	65		
4.0	112	3	380-480	8.1-6.6	0.94-0.92	85	70		
5.5	132	3	380-480	11-8.8	0.94-0.93	85.5	75		
7.5	132	3	380-480	15-12	0.94-0.93	85	76		
11	160	3	380-415	21.4	0.93	84	69		 <p>MMGE</p> <p>TM03 1713 2805</p>
15	160	3	380-415	28	0.94	85.5	70		
18.5	160	3	380-415	34	0.95	85.5	70		
22	180	3	380-415	42	0.94	85	73		

* Pumps are normally fitted with single-phase MGE motors. Previous dimensions tables show pumps with single-phase MGE motors

Motor starting

Motors 4kW and above are generally suitable for star delta starting, however, it is recommended to start Grundfos pump products direct on line as there is no benefit in star delta starting with low inertia loads, even for kW ratings up to 90kW.

When direct on line starting low inertia loads, the run up time to full speed is approximately 0.1 seconds. After this period the motor is running at full speed and the current is down to the full load current or less, depending on the load. The full direct on line starting current (LRC) is only seen for less than 0.1 seconds. Direct on line starting currents of this duration do not cause significant heating of the supply cable when sized according to normal practice.

When starting star delta low inertia loads, the low moment of inertia of the pump is insufficient to maintain the motor at the star speed during the transition period from star into delta (typically 0.1 seconds). During the transition period the motor slows down to approximately 50% of the star speed. When the motor is then reconnected in delta, the full direct on line starting current then appears.

In summary, when star delta starting two transients are seen on the supply. The first is the normal star starting current ($0.33 \times \text{LRC}$), and the second being the full direct on line starting current ($6 \text{ to } 9 \times \text{FLC}$). Therefore, star delta starting of low inertia loads does not eliminate or reduce the direct on line starting current. Direct on line starting of low inertia loads simplifies panel design and reduces costs.

Please note: For high inertia loads, where the run up time is long, motors should be star delta started.

Pumped liquids

Thin, non-explosive liquids, not containing solid particles or fibres. The liquid must not chemically attack the pump materials.

When pumping liquids with a density and/or viscosity higher than that of water, use oversized motors, if required.

Whether a pump is suitable for a particular liquid depends on a number of factors of which the most important are the chloride content, pH value, temperature and content of chemicals, oils, etc.

Please note that aggressive liquids, such as sea water and some acids, may attack or dissolve the protective oxide film of the stainless steel and thus cause corrosion.

The CR(E), CRI(E), CRN(E) pump types are suitable for the following liquids:

CR(E), CRI(E)

CR(E), CRI(E) pumps are suitable for non-corrosive liquids.

Use CR(E), CRI(E) pumps for liquid transfer, circulation and pressure boosting of cold or hot clean water.

CRN(E)

CRN(E) pumps are suitable for industrial liquids.

Use CRN(E) pumps in systems where all parts in contact with the liquid must be made of high-grade stainless steel.

CRT(E)

CRT(E) pumps are suitable for these liquids:

- saline liquids
- hypochlorites
- acids.

For saline or chloride-containing liquids such as sea water or for oxidizing agents such as hypochlorites, Grundfos offers CRT(E) pumps made of titanium. See separate data booklet on CRT(E), accessible in WebCAPS page 75.

List of pumped liquids

A number of typical liquids are listed below.

Other pump versions may be applicable, but those stated in the list are considered to be the best choices.

The table is intended as a general guide only and cannot replace actual testing of the pumped liquids and pump materials under specific working conditions.

However, use the list with some caution. Factors such as those mentioned below may affect the chemical resistance of a specific pump version:

- concentration of the pumped liquid
- liquid temperature
- pressure.

Take safety precautions when pumping dangerous liquids.

Notes

D	Often with additives.
E	The density and/or viscosity differ from that/those of water. Take this factor into account when calculating motor output and pump performance.
F	Pump selection depends on many factors. Contact Grundfos.
H	Risk of crystallisation/precipitation in shaft seal.
1	Highly inflammable liquid.
2	Combustible liquid.
3	Insoluble in water.
4	Low self-ignition point.

Pumped liquid	Note	Liquid concentration, liquid temperature	CR(E), CRI(E)	CRN(E)
Acetic acid, CH ₃ COOH	-	5 %, +20 °C	-	HQQE
Acetone, CH ₃ COCH ₃	1, F	100 %, +20 °C	-	HQQE
Alkaline degreasing agent	D, F	-	HQQE	-
Ammonium bicarbonate, NH ₄ HCO ₃	E	20 %, +30 °C	-	HQQE
Ammonium hydroxide, NH ₄ OH	-	20 %, +40 °C	HQQE	-
Aviation fuel	1, 3, 4, F	100 %, +20 °C	HQBv	-
Benzoic acid, C ₆ H ₅ COOH	H	0.5 %, +20 °C	-	HQQv
Boiler water	-	< +120 °C	HQQE	-
	F	+120 °C - +180 °C	-	-
Calcareous water	-	< +90 °C	HQQE	-
Calcium acetate (as coolant with inhibitor) Ca(CH ₃ COO) ₂	D, E	30 %, +50 °C	HQQE	-
Calcium hydroxide, Ca(OH) ₂	E	Saturated solution, +50 °C	HQQE	-
Chloride-containing water	F	< +30 °C, max. 500 ppm	-	HQQE
Chromic acid, H ₂ CrO ₄	H	1 %, +20 °C	-	HQQv
Citric acid, HOC(CH ₂ CO ₂ H) ₂ COOH	H	5 %, +40 °C	-	HQQE
Completely desalinated water (demineralized water)	-	+120 °C	-	HQQE

Pumped liquids

CR, CRI, CRN,
CRE, CRIE, CRNE

Pumped liquid	Note	Liquid concentration, liquid temperature	CR(E), CRI(E)	CRN(E)
Condensate	-	120 °C	HQQE	-
Copper sulphate, CuSO ₄	E	10 %, +50 °C	-	HQQE
Corn oil	D, E, 3	100 %, +80 °C	HQQV	-
Diesel oil	2, 3, 4, F	100 %, +20 °C	HQBV	-
Domestic hot water (potable water)	-	< +120 °C	HQQE	-
Ethanol (ethyl alcohol), C ₂ H ₅ OH	1, F	100 %, +20 °C	HQQE	-
Ethylene glycol, HOCH ₂ CH ₂ OH	D, E	50 %, +50 °C	HQQE	-
Formic acid, HCOOH	-	5 %, +20 °C	-	HQQE
Glycerine (glycerol), OHCH ₂ CH(OH)CH ₂ OH	D, E	50 %, +50 °C	HQQE	-
Hydraulic oil (mineral)	E, 2, 3	100 %, +100 °C	HQQV	-
Hydraulic oil (synthetic)	E, 2, 3	100 %, +100 °C	HQQV	-
Isopropyl alcohol, CH ₃ CHOHCH ₃	1, F	100 %, +20 °C	HQQE	-
Lactic acid, CH ₃ CH(OH)COOH	E, H	10 %, +20 °C	-	HQQV
Linoleic acid, C ₁₇ H ₃₁ COOH	E, 3	100 %, +20 °C	HQQV	-
Methanol (methyl alcohol), CH ₃ OH	1, F	100 %, +20 °C	HQQE	-
Motor oil	E, 2, 3	100 %, +80 °C	HQQV	-
Naphthalene, C ₁₀ H ₈	E, H	100 %, +80 °C	HQQV	-
Nitric acid, HNO ₃	F	1 %, +20 °C	-	HQQE
Oil-containing water	-	< +100 °C	HQQV	-
Olive oil	D, E, 3	100 %, +80 °C	HQQV	-
Oxalic acid, (COOH) ₂	H	1 %, +20 °C	-	HQQE
Ozone-containing water, (O ₃)	-	< +100 °C	-	HQQE
Peanut oil	D, E, 3	100 %, +80 °C	HQQV	-
Petrol	1, 3, 4, F	100 %, +20 °C	HQBV	-
Phosphoric acid, H ₃ PO ₄	E	20 %, +20 °C	-	HQQE
Propanol, C ₃ H ₇ OH	1, F	100 %, +20 °C	HQQE	-
Propylene glycol, CH ₃ CH(OH)CH ₂ OH	D, E	50 %, +90 °C	HQQE	-
Potassium carbonate, K ₂ CO ₃	E	20 %, +50 °C	HQQE	-
Potassium formate (as coolant with inhibitor), KOOCH	D, E	30 %, +50 °C	HQQE	-
Potassium hydroxide, KOH	E	20 %, +50 °C	-	HQQE
Potassium permanganate, KMnO ₄	-	5 %, +20 °C	-	HQQE
Rape seed oil	D, E, 3	100 %, +80 °C	HQQV	-
Salicylic acid, C ₆ H ₄ (OH)COOH	H	0.1 %, +20 °C	-	HQQE
Silicone oil	E, 3	100 %	HQQV	-
Sodium bicarbonate, NaHCO ₃	E	10 %, +60 °C	-	HQQE
Sodium chloride (as coolant), NaCl	D, E	30 %, < +5 °C, pH > 8	HQQE	-
Sodium hydroxide, NaOH	E	20 %, +50 °C	-	HQQE
Sodium hypochlorite, NaOCl	F	0.1 %, +20 °C	-	HQQV
Sodium nitrate, NaNO ₃	E	10 %, +60 °C	-	HQQE
Sodium phosphate, Na ₃ PO ₄	E, H	10 %, +60 °C	-	HQQE
Sodium sulphate, Na ₂ SO ₄	E, H	10 %, +60 °C	-	HQQE
Softened water	-	< +120 °C	-	HQQE
Soya oil	D, E, 3	100 %, +80 °C	HQQV	-
Sulphuric acid, H ₂ SO ₄	F	1 %, +20 °C	-	HQQV
Sulphurous acid, H ₂ SO ₃	-	1 %, +20 °C	-	HQQE
Unsalted swimming pool water	-	Approx. 2 ppm free chlorine (Cl ₂)	HQQE	-

Counter flanges for CRI(E) and CRN(E)

Counter flanges for CRN(E) pumps are made of stainless steel to EN 1.4401 (AISI 316).

A counter flange set consists of one counter flange, one gasket, bolts and nuts.

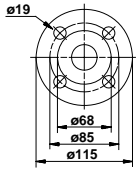
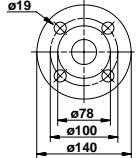
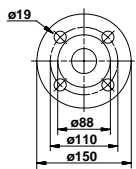
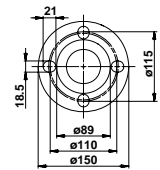
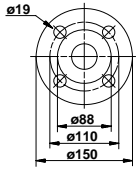
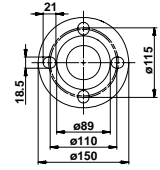
Counter flange	Pump type	Description	Rated pressure	Pipework connection	Product number	
	TM03 2115 3705	CRI(E), CRN(E) 1s, 1, 3, 5	Threaded	16 bar, EN 1092-2	Rp 1	91200656
			For welding	25 bar, EN 1092-2	25 mm, nominal	405285
	TM03 0400 3705	CRI(E), CRN(E) 1s, 1, 3, 5	Threaded	16 bar, EN 1092-2	Rp 1½	91200657
			For welding	25 bar, EN 1092-2	32 mm, nominal	415305
	TM03 0401 3705		Threaded	16 bar, EN 1092-2	Rp 1½	91201023
	TM02 7202 2803		Threaded	16 bar, EN 1092-2	Rp 2	96509570
		CRI(E) 10 CRN(E) 10				
	TM03 0401 3705		For welding	25 bar, EN 1092-2	40 mm, nominal	91201025
	TM02 7202 2803		For welding	25 bar, special flange	50 mm, nominal	96509571

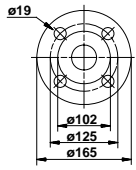
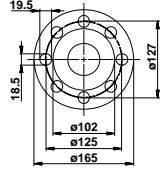
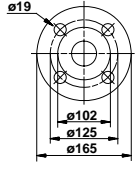
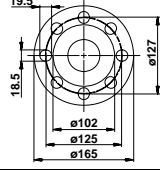
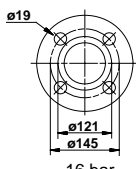
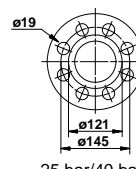
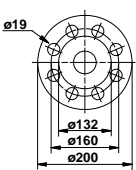
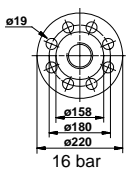
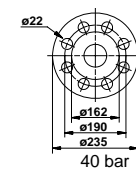
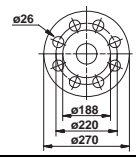
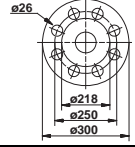
Counter flange	Pump type	Description	Rated pressure	Pipework connection	Product number
	TM00 0402 3705	Threaded	16 bar, EN 1092-2	Rp 2	91201026
	TM02 7203 2803	Threaded	16 bar, special flange	Rp 2½	96509575
		Threaded	16 bar, special flange	Rp 2½ ★	96509579
		CRI(E) 15, 20 CRN(E) 15, 20			
	TM03 0402 3705	For welding	40 bar, EN 1092-2	50 mm, nominal	91201028
	TM00 7203 2803	For welding	25 bar, special flange	65 mm, nominal	96509573
	TM03 2119 3705	Threaded	16 bar	Rp 2½	349910
		Threaded	16 bar, special flange	Rp 3	349911
16 bar		For welding	16 bar	65 mm, nominal	349906
25 bar/40 bar		For welding	40 bar	65 mm, nominal	349908
		For welding	16 bar, special flange	80 mm, nominal	349907
		For welding	25 bar, special flange	80 mm, nominal	349909
	TM03 2117 3705	Threaded	16 bar	Rp 3	350543
		For welding	16 bar	80 mm, nominal	350544
		For welding	40 bar	80 mm, nominal	350545
	TM03 2118 3705	Threaded	16 bar	Rp 4	369904
		For welding	16 bar	100 mm, nominal	369903
16 bar		For welding	40 bar	100 mm, nominal	369906
	TM03 8892 2707	For welding	40 bar, EN 1092-2	125 mm, nominal	96750477
		CRN 120 CRN 150			
	TM03 8891 2707	For welding	40 bar, EN 1092-2	150 mm, nominal	96750478

★ Flange with 20 mm higher collar. With this collar, the installation dimensions of a CR 20 will be identical to those of a CR 32.
If a CR 32 is replaced with a CR 20, the base must be raised by 15 mm.

PJE couplings for CRN(E)

Materials in contact with the pumped liquid are made of stainless steel to EN 1.4401 (AISI 316) and rubber.

A PJE coupling set consists of two coupling halves (Vic-taulic, type 77), one gasket, one pipe stud (for welding or threaded), bolts and nuts.

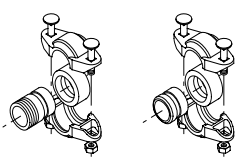
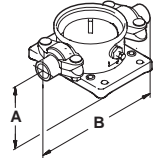
Coupling	Pump type	Pipe stub	PN	A	B	Pipework connection	Rubber parts	Number of coupling sets needed	Product number
	TM00 3808 1094	Threaded	80 bar	50	320	R 1¼	EPDM	2	419911
							FKM	2	419905
		For welding	80 bar	50	280	DN 32	EPDM	2	419912
							FKM	2	419904
	TM03 8890 2707	Threaded	70 bar	80	377	R 2	EPDM	2	339911
							FKM	2	339918
		For welding	70 bar	80	371	DN 50	EPDM	2	339910
							FKM	2	339917

FlexiClamp base connections

All sets comprise the necessary number of bolts and nuts as well as a gasket/O-ring.

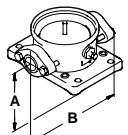
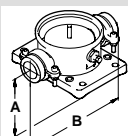
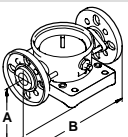
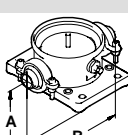
Base connection	Pump type	Connection	Pipework connection	PN	A	B	Rubber parts	Number of coupling sets needed	Product number
	TM02 7368 3303	Oval (stainless steel)	Rp 1	16	50	210	Klingsil	2	96449746
			Rp 1¼				Klingsil	2	96449747
	TM02 7369 3303	Union	G 2	25	50	228	EPDM	2	96449743
			FKM				2	96449744	
	TM02 7370 3303	DIN (stainless steel)	DN 25	16	75	250	EPDM	2	96449745
			DN 32				FKM	2	96449900
	TM02 7371 3303	Clamp, threaded pipe stub	Rp 1	25	50	208	EPDM	2	405280
			FKM				2	405281	
			Rp 1¼				EPDM	2	415296
			FKM				2	415297	
			1" NPT				EPDM	2	405291
			FKM				2	405292	
			1¼" NPT				EPDM	2	415311
			FKM				2	415312	
			28.5				EPDM	2	405282
			FKM				2	405283	
Clamp, pipe stub for welding	EPDM	2	415300						
	FKM	2	415301						

The shaded area designates optional pipe work connection options.

Accessories

CR, CRI, CRN,
CRE, CRIE, CRNE

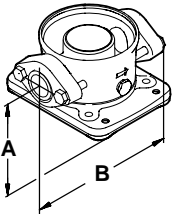
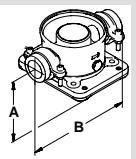
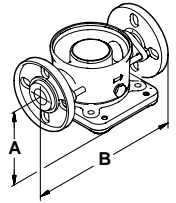
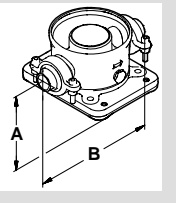
Base connection	Pump type	Connection	Pipework connection	PN	A	B	Rubber parts	Number of coupling sets needed	Product number	
	CRI(E) 10 CRN(E) 10	Oval (stainless steel)	Rp 1½	16	80	260	Klingersil	2	96498776	
			Rp 1½				Klingersil	2	96498728	
			Rp 2				Klingersil	2	96498835	
	CRI(E) 10 CRN(E) 10	Union	G 2¼	25	80	288	EPDM	2	96500275	
							FKM	2	96500276	
	CRI(E) 10 CRN(E) 10	FGJ (cast iron)	DN 40	16	80	316	EPDM	2	96498840	
							FKM	2	96500119	
							FGJ (stainless steel)	EPDM	2	96500263
								FKM	2	96500264
							FGJ (cast iron)	EPDM	2	96500265
								FKM	2	96500266
	CRI(E) 10 CRN(E) 10	Clamp, threaded pipe stub	Rp 2	25	80	346	EPDM	2	425238	
							FKM	2	425239	
							Rp 1½	EPDM	2	335241
								FKM	2	335242
							Rp 2½	EPDM	2	96508600
								FKM	2	96508601
Clamp, pipe stub for welding	EPDM	2	425242							
	FKM	2	425243							
	EPDM	2	335251							
	FKM	2	335252							

The shaded area designates optional pipe work connection options.

Pipework connection

Various sets of counter flanges and couplings are available for pipework connection.

Counter flanges for CR(E)

A counter flange set consists of one counter flange, one gasket, bolts and nuts.

Counter flange	Pump type	Description	Rated pressure	Pipework connection	Product number	
	TM03 2116 3705	CR(E) 32	Threaded	16 bar, EN 1092-2	Rp 2½	349902
			Threaded	16 bar, special flange	Rp 3	349901
			For welding	16 bar, EN 1092-2	65 mm, nominal	349904
			For welding	40 bar, DIN 2635	65 mm, nominal	349905
			For welding	16 bar, special flange	80 mm, nominal	349903
	TM03 2117 3705	CR(E) 45	Threaded	16 bar	Rp 3	350540
			For welding	16 bar	80 mm, nominal	350541
			For welding	40 bar	80 mm, nominal	350542
	TM03 2118 3705	CR(E) 64 CR(E) 90	Threaded	16 bar, EN 1092-2	Rp 4	369901
			For welding	16 bar, EN 1092-2	100 mm, nominal	369902
			For welding	25 bar, EN 1092-2	100 mm, nominal	369905
	TM03 8892 2707	CR 120 CR 150	For welding	40 bar, EN 1092-2	125 mm, nominal	96750475
	TM03 8891 2707		For welding	40 bar, EN 1092-2	150 mm, nominal	96750476

★ Flange with 20 mm higher collar. With this collar, the installation dimensions of a CR 20 will be identical to those of a CR 32.
If a CR 32 is replaced with a CR 20, the base must be raised by 15 mm.

Potentiometer for CRE, CRIE, CRNE

The potentiometer is for setpoint setting and start/stop of the CRE, CRIE, CRNE pump.

Product	Product number
External potentiometer with cabinet for wall mounting	625468

G10-LON interface for CRE, CRIE, CRNE

Use the G10-LON interface in connection with data transmission between a Locally Operating Network (LON) and electronically controlled Grundfos pumps applying the Grundfos bus-protocol GENIbus.

Product	Product number
G10-LON interface	00605726

LiqTec for CR(E), CRI(E) and CRN(E)

The LiqTec dry-running protection device protects pump and process against dry-running and temperatures exceeding 130 °C ±5 °C. Connected to the motor PTC sensor, LiqTec also monitors the motor temperature.

LiqTec is prepared for DIN rail mounting in control cabinet.

Enclosure class: IP X0.

Remote control, R100

Use the R100 for wireless communication with the CRE, CRIE, CRNE pump. The communication takes place by means of infrared light.

Product	Product number
R100	625333

EMC filter for CRE, CRIE, CRNE

The EMC filter is required for installation of 11 to 22 kW E-pumps in residential areas.

Product	Product number
EMC-filter (11 kW)	96478309
EMC-filter (15 kW)	
EMC-filter (18.5 kW)	
EMC-filter (22 kW)	

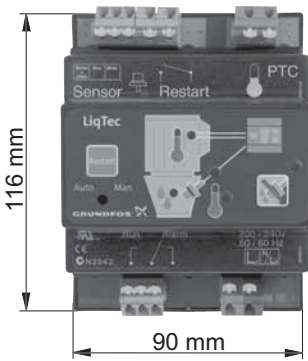
Dry-running protection	Pump type	Voltage [V]	LiqTec	Sensor, ½"	Cable, 5 m	Extension cable, 15 m	Product number
	CR(E) CRI(E) CRN(E)	200-240	●	●	●	-	96556429
		80-130	●	●	●	-	96556430
		-	-	-	-	●	96443676

TM03 2108 3705

Sensors for CRE, CRIE, CRNE

Accessory	Type	Supplier	Measuring range	Product number
Flowmeter	SITRANS FM MAGFLO MAG 5100 W	Siemens	1-5 m ³ (DN 25)	ID8285
Flowmeter	SITRANS FM MAGFLO MAG 5100 W	Siemens	3-10 m ³ (DN 40)	ID8286
Flowmeter	SITRANS FM MAGFLO MAG 5100 W	Siemens	6-30 m ³ (DN 65)	ID8287
Flowmeter	SITRANS FM MAGFLO MAG 5100 W	Siemens	20-75 m ³ (DN 100)	ID8288
Temperature sensor	TTA (0) 25	Carlo Gavazzi	0 °C to +25 °C	96432591
Temperature sensor	TTA (-25) 25	Carlo Gavazzi	-25 °C to +25 °C	96430194
Temperature sensor	TTA (50) 100	Carlo Gavazzi	+50 °C to +100 °C	96432592
Temperature sensor	TTA (0) 150	Carlo Gavazzi	0 °C to +150 °C	96430195
Accessory for temperature sensor. All with ½ RG connection	Protecting tube Ø9 x 50 mm	Carlo Gavazzi		96430201
	Protecting tube Ø9 x 100 mm	Carlo Gavazzi		96430202
	Cutting ring bush	Carlo Gavazzi		96430203
Temperature sensor, ambient temperature	WR 52	tmg (DK: Plesner)	-50 °C to +50 °C	ID8295
Differential temperature sensor	ETSD	Honsberg	0 °C to +20 °C	96409362
Differential temperature sensor	ETSD	Honsberg	0 °C to +50 °C	96409363

Note: All sensors have 4-20 mA signal output.

Danfoss pressure sensor kits for CRE, CRIE, CRNE 1, 3, 5, 10, 15, 20, 32, 45, 64 and 90

The kit comprises:	Pressure range	Temperature range	Product number
<ul style="list-style-type: none"> Danfoss pressure transmitter, type MBS 3000, with 2 m screened cable Connection: G ½ A (DIN 16288 - B6kt) 5 cable clips (black) Instruction manual PT (00 40 02 12) 	0-4 bar	-40 °C to +85 °C	96428014
	0-6 bar		96428015
	0-10 bar		96428016
	0-16 bar		96428017
	0-25 bar		96428018

DPI differential pressure sensor kit

The kit comprises:	Pressure range	Product number
<ul style="list-style-type: none"> 1 sensor incl. 0.9 m screened cable (7/16" connections) 1 original DPI bracket (for wall mounting) 1 Grundfos bracket (for mounting on motor) 2 M4 screws for mounting of sensor on bracket 1 M6 screw (self-cutting) for mounting on MGE 90/100 1 M8 screw (self-cutting) for mounting on MGE 112/132 3 capillary tubes (short/long) 2 fittings (1/4" - 7/16") 5 cable clips (black) Installation and operating instructions (00480675) Service kit instructions. 	0-0.6 bar	96611522
	0-1.0 bar	96611523
	0-1.6 bar	96611524
	0-2.5 bar	96611525
	0-4.0 bar	96611526
	0-6.0 bar	96611527
	0-10 bar	96611550

Lists of variants - on request

Although the Grundfos CR(E), CRI(E), CRN(E) product range offers a number of pumps for different applications, customers require specific pump solutions to satisfy their needs. See following documents:

- Grundfos CR "Custom-built pumps" catalogue
- Grundfos "CR, CRN high pressure" data booklet.

Below please find the range of options available for customizing the CR(E) pumps to meet the customers' demands.

Contact Grundfos for further information or for requests other than the ones mentioned below.

Motors

Variant	Description
ATEX motor	For operation in hazardous atmospheres, explosion-proof or dust-ignition-proof motors may be required.
Motor with anti-condensation heating unit	For operation in humid environments motors with built-in anti-condensation heating unit may be required.
Motor with thermal protection	Grundfos offers motors with built-in bimetallic thermal switches or temperature-controlled PTC sensors (thermistors) incorporated in the motor windings.
Oversize motor	Ambient temperatures above 40°C or installation at altitudes of more than 1000 metres above sea level require the use of an oversize motor (i.e. derating).
4-pole motor	Grundfos offers 4-pole standard motors.

Shaft seals

Variant	Description
Shaft seal with FFKM O-ring material	Shaft seals with FFKM or FXM O-ring material are recommended for applications where the pumped liquid may damage the standard O-ring material.
Seal with flush, quench seal	Recommended for applications involving crystallizing, hardening or sticky liquids.
Air-cooled shaft seal system	Recommended for applications involving extremely high temperatures. No conventional mechanical shaft seal can withstand liquid temperatures of up to 180°C for any length of time. For such applications, Grundfos' unique air-cooled shaft seal system is recommended. In order to ensure a low liquid temperature around the standard shaft seal, the pump is fitted with a special air-cooled shaft seal chamber. No separate cooling is required.
Double seal with pressure chamber	Recommended for applications involving poisonous or explosive liquids. Protects the surrounding environment and the people working in the vicinity of the pump. Consists of two seals mounted in a "back-to-back" arrangement inside a separate pressure seal chamber. As the pressure in the chamber is higher than the pump pressure, leakage is prevented. A dosing pump or a special pressure-intensifier generates the seal chamber pressure.
CR MAGdrive	Magnetically driven pumps for industrial applications. Key applications are industrial processes involving the handling of aggressive, environmental, dangerous or volatile liquids, e.g. organic compounds, solvents, etc.

Pumps

Variant	Description
Horizontally mounted pump	For safety or height reasons, certain applications, for instance on ships, require the pump to be mounted in the horizontal position. For easy installation the pump is equipped with brackets that support motor and pump.
Low-temperature pump	Exposed to temperatures down to -40 °C, coolant pumps may require neck-rings with a different diameter in order to prevent impeller drag.
High-speed pump up to 47 bar	For high-pressure applications, Grundfos offers a unique pump capable of generating up to 47 bar. The pump is equipped with a high-speed motor, type MGE. The direction of rotation is the opposite of that of standard pumps, and the chamber stack is turned upside-down, as a result of which the pumped liquid flows in the opposite direction.
High-pressure pump up to 47 bar	For high-pressure applications, Grundfos offers a unique double pump system capable of generating a pressure of up to 47 bar pressure.
Low-NPSH pump (improved suction)	Recommended for boiler-feed applications where cavitation may occur due to poor inlet conditions.
Pump with bearing flange	The bearing flange is suitable for applications where the inlet pressure is higher than the maximum pressure recommended. The bearing flange increases the life of motor bearings. (Recommended for standard motors.)
Belt-driven pump	Belt-driven pumps designed to operate in places with limited space or where no electrical power is available.
Pump for pharmaceutical and biotechnological applications	CRN(E) pumps designed for applications requiring the sterilization and CIP capability of pipes, valves and pumps. (CIP = Cleaning-In-Place.)

Connections and other variants

Variant	Description
Pipe connections	In addition to the wide range of standard flange connections, a 16 bar DIN standard clamping flange is available. Customized flanges are available according to specifications.
TriClamp connection	TriClamp connections are of a hygienic design with a sanitary coupling for use in the pharmaceutical and food industry.
Electropolished pump	To substantially reduce the risk of corrosion of the materials. For use in the pharmaceutical/food industry.

WebCAPS

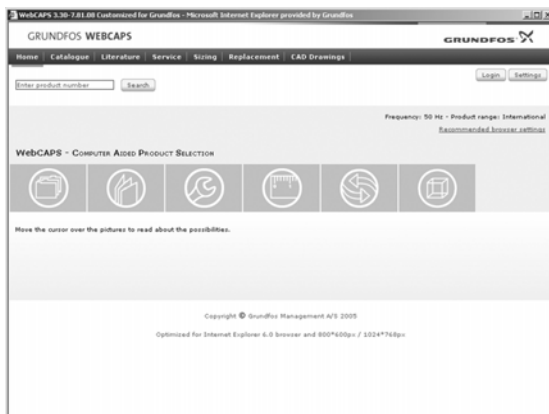

WebCAPS is a **Web-based Computer Aided Product Selection** program available on www.grundfos.com.

WebCAPS contains detailed information on more than 185,000 Grundfos products in more than 20 languages.

In WebCAPS, all information is divided into 6 sections:

- Catalogue
- Literature
- Service
- Sizing
- Replacement
- CAD drawings.

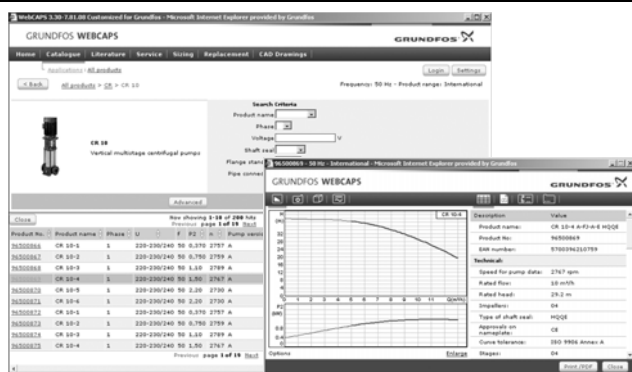

Catalogue

This section is based on fields of application and pump types, and contains

- technical data
- curves (QH, Eta, P1, P2, etc) which can be adapted to the density and viscosity of the pumped liquid and show the number of pumps in operation
- product photos
- dimensional drawings
- wiring diagrams
- quotation texts, etc.

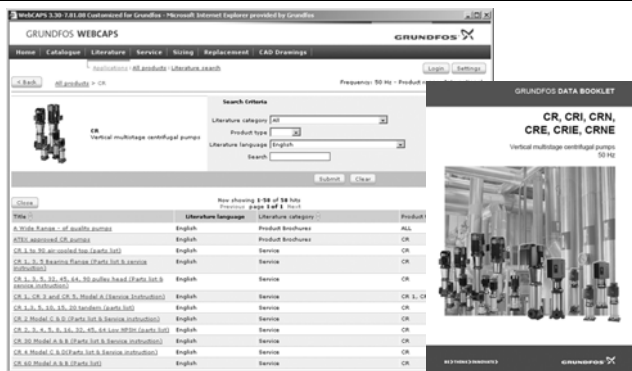

Literature

In this section you can access all the latest documents of a given pump, such as

- data booklets
- installation and operating instructions
- service documentation, such as Service kit catalogue and Service kit instructions
- quick guides
- product brochures.



Service

This section contains an easy-to-use interactive service catalogue. Here you can find and identify service parts of both existing and discontinued Grundfos pumps.

Furthermore, this section contains service videos showing you how to replace service parts.



Sizing

This section is based on different fields of application and installation examples, and gives easy step-by-step instructions in how to

- select the most suitable and efficient pump for your installation
- carry out advanced calculations based on energy consumption, payback periods, load profiles, life cycle costs, etc.
- analyse your selected pump via the built-in life cycle cost tool
- determine the flow velocity in wastewater applications, etc.



Replacement

In this section you find a guide to selecting and comparing replacement data of an installed pump in order to replace the pump with a more efficient Grundfos pump. The section contains replacement data of a wide range of pumps produced by other manufacturers than Grundfos.

Based on an easy step-by-step guide, you can compare Grundfos pumps with the one you have installed on your site. When you have specified the installed pump, the guide will suggest a number of Grundfos pumps which can improve both comfort and efficiency.

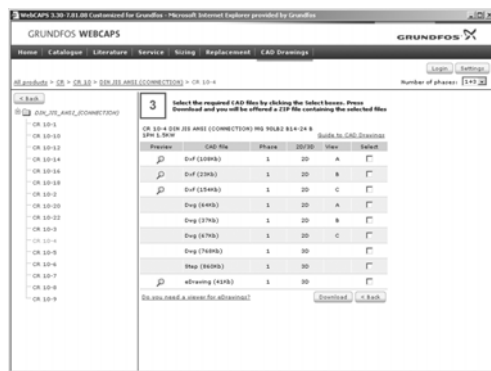

CAD drawings

In this section it is possible to download 2-dimensional (2D) and 3-dimensional (3D) CAD drawings of most Grundfos pumps.

These formats are available in WebCAPS:

- 2-dimensional drawings:
- .dxf, wireframe drawings
 - .dwg, wireframe drawings.
- 3-dimensional drawings:
- .dwg, wireframe drawings (without surfaces)
 - .stp, solid drawings (with surfaces)
 - .eprt, E-drawings.

WinCAPS



Fig. 28 WinCAPS CD-ROM

WinCAPS is a **Windows-based Computer Aided Product Selection** program containing detailed information on more than 185,000 Grundfos products in more than 20 languages.

The program contains the same features and functions as WebCAPS, but is an ideal solution if no Internet connection is available.

WinCAPS is available on CD-ROM and updated once a year.

To request a free copy of the WinCAPS CD-ROM, please visit the Grundfos UK web site at www.grundfos.co.uk.

GRUNDFOS PUMPS LTD

Office Addresses

Leighton Buzzard (Head Office): Grovebury Road, Leighton Buzzard, Beds. LU7 4TL
 Leigh Office: Orford Court, Greenfold Way, Leigh, Lancs. WN7 3XJ
 Livingston Office: Flemming Road, Kirton Campus, Livingston, West Lothian, Scotland EH54 7BN

Commercial Building Services

Livingston Office: Tel: 01506 461666, Fax: 01506 461555, Email: uklivquotes@grundfos.com
 Leigh Office: Tel: 08707 503888, Fax: 01942 605970, Email: ukcbsleigh@grundfos.com

Domestic Building Services

Leighton Buzzard Office: Tel: 01525 775402, Fax: 01525 775236, Email: uk-sales@grundfos.com

Water Distribution Group

Leighton Buzzard Office: Tel: 01525 775450, Fax: 01525 775224, Email: ukwater@grundfos.com

Water M&E Projects Team

Leighton Buzzard Office: Tel: 01525 775449, Fax: 01525 853981, Email: ukwatergroup@grundfos.com

Industrial End User Team

Leighton Buzzard Office: Tel: 01525 775292, Fax: 01525 775364, Email: ukindustry@grundfos.com

Original Equipment Manufacturer

Leighton Buzzard Office: Tel: 01525 775444, Fax: 01525 853981, Email: uk-sales@grundfos.com

Spares Team

Leigh Office: Tel: 01942 263490, Fax: 01942 603462 Email: ukspares@grundfos.com

Service

Mobile Service: Tel: 08450 508100, Fax: 01942 602830
 Service Workshop (Leigh): Tel: 01942 263627, Fax: 01942 603462

Grundfos Control Solutions

Telephone: 01525 850000 Fax: 01753 832335 email:uk-gcs@grundfos.com

General Sales Enquiries: uk-sales@grundfos.com

www.grundfos.co.uk

V7144411 0208	GB
Repl. V7144411 0106	

Subject to alterations.