

# Submersible Motors & Accessories Catalog



# **Commitment To Quality**

**Franklin Electric is committed to provide customers with defect free products through our program of continuous improvement. Quality shall, in every case, take precedence over quantity.**



# Submersible Motors & Accessories Catalog





# Submersible Motors Catalog Contents

## 4" Motors & Leads

Page



Super Stainless.....	3
High Thrust.....	10
Leads .....	17

## 6" Motors & Leads



Standard.....	18
Hi-Temp 90.....	30
Leads .....	37

## 8" Motors & Leads



Standard.....	39
Hi-Temp 75.....	46
Leads .....	52

## Control Boxes & Protection



Control Boxes.....	54
Control Box Parts.....	59
Single-Phase Motor Protection .....	62
Three-Phase Control Panels.....	64
Three-Phase Control Panel Accessories .....	66
SubMonitor™ Three-Phase Protection.....	68
D3 Data Download Tool.....	69

# Submersible Motors Catalog Contents

## Constant Pressure Controllers

Page



MonoDrive, MonoDriveXT, SubDrive75, SubDrive100, SubDrive150 & SubDrive300 .....	70
SubDrive Accessories.....	73

## Accessories & Services



Surge Arrestors.....	74
PT100 Sensors .....	74
Couplings .....	75
QD Service Box .....	77
Special Services.....	77



# 4" Submersible Motors Super Stainless



## Applications

These motors are built for dependable operation in 4" diameter or larger water wells.

## Basic Features

- Corrosion-resistant stainless steel exterior
- Stainless steel splined shaft
- Hermetically-sealed windings
- StatorShield™ resin system
- Filter check valve
- Water lubrication
- Kingsbury-type thrust bearing
- Pressure-equalizing diaphragm
- Built-in lightning arrestors (All single-phase; 200 & 300 V three-phase)
- Removable water bloc lead
- Franklin-manufactured control boxes available for single-phase motors
- UL 778 recognized (North American voltages)
- CSA certified
- ANSI/NSF 61 certified
- Industry standard NEMA mounting dimensions

## Special Features

- Flow inducer sleeve not required in water up to 86 °F (30 °C) for motors through 2 hp.
- Two-wire motors are split-phase designs with integral starting components and do not require a control box. They feature Franklin's patented 2-wire BIAC starting switch which provides Reverse Impact Torque to aid starting in adverse environments and prevents extreme fast cycling (e.g. water logged tank).
- Three-wire motors through 1 hp use Franklin's exclusive three-wire QD (Quick Disconnect) Control Box with the patented QD Relay. This relay provides the ultimate in operational life.
- Single-phase motors can be used with Pumptec products to protect against dry-run and other installation conditions that can damage motors and/or pumps. See Single-phase Protection Devices for details.

## Constant Pressure Options

- Use Franklin's MonoDrive controller with 1½ hp three-wire single-phase motors to provide constant water pressure.
- Three-phase motors can be used with SubDrive controllers to provide constant water pressure.

## Pollution Recovery Option

- Pollution Recovery motors are equipped for use in monitoring and recovery wells in which hydrocarbons and other chemicals may be present.
- Special Viton® rubber parts and other chemical resistant materials as listed in Construction Materials chart.

# 4" Submersible Motors Super Stainless

## 4-Inch Super Stainless Motor Specifications

Hz	Ph	Hp Range	kW Range	Poles	RPM	Max. Ambient Temp.	Duty Rating
60	2-Wire	0.3 - 1.5	0.25 - 1.1	2	3450	86 °F / 30 °C	Continuous
50	2-Wire	0.5 - 1.5	0.37 - 1.1	2	2875	86 °F / 30 °C	Continuous
60	3-Wire	0.3 - 3	0.25 - 2.2	2	3450	86 °F / 30 °C	Continuous*
50	3-Wire	0.3 - 3	0.25 - 2.2	2	2875	86 °F / 30 °C	Continuous*
60	Three-Phase	0.5 - 3	0.37 - 2.2	2	3450	86 °F / 30 °C	Continuous*
50	Three-Phase	0.5 - 3	0.37 - 2.2	2	2875	86 °F / 30 °C	Continuous*

## 4-Inch Pollution Recovery Motor Specifications

Hz	Ph	Hp Range	kW Range	Poles	RPM	Max. Ambient Temp.	Duty Rating
60	2-Wire	0.3 - 1.5	0.25 - 1.1	2	3450	86 °F / 30 °C	Continuous
50	2-Wire	0.5 - 1.5	0.37 - 1.1	2	2875	86 °F / 30 °C	Continuous
60	3-Wire	0.3 - 2	0.25 - 1.5	2	3450	86 °F / 30 °C	Continuous*
50	3-Wire	0.3 - 2	0.25 - 1.5	2	2875	86 °F / 30 °C	Continuous*
60	Three-Phase	0.5 - 2	0.37 - 1.5	2	3450	86 °F / 30 °C	Continuous*
50	Three-Phase	0.5 - 2	0.37 - 1.5	2	2875	86 °F / 30 °C	Continuous*

\* 3 hp motors require 0.25 ft/sec flow past motor.

## 4-Inch Construction Materials

Component	Construction Type	
	Standard Water Well	Pollution Recovery
Castings	304 SS over Iron	304 SS over Iron
Stator Shell	301 SS	301 SS
Shaft Extension	17-4 SS or 303 SS	303 SS
Fasteners	305 SS or 302 SS	316 SS
Seal Cover	Acetal	Tefzel®
Seal	Nitrile Rubber Lip	Viton®
Diaphragm	Nitrile Rubber	Viton®
Slinger	Nitrile Rubber	Viton®
Lead Wire (or Cable)	XLPE	Lead not furnished with motor
Lead Potting	Epoxy	Lead not furnished with motor
Lead Jam Nut	303 SS	Lead not furnished with motor

Specifications subject to change without notice. Contact Franklin Electric if current material types are required for bid specifications.

Viton® is a registered trademark of DuPont Dow Elastomers.

Tefzel® is a registered trademark of E.I. du Pont Nemours and Company.

# 4" Submersible Motors Super Stainless

## 4-Inch Dimensions and Weights

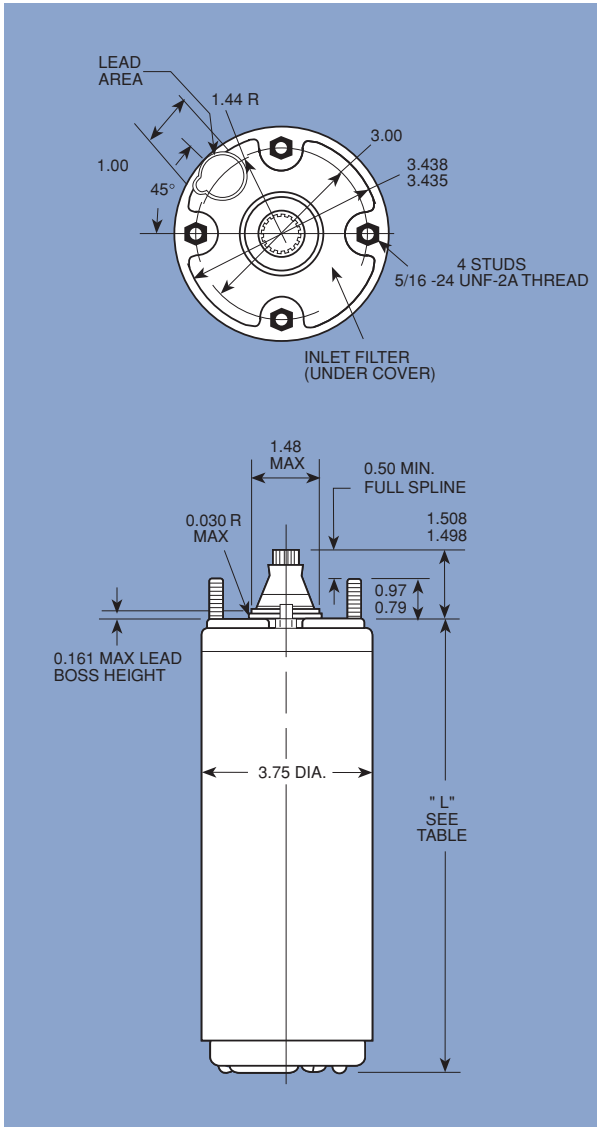

### Single-Phase Motors - 2-wire

HP	KW	"L" (inches)	SHIPPING WEIGHT		MOTOR CARTON SIZE (in inches)
			LBS	KG	
1/3	0.25	8.78	16	7.3	4 x 4.375 x 16
0.5	0.37	9.53	18	8.2	4 x 4.375 x 16
0.75	0.55	10.66	21	9.5	4 x 4.375 x 19
1	0.75	11.75	24	10.9	4 x 4.375 x 19
1.5	1.1	15.12	31	14.1	4 x 4.375 x 21

### Single-Phase Motors - 3-wire

HP	KW	"L" (inches)	SHIPPING WEIGHT		MOTOR CARTON SIZE (in inches)
			LBS	KG	
1/3	0.25	8.78	17	7.7	4 x 4.375 x 16
0.5	0.37	9.53	19	8.6	4 x 4.375 x 16
0.75	0.55	10.66	21	9.5	4 x 4.375 x 19
1	0.75	11.75	24	10.9	4 x 4.375 x 19
1.5	1.1	13.62	28	12.7	4 x 4.375 x 21
2	1.5	15.12	33	15.0	5 x 4.375 x 21
3	2.2	19.06	41	18.6	6 x 4.375 x 21

### Three-Phase Motors

HP	KW	"L" (inches)	SHIPPING WEIGHT		MOTOR CARTON SIZE (in inches)
			LBS	KG	
0.5	0.37	9.53	18	8.2	4 x 4.375 x 16
0.75	0.55	10.66	21	9.5	4 x 4.375 x 16
1	0.75	11.75	24	10.9	4 x 4.375 x 19
1.5	1.1	11.75	24	10.9	4 x 4.375 x 19
2	1.5	13.62	28	12.7	4 x 4.375 x 21
3	2.2	16.06	35	15.9	4 x 4.375 x 21

All dimensions listed above are for models supplied with lead. Consult factory for other models.

# 4" Submersible Motors Super Stainless

## 4-Inch 2-wire Models

HP (kW)	DESCRIPTION						MODEL	STOCK STATUS	DOWNWARD THRUST RATING	
	W/PH	CONSTRUCTION	VOLTS	HZ	S.F.	LEAD IN MTR				
<b>1/3 hp</b> <b>0.25 kW</b>	2-WIRE	WATER WELL	115	60	1.75		244 502 01--S		300 LBS (1500 N)	
			115	60	1.75	YES	244 502 90--S	YES		
			230	60	1.75		244 503 01--S			
		POLLUTION RECOVERY	230	60	1.75	YES	244 503 90--S	YES		
			115	60	1.75		244 502 09--S			
			230	60	1.75		244 503 09--S			
<b>1/2 hp</b> <b>0.37 kW</b>	2-WIRE	WATER WELL	115	60	1.60		244 504 01--S		300 LBS (1500 N)	
			115	60	1.60	YES	244 504 90--S	YES		
			220	50	1.00		244 555 01--S			
		POLLUTION RECOVERY	230	60	1.60		244 505 01--S			
			230	60	1.60	YES	244 505 90--S	YES		
			115	60	1.60		244 504 09--S			
<b>3/4 hp</b> <b>0.55 kW</b>	2-WIRE	WATER WELL	220	50	1.00		244 557 01--S		300 LBS (1500 N)	
			230	60	1.50		244 507 01--S			
			230	60	1.50	YES	244 507 90--S	YES		
		POLLUTION RECOVERY	230	60	1.50		244 507 09--S			
<b>1 hp</b> <b>0.75 kW</b>	2-WIRE	WATER WELL	220	50	1.00		244 558 12--S		650 LBS (3000 N)	
			230	60	1.40		244 508 12--S			
			230	60	1.40	YES	244 508 90--S	YES		
		POLLUTION RECOVERY	230	60	1.40		244 508 23--S			
<b>1.5 hp</b> <b>1.1 kW</b>	2-WIRE	WATER WELL	220	50	1.00		244 359 12--S		650 LBS (3000 N)	
			230	60	1.30		244 309 12--S			
			230	60	1.30	YES	244 309 90--S	YES		
		POLLUTION RECOVERY	230	60	1.30		244 309 23--S			

### NOTES:

1. Pack Designation: --S = Single Pack, available in any quantity. All 3 hp motors are single-packed.
2. Contact factory for lead time for non-stocked items.
3. Pallet packs available but not shown. Please contact customer service for availability.

# 4" Submersible Motors Super Stainless

## 4-Inch 3-wire Models

HP (KW)	DESCRIPTION						MOTOR MODEL	CONTROL BOX MODEL	STOCK STATUS	DOWNWARD THRUST RATING
	W/PH	CONSTRUCTION	VOLTS	HZ	S.F.	LEAD IN MTR				
<b>1/3 hp</b> 0.25 kW	3-WIRE	WATER WELL	115	60	1.75		214 502 44--S	280 102 49		300 LBS (1500 N)
			115	60	1.75	YES	214 502 90--S	280 102 49	YES	
			220	50	1.00		214 553 41--S	280 353 01		
			230	60	1.75		214 503 44--S	280 103 49		
			230	60	1.75	YES	214 503 90--S	280 103 49	YES	
		POLLUTION RECOVERY	115	60	1.75		214 502 49--S	280 102 49		
			230	60	1.75		214 503 49--S	280 103 49		
<b>1/2 hp</b> 0.37 kW	3-WIRE	WATER WELL	115	60	1.60		214 504 44--S	280 104 49		300 LBS (1500 N)
			115	60	1.60	YES	214 504 90--S	280 104 49	YES	
			220	50	1.00		214 555 41--S	280 355 01	YES	
			230	60	1.60		214 505 44--S	280 105 49		
			230	60	1.60	YES	214 505 90--S	280 105 49	YES	
		POLLUTION RECOVERY	115	60	1.60		214 504 49--S	280 104 49		
			230	60	1.60		214 505 49--S	280 105 49		
<b>3/4 hp</b> 0.55 kW	3-WIRE	WATER WELL	220	50	1.00		214 557 41--S	280 357 01	YES	300 LBS (1500 N)
			230	60	1.50		214 507 44--S	280 107 49		
			230	60	1.50	YES	214 507 90--S	280 107 49	YES	
		POLLUTION RECOVERY	230	60	1.50		214 507 49--S	280 107 49		
		SERIES 600M	230	60	1.50	YES	214 507 0600		YES	
<b>1 hp</b> 0.75 kW	3-WIRE	WATER WELL	220	50	1.00		214 558 19--S	280 358 01	YES	650 LBS (3000 N)
			230	60	1.40		214 508 12--S	280 108 49		
			230	60	1.40	YES	214 508 90--S	280 108 49	YES	
		POLLUTION RECOVERY	230	60	1.40		214 508 23--S	280 108 49		
		SERIES 600M	230	60	1.40	YES	214 508 0610		YES	
<b>1.5 hp</b> 1.1 kW	3-WIRE	WATER WELL	220	50	1.00		224 350 19--S	282 350 81	YES	650 LBS (3000 N)
			230	60	1.30		224 300 19--S	282 300 81	YES	
			230	60	1.30	YES	224 300 92--S	282 300 81	YES	
		POLLUTION RECOVERY	230	60	1.30		224 300 23--S	282 300 81		
		SERIES 600M	230	60	1.30	YES	224 300 0610		YES	
<b>2 hp</b> 1.5 kW	3-WIRE	WATER WELL	220	50	1.00		224 351 19--S	282 351 81	YES	650 LBS (3000 N)
			230	60	1.25		224 301 19--S	282 301 81	YES	
			230	60	1.25	YES	224 301 92--S	282 301 81	YES	
		POLLUTION RECOVERY	230	60	1.25		224 301 23--S	282 301 81		
		SERIES 600M	230	60	1.25	YES	224 301 0610		YES	
<b>3 hp</b> 2.2 kW	3-WIRE	WATER WELL	220	50	1.00		224 352 25	282 352 81	YES	900 LBS (4000 N)
			230	60	1.15		224 302 25	282 302 81		
			230	60	1.15	YES	224 302 26	282 302 81	YES	
		SERIES 600M	230	60	1.15	YES	224 302 0620		YES	

### NOTES:

1. Pack Designation: --S = Single Pack, available in any quantity. All 3 hp motors are single-packed.
2. Contact factory for lead time for non-stocked items.
3. Pallet packs available but not shown. Please contact customer service for availability.

# 4" Submersible Motors Super Stainless

## 4-Inch Three-Phase Models

HP (KW)	DESCRIPTION						MODEL	STOCK STATUS	DOWNWARD THRUST RATING	
	W/PH	CONSTRUCTION	VOLTS	HZ	S.F.	LEAD IN MTR				
<b>1/2 hp</b> 0.37 kW	3-PHASE	WATER WELL	200	60	1.60		234 501 41--S		300 LBS (1500 N)	
			200	60	1.60	YES	234 501 92--S			
			220	50	1.00		234 551 41--S			
			230	60	1.60		234 511 41--S			
			230	60	1.60	YES	234 511 92--S			
			380/415	50	1.00		234 561 31--S	YES		
			460	60	1.60		234 521 31--S			
		460	60	1.60	YES	234 521 94--S				
		POLLUTION RECOVERY	200	60	1.60		234 501 49--S			
			230	60	1.60		234 511 49--S			
460	60		1.60		234 521 49--S					
<b>3/4 hp</b> 0.55 kW	3-PHASE	WATER WELL	200	60	1.50		234 502 41--S		300 LBS (1500 N)	
			200	60	1.50	YES	234 502 92--S			
			220	50	1.00		234 552 41--S			
			230	60	1.50		234 512 41--S			
			230	60	1.50	YES	234 512 92--S			
			380/415	50	1.00		234 562 31--S	YES		
			460	60	1.50		234 522 31--S			
		460	60	1.50	YES	234 522 94--S				
		POLLUTION RECOVERY	200	60	1.50		234 502 49--S			
			230	60	1.50		234 512 49--S			
			460	60	1.50		234 522 49--S			
		SERIES 600M	230	60	1.50	YES	234 512 0600	YES		
460	60		1.50	YES	234 522 0600					
<b>1 hp</b> 0.75 kW	3-PHASE	WATER WELL	200	60	1.40		234 503 19--S		650 LBS (3000 N)	
			200	60	1.40	YES	234 503 92--S			
			220	50	1.00		234 553 41--S			
			230	60	1.40		234 513 19--S			
			230	60	1.40	YES	234 513 92--S	YES		
			380/415	50	1.00		234 563 31--S	YES		
			460	60	1.40		234 523 16--S			
		460	60	1.40	YES	234 523 94--S	YES			
		POLLUTION RECOVERY	200	60	1.40		234 503 23--S			
			230	60	1.40		234 513 23--S			
			460	60	1.40		234 523 23--S			
		SERIES 600M	230	60	1.40	YES	234 513 0610	YES		
460	60		1.40	YES	234 523 0610					

# 4" Submersible Motors Super Stainless

## 4-Inch Three-Phase Models

HP (KW)	DESCRIPTION						MODEL	STOCK STATUS	DOWNWARD THRUST RATING
	W/PH	CONSTRUCTION	VOLTS	HZ	S.F.	LEAD IN MTR			
1.5 hp 1.1 kW	3-PHASE	WATER WELL	200	60	1.30		234 504 19--S		650 LBS (3000 N)
			200	60	1.30	YES	234 504 92--S	YES	
			220	50	1.00		234 554 19--S		
			230	60	1.30		234 514 19--S		
			230	60	1.30	YES	234 514 92--S	YES	
			460/380	60/50	1.30/1.00		234 524 16--S		
			460/380	60/50	1.30/1.00	YES	234 524 94--S	YES	
			575	60	1.30		234 534 16--S		
		575	60	1.30	YES	234 534 94--S	YES		
		POLLUTION RECOVERY	200	60	1.30		234 504 23--S		
			230	60	1.30		234 514 23--S		
			460/380	60/50	1.30/1.00		234 524 23--S		
		SERIES 600M	230	60	1.30	YES	234 514 0610	YES	
			460/380	60	1.30/1.00	YES	234 524 0610		
2 hp 1.5 kW	3-PHASE	WATER WELL	200	60	1.25		234 305 16--S		650 LBS (3000 N)
			200	60	1.25	YES	234 305 92--S	YES	
			220	50	1.00		234 355 19--S		
			230	60	1.25		234 315 16--S	YES	
			230	60	1.25	YES	234 315 92--S	YES	
			460/380	60/50	1.25/1.00		234 325 16--S	YES	
			460/380	60/50	1.25/1.00	YES	234 325 94--S	YES	
			575	60	1.25		234 335 16--S		
		575	60	1.25	YES	234 335 94--S	YES		
		POLLUTION RECOVERY	200	60	1.25		234 305 23--S		
			230	60	1.25		234 315 23--S		
			460/380	60/50	1.25/1.00		234 325 23--S		
		SERIES 600M	230	60	1.25	YES	234 315 0610	YES	
			460/380	60	1.25/1.00	YES	234 325 0610		
3 hp 2.2 kW	3-PHASE	WATER WELL	200	60	1.15		234 306 25--S		900 LBS (4000 N)
			200	60	1.15	YES	234 306 26--S	YES	
			220	50	1.00		234 356 25--S		
			230	60	1.15		234 316 25--S		
			230	60	1.15	YES	234 316 26--S	YES	
			380	60	1.15		234 346 25--S		
			380	60	1.15	YES	234 346 26--S	YES	
			460/380	60/50	1.15/1.00		234 326 25--S		
			460/380	60/50	1.15/1.00	YES	234 326 26--S	YES	
			575	60	1.15		234 336 25--S		
		575	60	1.15	YES	234 336 26--S	YES		
		SERIES 600M	230	60	1.15	YES	234 316 0620		
			460/380	60	1.15/1.00	YES	234 326 0620		

### NOTES:

1. Pack Designation: --S = Single Pack, available in any quantity. All 3 hp motors are single-packed.
2. Contact factory for lead time for non-stocked items.
3. Pallet packs available but not shown. Please contact customer service for availability.

# 4" Submersible Motors High Thrust



## Application

These motors are built for dependable operation in 4" diameter or larger water wells.

## Basic Features

- Corrosion-resistant construction
- Stainless steel splined shaft
- Hermetically-sealed windings
- StatorShield™ resin system
- Filter check valve
- Water lubrication
- Kingsbury-type thrust bearing
- Pressure-equalizing diaphragm
- Sand fighting slinger
- Built-in lightning arrestors (single-phase)
- New lead assembly
- Franklin-manufactured control boxes available for single-phase motors
- UL 778 recognized (North American voltages)
- CSA certified
- ANSI/NSF 61 certified
- Industry standard NEMA mounting dimensions

## Special Options

- **316 SS Construction**  
Special construction option for corrosive applications, including acids, low pH and seawater.
- **Sand Fighter™ Construction**  
Special construction option for sandy water wells. Motors include Sand Fighter sealing system with silicon carbide mechanical shaft seal and are warranted against sand entry failure.
- **Coalbed Methane Construction**  
Special construction option for coalbed methane wells. Includes Sand Fighter sealing system, reinforced diaphragm housing to resist damage from bottom tagging and protective filter to shield diaphragm from debris.
- **Oil Stripper Construction**  
Special construction option for secondary oil recovery wells where there is a mixture of oil and water. They are also suitable for geothermal and other water well applications where high temperatures and/or high pH conditions exist. Three-phase Oil Stripper motors are equipped with Subtrol™ heat sensor for use with SubMonitor™ protection devices.

# 4" Submersible Motors High Thrust

## 4-Inch High Thrust Motor Specifications

Hz	Ph	Hp Range	kW Range	Poles	RPM	Max. Ambient Temp.	Duty Rating
60	1	1.5 - 5	1.1 - 3.7	2	3450	86 °F / 30 °C	Continuous at 0.25 ft/sec flow past motor
50	1	1.5 - 5	1.1 - 3.7	2	2875	86 °F / 30 °C	Continuous at 0.25 ft/sec flow past motor
60	3	1.5 - 10	1.1 - 7.5	2	3450	86 °F / 30 °C	Continuous at 0.25 ft/sec flow past motor
50	3	1.5 - 10	1.1 - 7.5	2	2875	86 °F / 30 °C	Continuous at 0.25 ft/sec flow past motor

**NOTE:** Not all ratings available in all construction options.

## 4-Inch High Thrust Construction Materials

Component	Construction Type		
	Standard Water Well	Coalbed Methane	Sand Fighter™
Top Castings	303 SS	303 SS	303 SS
Bottom Castings	303 SS Over Iron, Painted Cast Iron	303 SS Over Iron, Painted Cast Iron	303 SS Over Iron, Painted Cast Iron
Stator Shell	301 SS	301 SS	301 SS
Stator Ends	Low Carbon Steel	Low Carbon Steel	Low Carbon Steel
Shaft Extension	17-4 SS	17-4 SS	17-4 SS
Fasteners	300 Series SS	300 Series SS	300 Series SS
Seal Cover	Acetal	Sintered Bronze	Sintered Bronze
Seal	Nitrile Rubber Lip	Sand Fighter™ SiC/ SiC Mech Seal	Sand Fighter SiC/ SiC Mech Seal
Diaphragm	Nitrile Rubber	Nitrile Rubber	Nitrile Rubber
Diaphragm Cup	316 SS	316 SS	316 SS
Diaphragm Spring	316 SS	316 SS	316 SS
Diaphragm Cover	Gray Iron	Gray Iron	304 SS
Slinger	Nitrile Rubber	Nitrile Rubber	Nitrile Rubber
Lead Wire (or Cable)	XLPE*	XLPE*	XLPE*
Lead Potting	Epoxy	Epoxy	Epoxy
Lead Screws / Clamp	316 SS	316 SS	316 SS
Filter	Delrin & Polyester	Delrin & Polyester	Delrin & Polyester

Component	Construction Type	
	Chemical (316 STNLS)	Oil Stripper
Top Casting	316 SS	316 SS
Bottom Casting	316 SS	316 SS
Stator Shell	316 SS	316 SS
Stator Ends	316 SS	316 SS
Shaft Extension	17-4 SS	17-4 SS
Fasteners	316 SS	316 SS
Seal Cover	316 SS	316 SS
Seal	Sand Fighter SiC Mech Seal	Sand Fighter Viton®
Diaphragm	Nitrile Rubber	Viton®
Diaphragm Cup	316 SS	316 SS
Diaphragm Spring	316 SS	316 SS
Diaphragm Cover	316 SS	316 SS
Slinger	Nitrile Rubber	Viton®
Lead Wire (or Cable)	XLPE*	XLPE*
Lead Potting	Epoxy	Epoxy
Lead Screws / Clamp	316 SS	316 SS
Filter	316 SS Plug	316 SS Plug

\* Removable type, factory-installed in 60 Hz and dual frequency rated water well motors. Consult catalog for additional leads.

Specifications subject to change without notice. Contact Franklin Electric if current material types are required for bid specifications.

*Viton® is a registered trademark of DuPont Dow Elastomers.*

# 4" Submersible Motors High Thrust

## 4-Inch High Thrust Dimensions and Weights

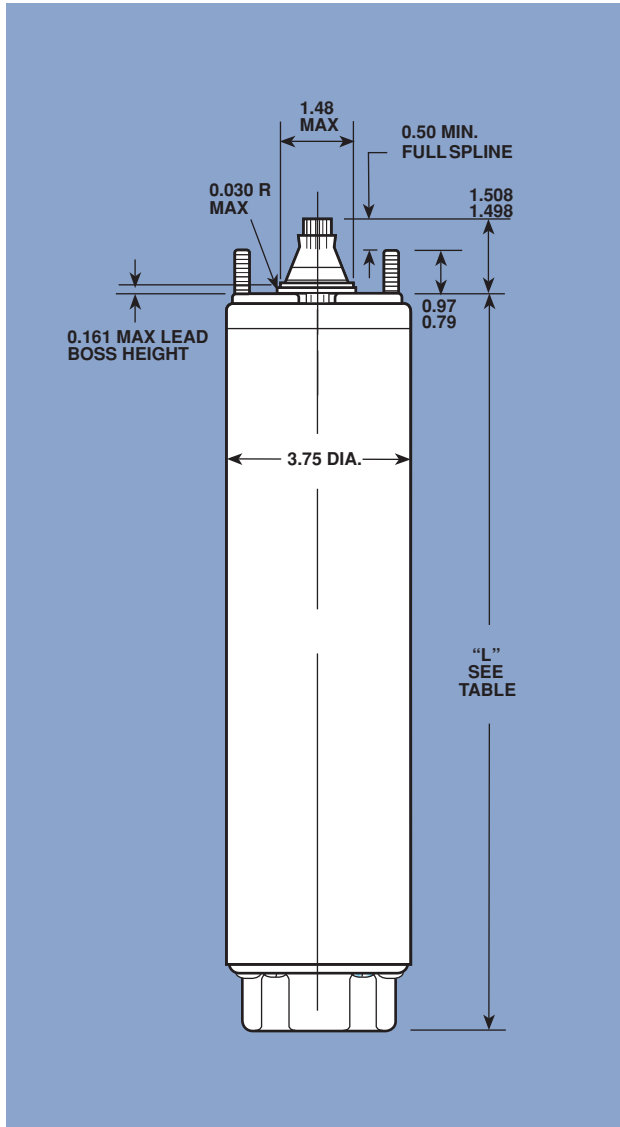

### Single-Phase Motors\*

HP	KW	"L" (inches)	SHIPPING WEIGHT		MOTOR CARTON SIZE (in inches)
			LBS	KG	
1.5	1.1	19.12	35	15.9	6 x 6 x 23
2	1.5	20.62	43	19.5	6 x 6 x 25
3	2.2	23.20	56	25.4	6 x 6 x 28
5	3.7	29.20	71	32.2	6 x 6 x 34

### Single-Phase Motors - Oil Stripper

HP	KW	"L" (inches)	SHIPPING WEIGHT		MOTOR CARTON SIZE (in inches)
			LBS	KG	
2	1.5	22.87	46	20.9	6 x 6 x 28
3	2.2	23.20	56	25.4	6 x 6 x 34
5	3.7	29.20	71	32.2	6 x 6 x 37

### Three-Phase Motors\*

HP	KW	"L" (inches)	SHIPPING WEIGHT		MOTOR CARTON SIZE (in inches)
			LBS	KG	
1.5	1.1	18.00	37	16.8	6 x 6 x 23
2	1.5	19.12	44	20.0	6 x 6 x 23
3	2.2	20.20	44	20.0	6 x 6 x 25
4	3.0	23.20	56	25.4	6 x 6 x 28
5	3.7	23.20	56	25.4	6 x 6 x 28
5.5	4.0	25.68	63	28.6	6 x 6 x 28
7.5	5.5	29.20	71	32.2	6 x 6 x 34
10	7.5	32.20	77	34.9	6 x 6 x 34

### Three-Phase Motors - Oil Stripper

HP	KW	"L" (inches)	SHIPPING WEIGHT		MOTOR CARTON SIZE (in inches)
			LBS	KG	
2	1.5	21.37	42	19.1	6 x 6 x 25
3	2.2	20.20	44	20.0	6 x 6 x 28
5	3.7	25.68	63	28.6	6 x 6 x 34
7.5	5.5	29.20	71	32.2	6 x 6 x 37

\* Represents standard and Sand Fighter™ construction models. Consult factory for Coalbed Methane and 316 SS weights and dimensions.

# 4" Submersible Motors High Thrust

## 4-Inch High Thrust Models

HP (KW)	DESCRIPTION						MODEL	STOCK STATUS	DOWNWARD THRUST RATING
	CONSTRUCTION	PH	VOLTS	HZ	S.F.	LEAD IN MTR			
<b>1.5 hp</b> <b>1.1 kW</b>	WATER WELL	1P	230	60	1.30		224 300 8600		1500 LBS (6500 N)
		3P	200	60	1.30		234 504 8600		
		3P	230	60	1.30		234 514 8600		
		3P	460/380	60/50	1.30/1.00		234 524 8600		
		3P	575	60	1.30		234 534 8600		
	316 SS	1P	230	60	1.30	YES	224 300 8502		
		3P	200	60	1.30	YES	234 504 8502		
		3P	230	60	1.30	YES	234 514 8502		
		3P	460/380	60/50	1.30/1.00	YES	234 524 8502		
		3P	575	60	1.30	YES	234 534 8502		
<b>2 hp</b> <b>1.5 kW</b>	WATER WELL	1P	230	60	1.25	YES	224 301 8602		1500 LBS (6500 N)
		3P	200	60	1.25		234 305 8600		
		3P	230	60	1.25		234 315 8600		
		3P	460/380	60/50	1.25/1.00		234 325 8600		
		3P	575	60	1.25		234 335 8600		
	SAND FIGHTER	1P	230	60	1.15	YES	224 301 8802		
	316 SS	1P	230	60	1.25	YES	224 301 8502		
		3P	200	60	1.25	YES	234 305 8502		
		3P	230	60	1.25	YES	234 315 8502		
		3P	460/380	60/50	1.25/1.00	YES	234 325 8502		
		3P	575	60	1.25	YES	234 335 8502		
	OIL STRIPPER	1P	230	60	1.25	YES	224 301 8702		
		3P	230	60	1.25	YES	234 315 8702		
		3P	460/380	60/50	1.25/1.00	YES	234 325 8702		

# 4" Submersible Motors High Thrust

## 4-Inch High Thrust Models

HP (KW)	DESCRIPTION						MODEL	STOCK STATUS	DOWNWARD THRUST RATING
	CONSTRUCTION	PH	VOLTS	HZ	S.F.	LEAD IN MTR			
<b>3 hp</b> <b>2.2 kW</b>	WATER WELL	1P	220	50	1.00		224 352 8600		1500 LBS (6500 N)
		1P	230	60	1.15		224 302 8600		
		1P	230	60	1.15	YES	224 302 8602		
		3P	200	60	1.15		234 306 8600		
		3P	200	60	1.15	YES	234 306 8602		
		3P	220	50	1.00		234 356 8600		
		3P	230	60	1.15		234 316 8600		
		3P	230	60	1.15	YES	234 316 8602		
		3P	380	60	1.15		234 346 8600		
		3P	380	60	1.15	YES	234 346 8602		
		3P	460/380	60/50	1.15/1.00		234 326 8600		
		3P	460/380	60/50	1.15/1.00	YES	234 326 8602		
		3P	575	60	1.15		234 336 8600		
		3P	575	60	1.15	YES	234 336 8602		
	COALBEAD METHANE	3P	200	60	1.15	YES	234 306 8902		
		3P	230	60	1.15	YES	234 316 8902		
		3P	460/380	60/50	1.15/1.00	YES	234 326 8902	YES	
		3P	575	60	1.15	YES	234 336 8902		
		3P	380	60	1.15	YES	234 346 8902		
	SAND FIGHTER	1P	230	60	1.15	YES	224 302 8802	YES	
		3P	200	60	1.15	YES	234 306 8802		
		3P	230	60	1.15	YES	234 316 8802	YES	
		3P	460/380	60/50	1.15/1.00	YES	234 326 8802	YES	
		3P	575	60	1.15	YES	234 336 8802		
		3P	380	60	1.15	YES	234 346 8802		
	SERIES 600M	1P	230	60	1.15	YES	224 302 0630	YES	
		3P	230	60	1.15	YES	234 316 0630	YES	
		3P	460/380	60	1.15/1.00	YES	234 326 0630		
	316 SS	1P	230	60	1.15	YES	224 302 8502		
		3P	200	60	1.15	YES	234 306 8502		
3P		230	60	1.15	YES	234 316 8502			
3P		460/380	60/50	1.15/1.00	YES	234 326 8502			
3P		575	60	1.15	YES	234 336 8502			
OIL STRIPPER	1P	230	60	1.15	YES	224 302 8702			
	3P	230	60	1.15	YES	234 316 8702			
	3P	460/380	60/50	1.15/1.00	YES	234 326 8702			
<b>4 hp</b> <b>3 kW</b>	WATER WELL	3P	460/415-380	60/50	1.15/1.00		234 395 8600		
		3P	460/415-380	60/50	1.15/1.00	YES	234 395 8602		

# 4" Submersible Motors High Thrust

## 4-Inch High Thrust Models

HP (KW)	DESCRIPTION						MODEL	STOCK STATUS	DOWNWARD THRUST RATING
	CONSTRUCTION	PH	VOLTS	HZ	S.F.	LEAD IN MTR			
<b>5 hp 3.7 kW</b>	WATER WELL	1P	220	50	1.00		224 353 8600	YES	1500 LBS (6500 N)
		1P	230	60	1.15		224 303 8600		
		1P	230	60	1.15	YES	224 303 8602	YES	
		3P	200	60	1.15		234 307 8600		
		3P	200	60	1.15	YES	234 307 8602	YES	
		3P	220	50	1.00		234 357 8600		
		3P	230	60	1.15		234 317 8600		
		3P	230	60	1.15	YES	234 317 8602	YES	
		3P	380	60	1.15		234 347 8600		
		3P	380	60	1.15	YES	234 347 8602		
		3P	460/380	60/50	1.15/1.00		234 327 8600	YES	
		3P	460/380	60/50	1.15/1.00	YES	234 327 8602	YES	
		3P	575	60	1.15		234 337 8600		
		3P	575	60	1.15	YES	234 337 8602	YES	
	COALBED METHANE	3P	200	60	1.15	YES	234 307 8904		
		3P	230	60	1.15	YES	234 317 8904		
		3P	460/380	60/50	1.15/1.00	YES	234 327 8904	YES	
		3P	575	60	1.15	YES	234 337 8904		
		3P	380	60	1.15	YES	234 347 8904		
	SAND FIGHTER	1P	230	60	1.15	YES	224 303 8802	YES	
		3P	200	60	1.15	YES	234 307 8802		
		3P	230	60	1.15	YES	234 317 8802	YES	
		3P	460/380	60/50	1.15/1.00	YES	234 327 8802	YES	
		3P	575	60	1.15	YES	234 337 8802		
		3P	380	60	1.15	YES	234 347 8802		
	SERIES 600M	1P	230	60	1.15	YES	224 303 0630	YES	
		3P	230	60	1.15	YES	234 317 0630	YES	
		3P	460/380	60	1.15/1.00	YES	234 327 0630		
	316 SS	1P	230	60	1.15	YES	224 303 8502		
		3P	200	60	1.15	YES	234 307 8502		
3P		230	60	1.15	YES	234 317 8502			
3P		460/380	60/50	1.15/1.00	YES	234 327 8502			
3P		575	60	1.15	YES	234 337 8502			
OIL STRIPPER	1P	230	60	1.15	YES	224 303 8702			
	3P	230	60	1.15	YES	234 317 8702			
	3P	460/380	60/50	1.15/1.00	YES	234 327 8702			
<b>5.5 hp 4 kW</b>	WATER WELL	3P	460/380	60/50	1.15/1.00		234 397 8600		1500 LBS (6500 N)
		3P	460/380	60/50	1.15/1.00	YES	234 397 8602		

# 4" Submersible Motors High Thrust

## 4-Inch High Thrust Models

HP (KW)	DESCRIPTION						MODEL	STOCK STATUS	DOWNWARD THRUST RATING
	CONSTRUCTION	PH	VOLTS	HZ	S.F.	LEAD IN MTR			
<b>7.5 hp 5.5 kW</b>	WATER WELL	3P	200	60	1.15		234 308 8600		1500 LBS (6500 N)
		3P	200	60	1.15	YES	234 308 8602	YES	
		3P	220	50	1.00		234 358 8600		
		3P	230	60	1.15		234 318 8600		
		3P	230	60	1.15	YES	234 318 8602	YES	
		3P	380	60	1.15		234 348 8600		
		3P	380	60	1.15	YES	234 348 8602		
		3P	460/380	60/50	1.15/1.00		234 328 8600	YES	
		3P	460/380	60/50	1.15/1.00	YES	234 328 8602	YES	
		3P	575	60	1.15		234 338 8600		
	3P	575	60	1.15	YES	234 338 8602	YES		
	COALBED METHANE	3P	200	60	1.15	YES	234 308 8904		
		3P	230	60	1.15	YES	234 318 8904		
		3P	460/380	60/50	1.15/1.00	YES	234 328 8904	YES	
		3P	575	60	1.15	YES	234 338 8904		
		3P	380	60	1.15	YES	234 348 8904		
	SAND FIGHTER	3P	200	60	1.15	YES	234 308 8802		
		3P	230	60	1.15	YES	234 318 8802	YES	
		3P	460/380	60/50	1.15/1.00	YES	234 328 8802	YES	
		3P	575	60	1.15	YES	234 338 8802		
		3P	380	60	1.15	YES	234 348 8802		
	316 SS	3P	200	60	1.15	YES	234 308 8502		
		3P	230	60	1.15	YES	234 318 8502		
		3P	460/380	60/50	1.15/1.00	YES	234 328 8502		
3P		575	60	1.15	YES	234 338 8502			
OIL STRIPPER	3P	230	60	1.15	YES	234 318 8702			
	3P	460/380	60/50	1.15/1.00	YES	234 328 8702			
<b>10 hp 7.5 kW</b>	WATER WELL	3P	380	60	1.15		234 549 8600		
		3P	460/380	60/50	1.15/1.00		234 595 8600	YES	
		3P	575	60	1.15		234 598 8600	YES	
	COALBED METHANE	3P	380	60	1.15	YES	234 549 8902		
		3P	460/380	60/50	1.15/1.00	YES	234 595 8902	YES	
		3P	575	60	1.15	YES	234 598 8902		
	SAND FIGHTER	3P	380	60	1.15	YES	234 549 8802		
		3P	460/380	60/50	1.15/1.00	YES	234 595 8802	YES	
		3P	575	60	1.15	YES	234 598 8802		

# 4" Submersible Motors Leads

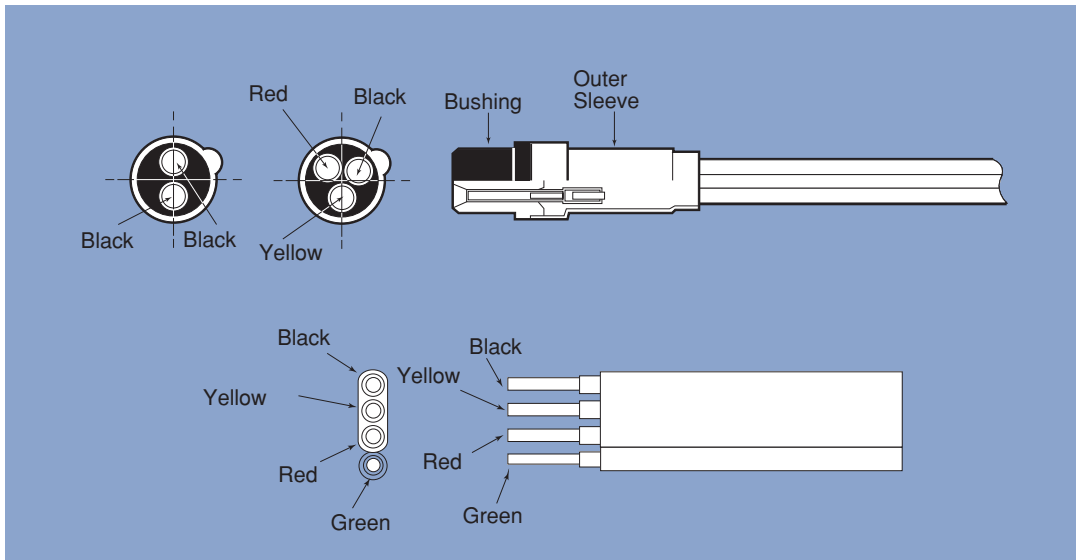

## 4-Inch Motor Leads And Cables

WIRE	CONSTRUCTION	MATERIAL	LEAD LENGTH		WIRE SIZE	GROUNDED	JAM NUT MODEL	CLAMP STYLE MODEL
			IN / FT	M				
<b>2W</b>	INDIVIDUAL	NITRILE*	48 in	1.2	AWG 14	NO	152 328 905	N/A
	INDIVIDUAL	NITRILE*	100 in	2.5	AWG 14	NO	152 328 906	N/A
	INDIVIDUAL	XLPE	48 in	1.2	AWG 14	YES	152 552 905	N/A
	INDIVIDUAL	XLPE	100 in	2.5	AWG 14	YES	152 552 906	N/A
<b>3W</b>	INDIVIDUAL	XLPE	48 in	1.2	AWG 14	YES	152 553 905	152 735 911
	INDIVIDUAL	XLPE	100 in	2.5	AWG 14	YES	152 553 906	152 735 941
	INDIVIDUAL	NITRILE*	48 in	1.2	AWG 14	NO	152 255 901	N/A
	INDIVIDUAL	NITRILE*	100 in	2.5	AWG 14	NO	152 255 902	152 744 902
	INDIVIDUAL	NITRILE*	160 in	4.0	AWG 14	NO	152 255 904	152 744 904
	INDIVIDUAL	NITRILE*	30 ft	9.1	AWG 14	NO	152 255 906	152 744 906
	INDIVIDUAL	NITRILE*	50 ft	15.2	AWG 14	NO	152 255 907	152 744 907
	INDIVIDUAL	NITRILE*	100 ft	30.5	AWG 14	NO	152 255 910	152 744 910
	INDIVIDUAL	NITRILE*	150 ft	45.7	AWG 14	NO	152 255 912	152 744 912
	INDIV / DBL CONN	XLPE	48 in	1.2	AWG 14	YES	152 570 901	N/A
INDIV / DBL CONN	XLPE	100 in	2.5	AWG 14	YES	152 570 902	N/A	

\* Nitrile material not for use in potable water.

### NOTES:

1. Refer to Franklin Application Installation Maintenance (AIM) Manual for accurate cable sizing.
2. MOTOR WARRANTY IS VOID if Franklin-supplied leads are not used.

# 6" Submersible Motors Standard



## Applications

These motors are built for dependable operation in 6" diameter or larger water wells.

## Basic Features

- Double flanged NEMA mounting design
- Stainless steel splined shaft
- StatorShield™ Franklin's six feature encapsulation system
- High capacity Kingsbury type water lubricated thrust bearing
- Factory filled with Franklin's non-toxic water soluble fill solution
- Field replaceable lead using Franklin's exclusive Water Bloc™ technology
- Full 3450 rpm 60 Hz design point
- External sand slinger on shaft
- Mechanical face seal at shaft exit
- Copper bar rotor
- All models variable frequency drive (VFD) approved
- Single-phase models must be used with a Franklin Electric control box

## Special Options

- Sand Fighter™ Models are equipped with:
  - Franklin's Exclusive Sand Fighter Sealing System for sand or other abrasives well water.
  - Franklin's Exclusive on winding SubTrol™ heat sensor for use with SubMonitor™.
- 316 Stainless Steel construction models come standard with:
  - Franklin's Exclusive Sand Fighter Sealing System for sand or other abrasives well water.
  - Franklin's Exclusive on winding SubTrol heat sensor for use with SubMonitor™.
- SubMonitor is a state-of-the-art electronic motor overload that is sold separately.
  - Mounts in the above ground panel requiring no additional wiring to the motor.
  - User friendly, field proven.
  - Protection monitors for balanced power, overload, underload, overheating, rapid cycling and more.
  - Can be used with or without a SubTrol heat sensor.
  - Supplies superior heat protection when manufactured with the SubTrol heat sensor.

Consult factory for other voltage, hertz and horsepower ratings not listed in this catalog.

Specifications are subject to change without notice. Contact Franklin Electric if current materials are required for bid specifications.

# 6" Submersible Motors Standard

## Standard 6-Inch Motor Specifications

Hz	Ph	Hp Range	kW Range	Poles	RPM	Max. Ambient Temp.	Duty Rating
60	1	5 - 15	3.7 - 11	2	3450	86 °F / 30 °C	Continuous at 0.5 ft/sec flow past motor
60	3	5 - 40	3.7 - 30	2	3450	86 °F / 30 °C	Continuous at 0.5 ft/sec flow past motor
60	3	50 - 60	37 - 45	2	3450	122 °F / 50 °C	Continuous at 0.5 ft/sec flow past motor
50	1	5 - 15	3.7 - 11	2	2875	86 °F / 30 °C	Continuous at 0.5 ft/sec flow past motor
50	3	5 - 40	3.7 - 30	2	2875	86 °F / 30 °C	Continuous at 0.5 ft/sec flow past motor
50	3	50 - 60	37 - 45	2	2875	122 °F / 50 °C	Continuous at 0.5 ft/sec flow past motor

## 6-Inch Construction Materials

Component	Construction Type		
	Standard Water Well	Sand Fighter™	Corrosion Resistant (316 SS)
UL Insulation Class Rating	Class F	Per Standard Water Well	Per Standard Water Well
Motor Ambient Temperature Rating	86 °F / 30 °C (5-40 hp) 122 °F / 50 °C (50-60 hp)	Per Standard Water Well	Per Standard Water Well
Stator Resin Type	FE Standard (5-40 hp) FE Hi-Temp (50-60 hp)	Per Standard Water Well	Per Standard Water Well
Motor Fill Solution (Water Soluble/Non-Toxic)	FES91	Per Standard Water Well	Per Standard Water Well
Top End Bell & Thrust Housing	Epoxy Coated Gray Iron	Per Standard Water Well	316 SS
On Winding SubTrol™ heat sensor	No (5-40 hp) Yes (50-60 hp)	Yes	Yes
Stator Shell	300 SS Series	Per Standard Water Well	316 SS
Stator Ends	Carbon Steel	Per Standard Water Well	316 SS
Shaft Extension	300 SS Series (5-30 hp) 17-4 SS (40-60 hp)	Per Standard Water Well	17-4 SS
Bushing	Bronze	Per Standard Water Well	316 SS
Bushing Retainer	300 SS Series	Per Standard Water Well	316 SS
Shaft Mechanical Seal	Carbon Ceramic Seal (5-40 hp) Sand Fighter™ Seal System (50-60 hp)	Sand Fighter Seal System	Sand Fighter Seal System
Mechanical Seal Rubber Components	Nitrile (5-40 hp) Viton® (50-60 hp)	Per Standard Water Well	Per Standard Water Well
Diaphragm Material	Nitrile (5-40 hp) Viton® (50-60 hp)	Per Standard Water Well	Per Standard Water Well
Diaphragm Plate	300 SS Series	Per Standard Water Well	316 SS
Diaphragm Spring	300 SS Series	Per Standard Water Well	25-6 MO SS
Shaft Slinger	Nitrile (5-40 hp) Viton® (50-60 hp)	Per Standard Water Well	Nitrile
Lead Wire	XLPE	Per Standard Water Well	Per Standard Water Well
Lead Potting	Epoxy	Per Standard Water Well	Per Standard Water Well
Lead Jam Nut	Brass	Per Standard Water Well	316 SS
Thrust Bearing Rating (86 °F / 30 °C)	3500 lbs (5-30 hp) 6000 lbs (40-60 hp)	Per Standard Water Well	Per Standard Water Well
Method Of Connecting System Ground To Motor	Ground Wire In Power Lead Connector	Per Standard Water Well	Per Standard Water Well

Specifications subject to change without notice. Contact Franklin Electric if current material types are required for bid specifications.

Viton® is a registered trademark of DuPont Dow Elastomers.

# 6" Submersible Motors Standard

## 6-Inch Dimensions and Weights

### Standard Single-Phase Water Well

HP	KW	"L" (inches)	SHIPPING WEIGHT		MOTOR CARTON SIZE (in inches)
			LBS	KG	
5	3.7	25.4	110	50	7.50 x 10.75 x 34.50
7.5	5.5	28	123	56	7.50 x 10.75 x 34.50
10	7.5	30.6	141	64	7.50 x 10.75 x 37.00
15	11	33.1	154	70	7.50 x 10.75 x 42.25

### Standard Three-Phase Water Well

HP	KW	"L" (inches)	SHIPPING WEIGHT		MOTOR CARTON SIZE (in inches)
			LBS	KG	
5	3.7	22.9	101	46	7.50 x 10.75 x 34.50
7.5	5.5	24.2	108	49	7.50 x 10.75 x 34.50
10	7.5	25.4	116	53	7.50 x 10.75 x 34.50
15	11	28.0	129	59	7.50 x 10.75 x 34.50
20	15	30.6	145	66	7.50 x 10.75 x 37.00
25	18.5	33.1	156	71	7.50 x 10.75 x 42.25
30	22	35.7	174	79	7.50 x 10.75 x 42.25
40	30	40.8	202	92	7.50 x 10.75 x 47.25
50	37	55.3	300	136	8.75 x 10.50 x 71.75
60	45	61.3	330	150	8.75 x 10.50 x 71.75

6-Lead Y-Δ models available. (Add 5 lbs to shipping weight.)

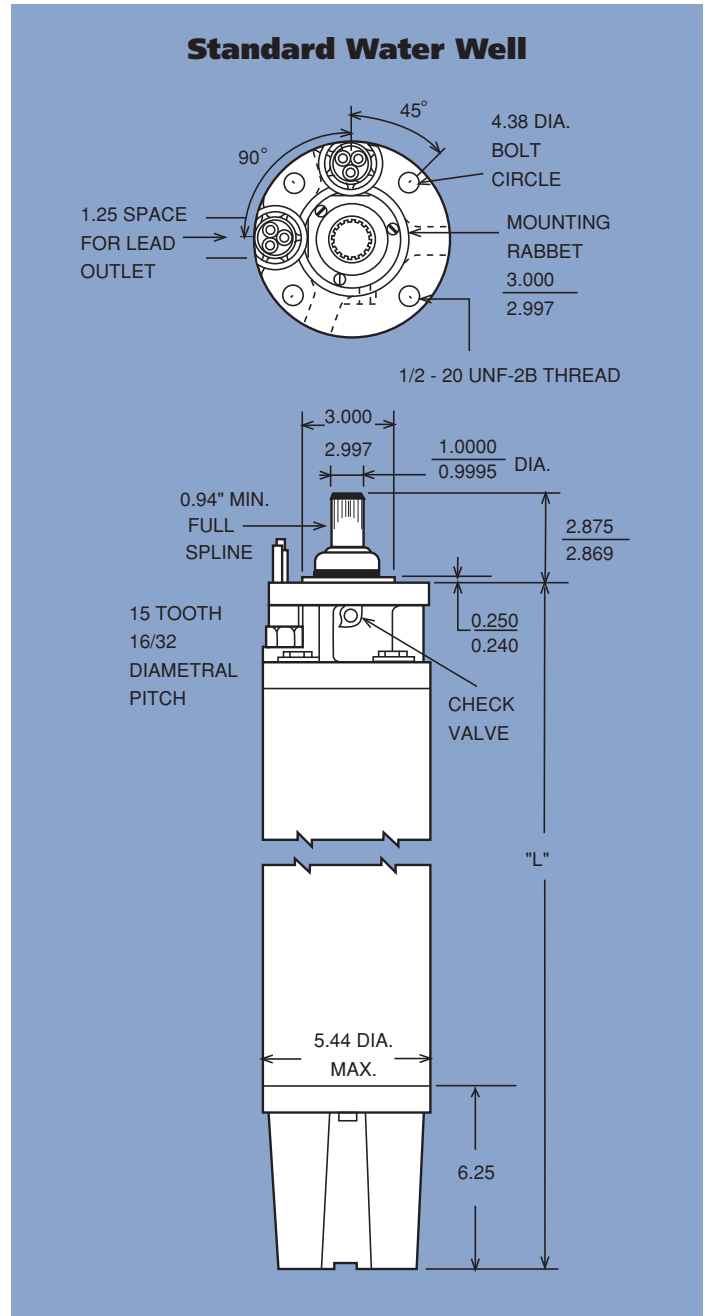

# 6" Submersible Motors Standard

## 316 SS Shell Single-Phase 3-Lead

HP	KW	"L" (inches)	SHIPPING WEIGHT		MOTOR CARTON SIZE (in inches)
			LBS	KG	
5	3.7	25.4	110	50	7.50 x 10.75 x 34.50
7.5	5.5	28	123	56	7.50 x 10.75 x 34.50
10	7.5	30.6	141	64	7.50 x 10.75 x 37.00
15	11	33.1	154	70	7.50 x 10.75 x 42.25

## 316 SS Shell 3-Lead

HP	KW	"L" (inches)	SHIPPING WEIGHT		MOTOR CARTON SIZE (in inches)
			LBS	KG	
5	3.7	22.5	101	46	7.50 x 10.75 x 34.50
7.5	5.5	23.8	108	49	7.50 x 10.75 x 34.50
10	7.5	25.0	116	53	7.50 x 10.75 x 34.50
15	11	27.6	129	59	7.50 x 10.75 x 34.50
20	15	30.2	145	66	7.50 x 10.75 x 37.00
25	18.5	32.7	156	71	7.50 x 10.75 x 42.25
30	22	35.3	174	79	7.50 x 10.75 x 42.25
40	30	40.4	202	92	7.50 x 10.75 x 47.25
50	37	59.2	300	136	8.75 x 10.50 x 71.75
60	45	65.2	330	150	8.75 x 10.50 x 71.75

6-Lead Y-Δ models available. (Add 5 lbs to shipping weight.)

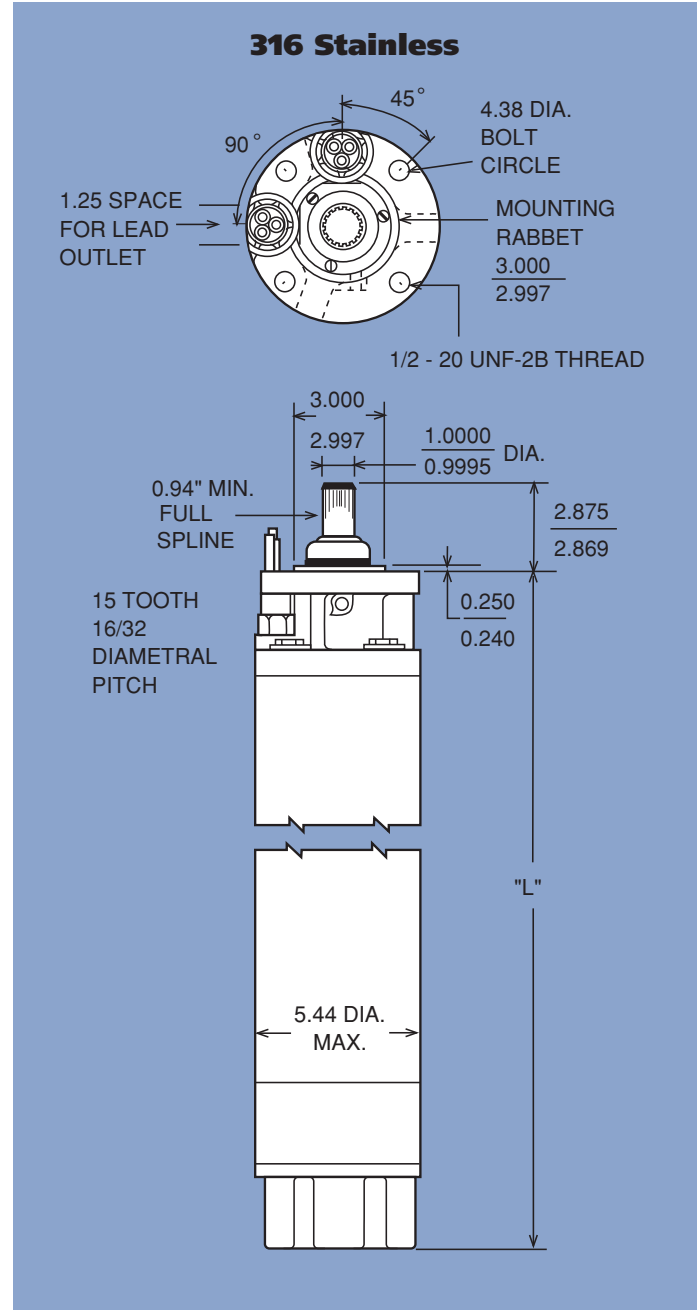

# 6" Submersible Motors Standard

## 6-Inch Models

HP (KW)	CONSTRUCTION	DESCRIPTION							MODEL	STOCK STATUS
		PH	VOLTS	HZ	SUBTROL HEAT SENSOR	S.F.	# LEADS	WIRE SIZE (AWG)		
5 hp 3.7 kW	WATER WELL	1P	230	60	Not Available	1.15	3	#10 w/GND	226 110 90	YES
		3P	200-208	60	Not Available	1.15	3	#10 w/GND	236 650 90	YES
		3P	220	50	Not Available	1.00	3	#10 w/GND	236 680 90	
		3P	220	50	Not Available	1.00	6-90°	#10 w/GND	236 670 90	
		3P	230	60	Not Available	1.15	3	#10 w/GND	236 600 90	YES
		3P	230	60	Not Available	1.15	6-90°	#10 w/GND	236 720 90	
		3P	380	60	Not Available	1.15	3	#10 w/GND	236 660 90	
		3P	380	60	Not Available	1.15	6-90°	#10 w/GND	236 780 90	
		3P	415	50	Not Available	1.00	3	#10 w/GND	236 690 90	
		3P	460/380-415	60/50	Not Available	1.15/1.00	3	#10 w/GND	236 610 90	YES
		3P	460/380-415	60/50	Not Available	1.15/1.00	6-90°	#10 w/GND	236 710 90	
		3P	575	60	Not Available	1.15	3	#10 w/GND	236 620 90	
	SAND FIGHTER	1P	230	60	Not Available	1.15	3	#10 w/GND	226 110 80	YES
		3P	200-208	60	YES	1.15	3	#10 w/GND	236 650 81	YES
		3P	220	50	YES	1.00	3	#10 w/GND	236 680 81	
		3P	220	50	YES	1.00	6-90°	#10 w/GND	236 670 81	
		3P	230	60	YES	1.15	3	#10 w/GND	236 600 81	YES
		3P	230	60	YES	1.15	6-90°	#10 w/GND	236 720 81	
		3P	380	60	YES	1.15	3	#10 w/GND	236 660 81	
		3P	380	60	YES	1.15	6-90°	#10 w/GND	236 780 81	
		3P	415	50	YES	1.00	3	#10 w/GND	236 690 81	
		3P	460/380-415	60/50	YES	1.15/1.00	3	#10 w/GND	236 610 81	YES
		3P	460/380-415	60/50	YES	1.15/1.00	6-90°	#10 w/GND	236 710 81	
		3P	575	60	YES	1.15	3	#10 w/GND	236 620 81	YES
	316 SS	1P	230	60	Not Available	1.15	3	#10 w/GND	226 110 39	
		3P	200-208	60	YES	1.15	3	#10 w/GND	236 650 40	
		3P	220	50	YES	1.00	3	#10 w/GND	236 680 40	
		3P	220	50	YES	1.00	6-90°	#10 w/GND	236 670 40	
		3P	230	60	YES	1.15	3	#10 w/GND	236 600 40	YES
		3P	230	60	YES	1.15	6-90°	#10 w/GND	236 720 40	
		3P	380	60	YES	1.15	3	#10 w/GND	236 660 40	
		3P	380	60	YES	1.15	6-90°	#10 w/GND	236 780 40	
		3P	415	50	YES	1.15	3	#10 w/GND	236 690 40	
3P		460/380-415	60/50	YES	1.15/1.00	3	#10 w/GND	236 610 40	YES	
3P		460/380-415	60/50	YES	1.15/1.00	6-90°	#10 w/GND	236 710 40		
3P		575	60	YES	1.15	3	#10 w/GND	236 620 40		

# 6" Submersible Motors Standard

## 6-Inch Models

HP (KW)	CONSTRUCTION	DESCRIPTION							MODEL	STOCK STATUS
		PH	VOLTS	HZ	SUBTROL HEAT SENSOR	S.F.	# LEADS	WIRE SIZE (AWG)		
<b>7.5 hp 5.5 kW</b>	WATER WELL	1P	230	60	Not Available	1.15	3	#10 w/GND	226 111 90	YES
		3P	200-208	60	Not Available	1.15	3	#10 w/GND	236 651 90	YES
		3P	220	50	Not Available	1.00	3	#10 w/GND	236 681 90	
		3P	220	50	Not Available	1.00	6-90°	#10 w/GND	236 671 90	
		3P	230	60	Not Available	1.15	3	#10 w/GND	236 601 90	YES
		3P	230	60	Not Available	1.15	6-90°	#10 w/GND	236 721 90	
		3P	380	60	Not Available	1.15	3	#10 w/GND	236 661 90	YES
		3P	380	60	Not Available	1.15	6-90°	#10 w/GND	236 781 90	
		3P	415	50	Not Available	1.00	3	#10 w/GND	236 691 90	
		3P	460/380-415	60/50	Not Available	1.15/1.00	3	#10 w/GND	236 611 90	YES
		3P	460/380-415	60/50	Not Available	1.15/1.00	6-90°	#10 w/GND	236 711 90	YES
		3P	575	60	Not Available	1.15	3	#10 w/GND	236 621 90	
	SAND FIGHTER	1P	230	60	Not Available	1.15	3	#10 w/GND	226 111 80	YES
		3P	200-208	60	YES	1.15	3	#10 w/GND	236 651 81	YES
		3P	220	50	YES	1.00	3	#10 w/GND	236 681 81	
		3P	220	50	YES	1.00	6-90°	#10 w/GND	236 671 81	
		3P	230	60	YES	1.15	3	#10 w/GND	236 601 81	YES
		3P	230	60	YES	1.15	6-90°	#10 w/GND	236 721 81	
		3P	380	60	YES	1.15	3	#10 w/GND	236 661 81	
		3P	380	60	YES	1.15	6-90°	#10 w/GND	236 781 81	
		3P	415	50	YES	1.00	3	#10 w/GND	236 691 81	
		3P	460/380-415	60/50	YES	1.15/1.00	3	#10 w/GND	236 611 81	YES
		3P	460/380-415	60/50	YES	1.15/1.00	6-90°	#10 w/GND	236 711 81	
		3P	575	60	YES	1.15	3	#10 w/GND	236 621 81	YES
	316 SS	1P	230	60	Not Available	1.15	3	#10 w/GND	226 111 39	
		3P	200-208	60	YES	1.15	3	#10 w/GND	236 651 40	
		3P	220	50	YES	1.00	3	#10 w/GND	236 681 40	
		3P	220	50	YES	1.00	6-90°	#10 w/GND	236 671 40	
		3P	230	60	YES	1.15	3	#10 w/GND	236 601 40	YES
		3P	230	60	YES	1.15	6-90°	#10 w/GND	236 721 40	
		3P	380	60	YES	1.15	3	#10 w/GND	236 661 40	
		3P	380	60	YES	1.15	6-90°	#10 w/GND	236 781 40	
		3P	415	50	YES	1.00	3	#10 w/GND	236 691 81	
		3P	460/380-415	60/50	YES	1.15/1.00	3	#10 w/GND	236 611 40	YES
		3P	460/380-415	60/50	YES	1.15/1.00	6-90°	#10 w/GND	236 711 40	
		3P	575	60	YES	1.15	3	#10 w/GND	236 621 40	

# 6" Submersible Motors Standard

## 6-Inch Models

HP (KW)	CONSTRUCTION	DESCRIPTION							MODEL	STOCK STATUS
		PH	VOLTS	HZ	SUBTROL HEAT SENSOR	S.F.	# LEADS	WIRE SIZE (AWG)		
<b>10 hp 7.5 kW</b>	WATER WELL	1P	230	60	Not Available	1.15	3	#10 w/GND	226 112 90	YES
		3P	200-208	60	Not Available	1.15	3	#10 w/GND	236 652 90	YES
		3P	220	50	Not Available	1.00	3	#10 w/GND	236 682 90	
		3P	220	50	Not Available	1.00	6-90°	#10 w/GND	236 672 90	
		3P	230	60	Not Available	1.15	3	#10 w/GND	236 602 90	YES
		3P	230	60	Not Available	1.15	6-90°	#10 w/GND	236 722 90	
		3P	380	60	Not Available	1.15	3	#10 w/GND	236 662 90	YES
		3P	380	60	Not Available	1.15	6-90°	#10 w/GND	236 782 90	
		3P	415	50	Not Available	1.00	3	#10 w/GND	236 692 90	
		3P	460/380-415	60/50	Not Available	1.15/1.00	3	#10 w/GND	236 612 90	YES
		3P	460/380-415	60/50	Not Available	1.15/1.00	6-90°	#10 w/GND	236 712 90	YES
		3P	575	60	Not Available	1.15	3	#10 w/GND	236 622 90	
		SAND FIGHTER	1P	230	60	Not Available	1.15	3	#10 w/GND	226 112 80
	3P		200-208	60	YES	1.15	3	#10 w/GND	236 652 81	YES
	3P		220	50	YES	1.00	3	#10 w/GND	236 682 81	
	3P		220	50	YES	1.00	6-90°	#10 w/GND	236 672 81	
	3P		230	60	YES	1.15	3	#10 w/GND	236 602 81	YES
	3P		230	60	YES	1.15	6-90°	#10 w/GND	236 722 81	
	3P		380	60	YES	1.15	3	#10 w/GND	236 662 81	
	3P		380	60	YES	1.15	6-90°	#10 w/GND	236 782 81	
	3P		415	50	YES	1.00	3	#10 w/GND	236 692 81	
	3P		460/380-415	60/50	YES	1.15/1.00	3	#10 w/GND	236 612 81	YES
	3P		460/380-415	60/50	YES	1.15/1.00	6-90°	#10 w/GND	236 712 81	
	3P		575	60	YES	1.15	3	#10 w/GND	236 622 81	YES
	316 SS		1P	230	60	Not Available	1.15	3	#10 w/GND	226 112 39
		3P	200-208	60	YES	1.15	3	#10 w/GND	236 652 40	
		3P	220	50	YES	1.00	3	#10 w/GND	236 682 40	
		3P	220	50	YES	1.00	6-90°	#10 w/GND	236 672 40	
		3P	230	60	YES	1.15	3	#10 w/GND	236 602 40	YES
		3P	230	60	YES	1.15	6-90°	#10 w/GND	236 722 40	
		3P	380	60	YES	1.15	3	#10 w/GND	236 662 40	
		3P	380	60	YES	1.15	6-90°	#10 w/GND	236 782 40	
		3P	415	50	YES	1.00	3	#10 w/GND	236 692 40	
		3P	460/380-415	60/50	YES	1.15/1.00	3	#10 w/GND	236 612 40	YES
		3P	460/380-415	60/50	YES	1.15/1.00	6-90°	#10 w/GND	236 712 40	
		3P	575	60	YES	1.15	3	#10 w/GND	236 622 40	

# 6" Submersible Motors Standard

## 6-Inch Models

HP (KW)	CONSTRUCTION	DESCRIPTION							MODEL	STOCK STATUS
		PH	VOLTS	HZ	SUBTROL HEAT SENSOR	S.F.	# LEADS	WIRE SIZE (AWG)		
15 hp 11 kW	WATER WELL	1P	230	60	Not Available	1.15	3	#10 w/GND	226 113 90	YES
		3P	200-208	60	Not Available	1.15	3	#10 w/GND	236 653 90	YES
		3P	220	50	Not Available	1.00	3	#10 w/GND	236 683 90	
		3P	220	50	Not Available	1.00	6-90°	#10 w/GND	236 673 90	
		3P	230	60	Not Available	1.15	3	#10 w/GND	236 603 90	YES
		3P	230	60	Not Available	1.15	6-90°	#10 w/GND	236 723 90	YES
		3P	380	60	Not Available	1.15	3	#10 w/GND	236 663 90	YES
		3P	380	60	Not Available	1.15	6-90°	#10 w/GND	236 783 90	
		3P	415	50	Not Available	1.00	3	#10 w/GND	236 693 90	
		3P	460/380-415	60/50	Not Available	1.15/1.00	3	#10 w/GND	236 613 90	YES
		3P	460/380-415	60/50	Not Available	1.15/1.00	6-90°	#10 w/GND	236 713 90	YES
		3P	575	60	Not Available	1.15	3	#10 w/GND	236 623 90	
		SAND FIGHTER	1P	230	60	Not Available	1.15	3	#10 w/GND	226 113 80
	3P		200-208	60	YES	1.15	3	#10 w/GND	236 653 81	YES
	3P		220	50	YES	1.00	3	#10 w/GND	236 683 81	
	3P		220	50	YES	1.00	6-90°	#10 w/GND	236 673 81	
	3P		230	60	YES	1.15	3	#10 w/GND	236 603 81	YES
	3P		230	60	YES	1.15	6-90°	#10 w/GND	236 723 81	
	3P		380	60	YES	1.15	3	#10 w/GND	236 663 81	
	3P		380	60	YES	1.15	6-90°	#10 w/GND	236 783 81	
	3P		415	50	YES	1.00	3	#10 w/GND	236 693 81	
	3P		460/380-415	60/50	YES	1.15/1.00	3	#10 w/GND	236 613 81	YES
	3P		460/380-415	60/50	YES	1.15/1.00	6-90°	#10 w/GND	236 713 81	
	3P		575	60	YES	1.15	3	#10 w/GND	236 623 81	YES
	316 SS		1P	230	60	Not Available	1.15	3	#10 w/GND	226 113 39
		3P	200-208	60	YES	1.15	3	#10 w/GND	236 653 40	
		3P	220	50	YES	1.00	3	#10 w/GND	236 683 40	
		3P	220	50	YES	1.00	6-90°	#10 w/GND	236 673 40	
		3P	230	60	YES	1.15	3	#10 w/GND	236 603 40	YES
		3P	230	60	YES	1.15	6-90°	#10 w/GND	236 723 40	
		3P	380	60	YES	1.15	3	#10 w/GND	236 663 40	
		3P	380	60	YES	1.15	6-90°	#10 w/GND	236 783 40	
		3P	415	50	YES	1.00	3	#10 w/GND	236 693 40	
		3P	460/380-415	60/50	YES	1.15/1.00	3	#10 w/GND	236 613 40	YES
		3P	460/380-415	60/50	YES	1.15/1.00	6-90°	#10 w/GND	236 713 40	
		3P	575	60	YES	1.15	3	#10 w/GND	236 623 40	

# 6" Submersible Motors Standard

## 6-Inch Models

HP (KW)	CONSTRUCTION	DESCRIPTION							MODEL	STOCK STATUS
		PH	VOLTS	HZ	SUBTROL HEAT SENSOR	S.F.	# LEADS	WIRE SIZE (AWG)		
<b>20 hp 15 kW</b>	WATER WELL	3P	200-208	60	Not Available	1.15	3	#8 w/GND	236 654 90	YES
		3P	220	50	Not Available	1.00	3	#8 w/GND	236 684 90	
		3P	220	60	Not Available	1.15	6-90°	#10 w/GND	236 674 90	
		3P	230	60	Not Available	1.15	3	#8 w/GND	236 604 90	YES
		3P	230	60	Not Available	1.15	6-90°	#10 w/GND	236 724 90	
		3P	380	60	Not Available	1.15	3	#10 w/GND	236 664 90	YES
		3P	380	60	Not Available	1.15	6-90°	#10 w/GND	236 784 90	
		3P	415	50	Not Available	1.00	3	#10 w/GND	236 694 90	
		3P	460/380-415	60/50	Not Available	1.15/1.00	3	#10 w/GND	236 614 90	YES
		3P	460/380-415	60/50	Not Available	1.15/1.00	6-90°	#10 w/GND	236 714 90	YES
		3P	575	60	Not Available	1.15	3	#10 w/GND	236 624 90	
	SAND FIGHTER	3P	200-208	60	YES	1.15	3	#8 w/GND	236 654 81	YES
		3P	220	50	YES	1.00	3	#8 w/GND	236 684 81	
		3P	220	50	YES	1.00	6-90°	#10 w/GND	236 674 81	
		3P	230	60	YES	1.15	3	#8 w/GND	236 604 81	YES
		3P	230	60	YES	1.15	6-90°	#10 w/GND	236 724 81	YES
		3P	380	60	YES	1.15	3	#10 w/GND	236 664 81	
		3P	380	60	YES	1.15	6-90°	#10 w/GND	236 784 81	
		3P	415	50	YES	1.00	3	#10 w/GND	236 694 81	
		3P	460/380-415	60/50	YES	1.15/1.00	3	#10 w/GND	236 614 81	YES
		3P	460/380-415	60/50	YES	1.15/1.00	6-90°	#10 w/GND	236 714 81	
		3P	575	60	YES	1.15	3	#10 w/GND	236 624 81	YES
	316 SS	3P	200-208	60	YES	1.15	3	#8 w/GND	236 654 40	
		3P	220	50	YES	1.00	3	#8 w/GND	236 684 40	
		3P	220	50	YES	1.00	6-90°	#10 w/GND	236 674 40	
		3P	230	60	YES	1.15	3	#8 w/GND	236 604 40	YES
		3P	230	60	YES	1.15	6-90°	#10 w/GND	236 724 40	
		3P	380	60	YES	1.15	3	#10 w/GND	236 664 40	
		3P	380	60	YES	1.15	6-90°	#10 w/GND	236 784 40	
		3P	415	50	YES	1.00	3	#10 w/GND	236 694 40	
3P		460/380-415	60/50	YES	1.15/1.00	3	#10 w/GND	236 614 40	YES	
3P		460/380-415	60/50	YES	1.15/1.00	6-90°	#10 w/GND	236 714 40		
3P		575	60	YES	1.15	3	#10 w/GND	236 624 40		

# 6" Submersible Motors Standard

## 6-Inch Models

HP (KW)	CONSTRUCTION	DESCRIPTION							MODEL	STOCK STATUS
		PH	VOLTS	HZ	SUBTROL HEAT SENSOR	S.F.	# LEADS	WIRE SIZE (AWG)		
25 hp 18.5 kW	WATER WELL	3P	200-208	60	Not Available	1.15	3	#8 w/GND	236 655 90	YES
		3P	220	50	Not Available	1.00	3	#8 w/GND	236 685 90	
		3P	220	50	Not Available	1.00	6-90°	#10 w/GND	236 675 90	
		3P	230	60	Not Available	1.15	3	#8 w/GND	236 605 90	YES
		3P	230	60	Not Available	1.15	6-90°	#10 w/GND	236 725 90	
		3P	380	60	Not Available	1.15	3	#10 w/GND	236 665 90	YES
		3P	380	60	Not Available	1.15	6-90°	#10 w/GND	236 785 90	
		3P	415	50	Not Available	1.00	3	#10 w/GND	236 695 90	
		3P	460/380-415	60/50	Not Available	1.15/1.00	3	#10 w/GND	236 615 90	YES
		3P	460/380-415	60/50	Not Available	1.15/1.00	6-90°	#10 w/GND	236 715 90	YES
		3P	575	60	Not Available	1.15	3	#10 w/GND	236 625 90	
	SAND FIGHTER	3P	200-208	60	YES	1.15	3	#8 w/GND	236 655 81	YES
		3P	220	50	YES	1.00	3	#8 w/GND	236 685 81	
		3P	220	50	YES	1.00	6-90°	#10 w/GND	236 675 81	
		3P	230	60	YES	1.15	3	#8 w/GND	236 605 81	YES
		3P	230	60	YES	1.15	6-90°	#10 w/GND	236 725 81	YES
		3P	380	60	YES	1.15	3	#10 w/GND	236 665 81	
		3P	380	60	YES	1.15	6-90°	#10 w/GND	236 785 81	
		3P	415	50	YES	1.00	3	#10 w/GND	236 695 81	
		3P	460/380-415	60/50	YES	1.15/1.00	3	#10 w/GND	236 615 81	YES
		3P	460/380-415	60/50	YES	1.15/1.00	6-90°	#10 w/GND	236 715 81	
		3P	575	60	YES	1.15	3	#10 w/GND	236 625 81	YES
	316 SS	3P	200-208	60	YES	1.15	3	#8 w/GND	236 655 40	
		3P	220	50	YES	1.00	3	#8 w/GND	236 685 40	
		3P	220	50	YES	1.00	6-90°	#10 w/GND	236 675 40	
		3P	230	60	YES	1.15	3	#8 w/GND	236 605 40	
		3P	230	60	YES	1.15	6-90°	#10 w/GND	236 725 40	
		3P	380	60	YES	1.15	3	#10 w/GND	236 665 40	
		3P	380	60	YES	1.15	6-90°	#10 w/GND	236 785 40	
		3P	415	50	YES	1.00	3	#10 w/GND	236 695 40	
		3P	460/380-415	60/50	YES	1.15/1.00	3	#10 w/GND	236 615 40	YES
		3P	460/380-415	60/50	YES	1.15/1.00	6-90°	#10 w/GND	236 715 40	
		3P	575	60	YES	1.15	3	#10 w/GND	236 625 40	

# 6" Submersible Motors Standard

## 6-Inch Models

HP (KW)	CONSTRUCTION	DESCRIPTION							MODEL	STOCK STATUS
		PH	VOLTS	HZ	SUBTROL HEAT SENSOR	S.F.	# LEADS	WIRE SIZE (AWG)		
30 hp 22 kW	WATER WELL	3P	200-208	60	Not Available	1.15	3	#8 w/GND	236 656 90	YES
		3P	220	50	Not Available	1.00	3	#8 w/GND	236 686 90	
		3P	220	50	Not Available	1.00	6-90°	#10 w/GND	236 676 90	
		3P	230	60	Not Available	1.15	3	#8 w/GND	236 606 90	YES
		3P	230	60	Not Available	1.15	6-90°	#10 w/GND	236 726 90	
		3P	380	60	Not Available	1.15	3	#10 w/GND	236 666 90	YES
		3P	380	60	Not Available	1.15	6-90°	#10 w/GND	236 786 90	
		3P	415	50	Not Available	1.00	3	#10 w/GND	236 696 90	
		3P	460/380-415	60/50	Not Available	1.15/1.00	3	#10 w/GND	236 616 90	YES
		3P	460/380-415	60/50	Not Available	1.15/1.00	6-90°	#10 w/GND	236 716 90	YES
	3P	575	60	Not Available	1.15	3	#10 w/GND	236 626 90		
	SAND FIGHTER	3P	200-208	60	YES	1.15	3	#8 w/GND	236 656 81	YES
		3P	220	50	YES	1.00	3	#8 w/GND	236 686 81	
		3P	220	50	YES	1.00	6-90°	#10 w/GND	236 676 81	
		3P	230	60	YES	1.15	3	#8 w/GND	236 606 81	YES
		3P	230	60	YES	1.15	6-90°	#10 w/GND	236 726 81	YES
		3P	380	60	YES	1.15	3	#10 w/GND	236 666 81	
		3P	380	60	YES	1.15	6-90°	#10 w/GND	236 786 81	
		3P	415	50	YES	1.00	3	#10 w/GND	236 696 81	
		3P	460/380-415	60/50	YES	1.15/1.00	3	#10 w/GND	236 616 81	YES
		3P	460/380-415	60/50	YES	1.15/1.00	6-90°	#10 w/GND	236 716 81	
	3P	575	60	YES	1.15	3	#10 w/GND	236 626 81	YES	
	316 SS	3P	200-208	60	YES	1.15	3	#8 w/GND	236 656 40	
		3P	220	50	YES	1.00	3	#8 w/GND	236 686 40	
		3P	220	50	YES	1.00	6-90°	#10 w/GND	236 676 40	
		3P	230	60	YES	1.15	3	#8 w/GND	236 606 40	
		3P	230	60	YES	1.15	6-90°	#10 w/GND	236 726 40	
		3P	380	60	YES	1.15	3	#10 w/GND	236 666 40	
		3P	380	60	YES	1.15	6-90°	#10 w/GND	236 786 40	
		3P	415	50	YES	1.00	3	#10 w/GND	236 696 40	
		3P	460/380-415	60/50	YES	1.15/1.00	3	#10 w/GND	236 616 40	YES
		3P	460/380-415	60/50	YES	1.15/1.00	6-90°	#10 w/GND	236 716 40	
	3P	575	60	YES	1.15	3	#10 w/GND	236 626 40		

# 6" Submersible Motors Standard

## 6-Inch Models

HP (KW)	CONSTRUCTION	DESCRIPTION							MODEL	STOCK STATUS
		PH	VOLTS	HZ	SUBTROL HEAT SENSOR	S.F.	# LEADS	WIRE SIZE (AWG)		
<b>40 hp 30 kW</b>	WATER WELL	3P	380	60	Not Available	1.15	3	#8 w/GND	236 667 90	
		3P	380	60	Not Available	1.15	6-90°	#10 w/GND	236 787 90	
		3P	415	50	Not Available	1.00	3	#8 w/GND	236 697 90	
		3P	460/380-415	60/50	Not Available	1.15/1.00	3	#8 w/GND	236 617 90	YES
		3P	460/380-415	60/50	Not Available	1.15/1.00	6-90°	#10 w/GND	236 717 90	
		3P	575	60	Not Available	1.15	3	#8 w/GND	236 627 90	
	SAND FIGHTER	3P	380	60	YES	1.15	3	#8 w/GND	236 667 81	YES
		3P	380	60	YES	1.15	6-90°	#10 w/GND	236 787 81	
		3P	415	50	YES	1.00	3	#8 w/GND	236 697 81	
		3P	460/380-415	60/50	YES	1.15/1.00	3	#8 w/GND	236 617 81	YES
		3P	460/380-415	60/50	YES	1.15/1.00	6-90°	#10 w/GND	236 717 81	YES
		3P	575	60	YES	1.15	3	#8 w/GND	236 627 81	YES
	316 SS	3P	380	60	YES	1.15	3	#8 w/GND	236 667 40	
		3P	380	60	YES	1.15	6-90°	#10 w/GND	236 787 40	
		3P	415	50	YES	1.00	3	#8 w/GND	236 697 40	
		3P	460/380-415	60/50	YES	1.15/1.00	3	#8 w/GND	236 617 40	YES
		3P	460/380-415	60/50	YES	1.15/1.00	6-90°	#10 w/GND	236 717 40	
		3P	575	60	YES	1.15	3	#8 w/GND	236 627 40	
<b>50 hp 30 kW</b>	WATER WELL WITH SAND FIGHTER SEAL	3P	380	60	YES	1.15	3	#8 w/GND	276 668 60	YES
		3P	380	60	YES	1.15	6-90°	#8 w/GND	276 788 60	
		3P	415	50	YES	1.00	3	#8 w/GND	276 698 60	
		3P	460/380-415	60/50	YES	1.15/1.00	3	#8 w/GND	276 618 60	YES
		3P	460/380-415	60/50	YES	1.15/1.00	6-90°	#8 w/GND	276 718 60	YES
		3P	575	60	YES	1.15	3	#8 w/GND	276 628 60	YES
	316 SS	3P	380	60	YES	1.15	3	#8 w/GND	276 668 40	
		3P	380	60	YES	1.15	6-90°	#8 w/GND	276 788 40	
		3P	415	50	YES	1.00	3	#8 w/GND	276 698 40	
		3P	460/380-415	60/50	YES	1.15/1.00	3	#8 w/GND	276 618 40	YES
		3P	460/380-415	60/50	YES	1.15/1.00	6-90°	#8 w/GND	276 718 40	
		3P	575	60	YES	1.15	3	#8 w/GND	276 628 40	
<b>60 hp 45 kW</b>	WATER WELL WITH SAND FIGHTER SEAL	3P	380	60	YES	1.15	3	#8 w/GND	276 669 60	YES
		3P	380	60	YES	1.15	6-90°	#8 w/GND	276 789 60	
		3P	415	50	YES	1.00	3	#8 w/GND	276 699 60	
		3P	460/380-415	60/50	YES	1.15/1.00	3	#8 w/GND	276 619 60	YES
		3P	460/380-415	60/50	YES	1.15/1.00	6-90°	#8 w/GND	276 719 60	YES
		3P	575	60	YES	1.15	3	#8 w/GND	276 629 60	YES
	316 SS	3P	380	60	YES	1.15	3	#8 w/GND	276 669 40	
		3P	380	60	YES	1.15	6-90°	#8 w/GND	276 789 40	
		3P	415	50	YES	1.00	3	#8 w/GND	276 699 40	
		3P	460/380-415	60/50	YES	1.15/1.00	3	#8 w/GND	276 619 40	YES
		3P	460/380-415	60/50	YES	1.15/1.00	6-90°	#8 w/GND	276 719 40	
		3P	575	60	YES	1.15	3	#8 w/GND	276 629 40	

**NOTES:**

1. Models designated above as Sand Fighter™ are water well construction.
2. All 316 SS and Ni-Resist models are equipped with Sand Fighter sealing system.
3. All models listed above include factory-installed leads (13 ft).

## 6" Submersible Motors Hi-Temp 90



### Applications

These motors are built for dependable operation in 6" diameter or larger water wells, in applications with higher temperature, high thrust or low flow.

### Basic Features

- Able to operate in water ambients up to 194 °F (90 °C)
- In 86 °F (30 °C) ambient or less they supply 25% more downthrust and 100% more upthrust than standard product
- No flow capable when submerged in lakes or wells 12" diameter or larger and water 86 °F or less
- Double flanged NEMA mounting design
- Stainless steel splined shaft
- StatorShield™ Franklin's six feature encapsulation system
- High Capacity Kingsbury type water lubricated thrust bearing
- Factory filled with Franklin's non-toxic water soluble fill solution
- Field replaceable lead using Franklin's exclusive Water Bloc™ Technology
- Full 3450 rpm 60 Hz design point
- External sand slinger on shaft
- Sand Fighter™ mechanical face seal system at shaft exit
- Copper bar rotor
- All models variable frequency drive (VFD) approved

### Special Options

- SubMonitor™ is a state-of-the-art electronic motor overload that is sold separately.
  - Mounts in the above ground panel requiring no additional wiring to the motor.
  - User friendly, field proven.
  - Protection monitors for balanced power, overload, underload, overheating, rapid cycling and more.
  - Can be used with or without a SubTrol™ heat sensor.
  - Supplies superior heat protection when manufactured with the SubTrol heat sensor.

Consult factory for other voltage, hertz and horsepower ratings not listed in this catalog.

Specifications are subject to change without notice. Contact Franklin Electric if current materials are required for bid specifications.

# 6" Submersible Motors Hi-Temp 90

## 6-Inch Three-Phase Hi-Temp 90 Motor Specifications

Hz	Phase	Hp Range	kW Range	Poles	RPM	Max. Ambient Temp.	Duty Rating
60	3	5 - 40	3.7 - 30	2	3450	195 °F / 90 °C	Continuous at 0.5 ft/sec flow past motor*
50	3	5 - 40	3.7 - 30	2	2875	195 °F / 90 °C	Continuous at 0.5 ft/sec flow past motor*

\* Motors are also rated for continuous duty up to 86 °F (30 °C) water temperature with NO FLOW in lakes or in wells 12 inches or larger in diameter.

## 6-Inch Hi-Temp 90 Construction Materials

Component	Construction Type	
	Hi-Temp 90C (300 SS Series Shell)	Hi-Temp 90C (316 SS Construction)
UL Insulation Class Rating	Class F	Class F
Motor Ambient Temperature Rating	194 °F / 90 °C (5-40 hp)	194 °F / 90 °C (5-40 hp)
Stator Resin Type	FE Hi-Temp	FE Hi-Temp
Motor Fill Solution (Water Soluble/Non-Toxic)	FES92	FES92
Top End Bell & Thrust Housing	Epoxy Coated Gray Iron	316 SS
On Winding SubTrol™ heat sensor	Not Available	Not Available
Stator Shell	300 SS Series	316 SS
Stator Ends	Carbon Steel	316 SS
Shaft Extension	300 SS Series (5-20 hp), 17-4 SS (25-40 hp)	17-4 SS
Bushing	Bronze	316 SS
Bushing Retainer	300 SS Series	316 SS
Seal Mechanical Seal	Sand Fighter™ Mechanical Seal System	Sand Fighter Mechanical Seal System
Mechanical Seal Rubber Compnents	Viton®	Viton®
Diaphragm Material	Viton®	Viton®
Diaphragm Plate	300 SS Series	316 SS
Diaphragm Spring	300 SS Series	25-6 MO SS
Shaft Slinger	Viton®	Viton®
Lead Wire	XLPO	XLPO
Lead Potting	Epoxy	Epoxy
Lead Jam Nut	Brass	316 SS
Thrust Bearing Rating (86 °F / 30 °C)	Standard 5-20 hp • 4,500 lbs Standard 25-40 hp • 7,500 lbs	Standard 5-20 hp • 4,500 lbs Standard 25-40 hp • 7,500 lbs
Method Of Conneting System Ground To Motor	Ground Wire In Power Lead Connector	Ground Wire In Power Lead Connector

Specifications subject to change without notice. Contact Franklin Electric if current material types are required for bid specifications.

Viton® is a registered trademark of DuPont Dow Elastomers.

# 6" Submersible Motors Hi-Temp 90

## 6-Inch Hi-Temp Dimensions and Weights

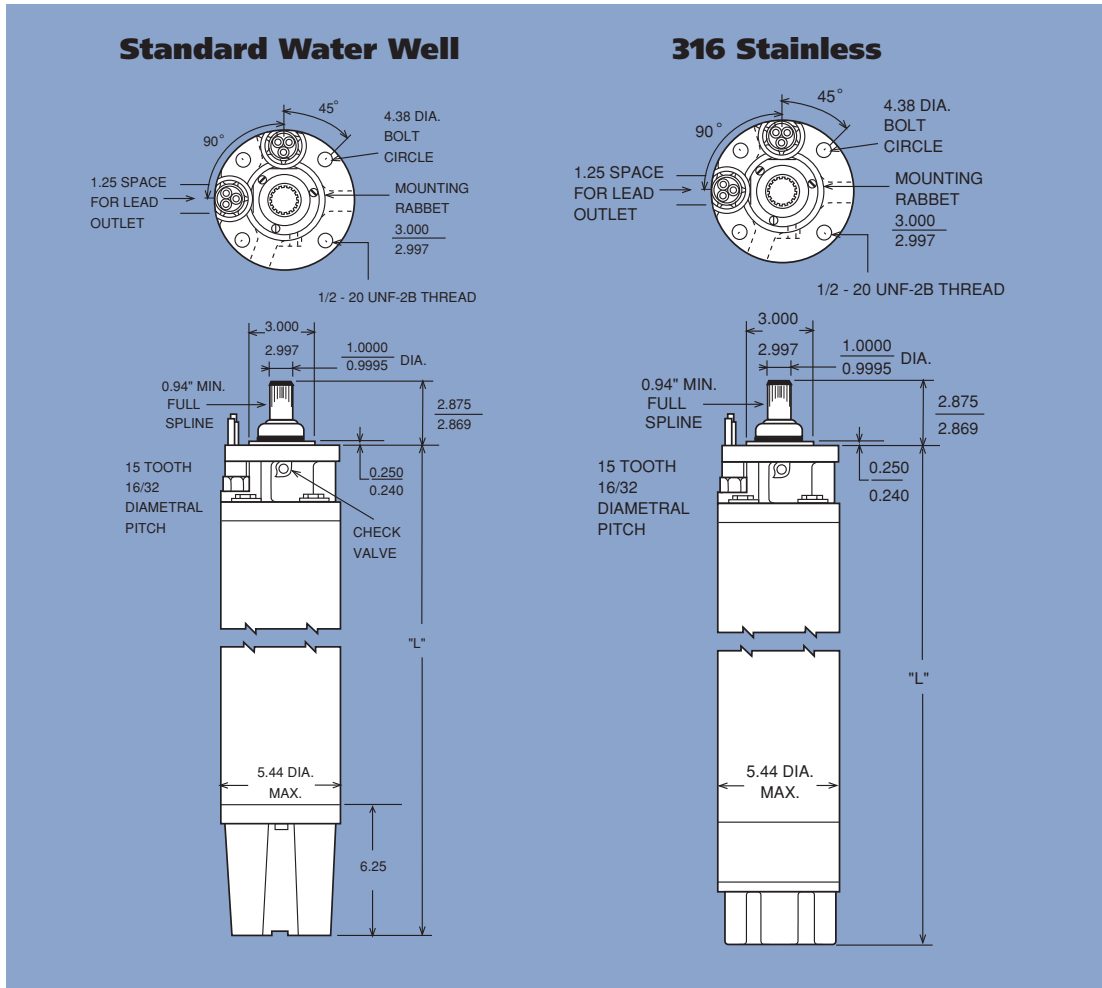

### 304 SS Shell 3-Lead

HP	KW	"L" (inches)	SHIPPING WEIGHT		MOTOR CARTON SIZE (in inches)
			LBS	KG	
5	3.7	26.40	116	53	8.75 x 11.25 x 34.50
7.5	5.5	28.96	129	59	8.75 x 11.25 x 37.00
10	7.5	31.52	145	66	8.75 x 11.25 x 42.25
15	11	34.09	156	71	8.75 x 11.25 x 42.25
20	15	36.65	174	79	8.75 x 11.25 x 51.25
25	18.5	41.77	202	92	8.75 x 11.25 x 51.25
30	22	56.27	300	136	8.75 x 10.50 x 71.75
40	30	62.27	330	150	8.75 x 10.50 x 71.75

### 316 SS Shell 3-Lead

HP	KW	"L" (inches)	SHIPPING WEIGHT		MOTOR CARTON SIZE (in inches)
			LBS	KG	
5	3.7	26.40	116	53	8.75 x 11.25 x 34.50
7.5	5.5	28.96	129	59	8.75 x 11.25 x 37.00
10	7.5	31.52	145	66	8.75 x 11.25 x 42.25
15	11	34.09	156	71	8.75 x 11.25 x 42.25
20	15	36.65	174	79	8.75 x 11.25 x 51.25
25	18.5	41.77	202	92	8.75 x 11.25 x 51.25
30	22	56.27	300	136	8.75 x 10.50 x 71.75
40	30	62.27	330	150	8.75 x 10.50 x 71.75

6-Lead Y-Δ models available. (Add 5 lbs to shipping weight.)

# 6" Submersible Motors Hi-Temp 90

## Hi-Temp 90 6-Inch Models

HP (KW)	CONSTRUCTION	DESCRIPTION						MODEL	STOCK STATUS
		PH	VOLTS	HZ	S.F.	# LEADS	WIRE SIZE (AWG)		
5 hp 3.7 kW	WATER WELL WITH SAND FIGHTER SEAL	3P	200	60	1.15	3	#8 w/GND	276 650 00	
		3P	220	50	1.00	3	#8 w/GND	276 680 00	
		3P	220	50	1.00	6-90°	#8 w/GND	276 670 00	
		3P	230	60	1.15	3	#8 w/GND	276 600 00	
		3P	230	60	1.15	6-90°	#8 w/GND	276 720 00	
		3P	380	60	1.15	3	#8 w/GND	276 660 00	
		3P	380	60	1.15	6-90°	#8 w/GND	276 780 00	
		3P	415	50	1.00	3	#8 w/GND	276 690 00	
		3P	460/380-415	60/50	1.15/1.00	3	#8 w/GND	276 610 00	
		3P	460/380-415	60/50	1.15/1.00	6-90°	#8 w/GND	276 710 00	
	3P	575	60	1.15	3	#8 w/GND	276 620 00		
	316 SS	3P	200	60	1.15	3	#8 w/GND	276 650 30	
		3P	220	50	1.00	3	#8 w/GND	276 680 30	
		3P	220	50	1.00	6-90°	#8 w/GND	276 670 30	
		3P	230	60	1.15	3	#8 w/GND	276 600 30	
		3P	230	60	1.15	6-90°	#8 w/GND	276 720 30	
		3P	380	60	1.15	3	#8 w/GND	276 660 30	
		3P	380	60	1.15	6-90°	#8 w/GND	276 780 30	
		3P	415	50	1.00	3	#8 w/GND	276 690 30	
		3P	460/380-415	60/50	1.15/1.00	3	#8 w/GND	276 610 30	
3P		460/380-415	60/50	1.15/1.00	6-90°	#8 w/GND	276 710 30		
3P	575	60	1.15	3	#8 w/GND	276 620 30			
7.5 hp 5.5 kW	WATER WELL WITH SAND FIGHTER SEAL	3P	200	60	1.15	3	#8 w/GND	276 651 00	
		3P	220	50	1.00	3	#8 w/GND	276 681 00	
		3P	220	50	1.00	6-90°	#8 w/GND	276 671 00	
		3P	230	60	1.15	3	#8 w/GND	276 601 00	
		3P	230	60	1.15	6-90°	#8 w/GND	276 721 00	
		3P	380	60	1.15	3	#8 w/GND	276 661 00	
		3P	380	60	1.15	6-90°	#8 w/GND	276 781 00	
		3P	415	50	1.00	3	#8 w/GND	276 691 00	
		3P	460/380-415	60/50	1.15/1.00	3	#8 w/GND	276 611 00	
		3P	460/380-415	60/50	1.15/1.00	6-90°	#8 w/GND	276 711 00	
	3P	575	60	1.15	3	#8 w/GND	276 621 00		
	316 SS	3P	200	60	1.15	3	#8 w/GND	276 651 30	
		3P	220	50	1.00	3	#8 w/GND	276 681 30	
		3P	220	50	1.00	6-90°	#8 w/GND	276 671 30	
		3P	230	60	1.15	3	#8 w/GND	276 601 30	
		3P	230	60	1.15	6-90°	#8 w/GND	276 721 30	
		3P	380	60	1.15	3	#8 w/GND	276 661 30	
		3P	380	60	1.15	6-90°	#8 w/GND	276 781 30	
		3P	415	50	1.00	3	#8 w/GND	276 691 30	
		3P	460/380-415	60/50	1.15/1.00	3	#8 w/GND	276 611 30	
3P		460/380-415	60/50	1.15/1.00	6-90°	#8 w/GND	276 711 30		
3P	575	60	1.15	3	#8 w/GND	276 621 30			

# 6" Submersible Motors Hi-Temp 90

## Hi-Temp 90 6-Inch Models

HP (KW)	CONSTRUCTION	DESCRIPTION						MODEL	STOCK STATUS
		PH	VOLTS	HZ	S.F.	# LEADS	WIRE SIZE (AWG)		
10 hp 7.5 kW	WATER WELL WITH SAND FIGHTER SEAL	3P	200	60	1.15	3	#8 w/GND	276 652 00	
		3P	220	50	1.00	3	#8 w/GND	276 682 00	
		3P	220	50	1.00	6-90°	#8 w/GND	276 672 00	
		3P	230	60	1.15	3	#8 w/GND	276 602 00	
		3P	230	60	1.15	6-90°	#8 w/GND	276 722 00	
		3P	380	60	1.15	3	#8 w/GND	276 662 00	
		3P	380	60	1.15	6-90°	#8 w/GND	276 782 00	
		3P	415	50	1.00	3	#8 w/GND	276 692 00	
		3P	460/380-415	60/50	1.15/1.00	3	#8 w/GND	276 612 00	YES
		3P	460/380-415	60/50	1.15/1.00	6-90°	#8 w/GND	276 712 00	
	3P	575	60	1.15	3	#8 w/GND	276 622 00		
	316 SS	3P	200	60	1.15	3	#8 w/GND	276 652 30	
		3P	220	50	1.00	3	#8 w/GND	276 682 30	
		3P	220	50	1.00	6-90°	#8 w/GND	276 672 30	
		3P	230	60	1.15	3	#8 w/GND	276 602 30	
		3P	230	60	1.15	6-90°	#8 w/GND	276 722 30	
		3P	380	60	1.15	3	#8 w/GND	276 662 30	
		3P	380	60	1.15	6-90°	#8 w/GND	276 782 30	
		3P	415	50	1.00	3	#8 w/GND	276 692 30	
		3P	460/380-415	60/50	1.15/1.00	3	#8 w/GND	276 612 30	
3P		460/380-415	60/50	1.15/1.00	6-90°	#8 w/GND	276 712 30		
3P	575	60	1.15	3	#8 w/GND	276 622 30			
15 hp 11 kW	WATER WELL WITH SAND FIGHTER SEAL	3P	200	60	1.15	3	#8 w/GND	276 653 00	
		3P	220	50	1.00	3	#8 w/GND	276 683 00	
		3P	220	50	1.00	6-90°	#8 w/GND	276 673 00	
		3P	230	60	1.15	3	#8 w/GND	276 603 00	
		3P	230	60	1.15	6-90°	#8 w/GND	276 723 00	
		3P	380	60	1.15	3	#8 w/GND	276 663 00	
		3P	380	60	1.15	6-90°	#8 w/GND	276 783 00	
		3P	415	50	1.00	3	#8 w/GND	276 693 00	
		3P	460/380-415	60/50	1.15/1.00	3	#8 w/GND	276 613 00	YES
		3P	460/380-415	60/50	1.15/1.00	6-90°	#8 w/GND	276 713 00	
	3P	575	60	1.15	3	#8 w/GND	276 623 00		
	316 SS	3P	200	60	1.15	3	#8 w/GND	276 653 30	
		3P	220	50	1.00	3	#8 w/GND	276 683 30	
		3P	220	50	1.00	6-90°	#8 w/GND	276 673 30	
		3P	230	60	1.15	3	#8 w/GND	276 603 30	
		3P	230	60	1.15	6-90°	#8 w/GND	276 723 30	
		3P	380	60	1.15	3	#8 w/GND	276 663 30	
		3P	380	60	1.15	6-90°	#8 w/GND	276 783 30	
		3P	415	50	1.00	3	#8 w/GND	276 693 30	
		3P	460/380-415	60/50	1.15/1.00	3	#8 w/GND	276 613 30	
3P		460/380-415	60/50	1.15/1.00	6-90°	#8 w/GND	276 713 30		
3P	575	60	1.15	3	#8 w/GND	276 623 30			

# 6" Submersible Motors Hi-Temp 90

## Hi-Temp 90 6-Inch Models

HP (KW)	CONSTRUCTION	DESCRIPTION						MODEL	STOCK STATUS
		PH	VOLTS	HZ	S.F.	# LEADS	WIRE SIZE (AWG)		
20 hp 15 kW	WATER WELL WITH SAND FIGHTER SEAL	3P	200	60	1.15	3	#8 w/GND	276 654 00	
		3P	220	50	1.00	3	#8 w/GND	276 684 00	
		3P	220	50	1.00	6-90°	#8 w/GND	276 674 00	
		3P	230	60	1.15	3	#8 w/GND	276 604 00	
		3P	230	60	1.15	6-90°	#8 w/GND	276 724 00	
		3P	380	60	1.15	3	#8 w/GND	276 664 00	
		3P	380	60	1.15	6-90°	#8 w/GND	276 784 00	
		3P	415	50	1.00	3	#8 w/GND	276 694 00	
		3P	460/380-415	60/50	1.15/1.00	3	#8 w/GND	276 614 00	YES
		3P	460/380-415	60/50	1.15/1.00	6-90°	#8 w/GND	276 714 00	
	3P	575	60	1.15	3	#8 w/GND	276 624 00		
	316 SS	3P	200	60	1.15	3	#8 w/GND	276 654 30	
		3P	220	50	1.00	3	#8 w/GND	276 684 30	
		3P	220	50	1.00	6-90°	#8 w/GND	276 674 30	
		3P	230	60	1.15	3	#8 w/GND	276 604 30	
		3P	230	60	1.15	6-90°	#8 w/GND	276 724 30	
		3P	380	60	1.15	3	#8 w/GND	276 664 30	
		3P	380	60	1.15	6-90°	#8 w/GND	276 784 30	
		3P	415	50	1.00	3	#8 w/GND	276 694 30	
		3P	460/380-415	60/50	1.15/1.00	3	#8 w/GND	276 614 30	
3P		460/380-415	60/50	1.15/1.00	6-90°	#8 w/GND	276 714 30		
3P	575	60	1.15	3	#8 w/GND	276 624 30			
25 hp 18.5 kW	WATER WELL WITH SAND FIGHTER SEAL	3P	200	60	1.15	3	#8 w/GND	276 655 01	
		3P	220	50	1.00	3	#8 w/GND	276 685 01	
		3P	220	50	1.00	6-90°	#8 w/GND	276 675 01	
		3P	230	60	1.15	3	#8 w/GND	276 605 01	
		3P	230	60	1.15	6-90°	#8 w/GND	276 725 01	
		3P	380	60	1.15	3	#8 w/GND	276 665 01	
		3P	380	60	1.15	6-90°	#8 w/GND	276 785 01	
		3P	415	50	1.00	3	#8 w/GND	276 695 01	
		3P	460/380-415	60/50	1.15/1.00	3	#8 w/GND	276 615 01	YES
		3P	460/380-415	60/50	1.15/1.00	6-90°	#8 w/GND	276 715 01	
	3P	575	60	1.15	3	#8 w/GND	276 625 01		
	316 SS	3P	200	60	1.15	3	#8 w/GND	276 655 31	
		3P	220	50	1.00	3	#8 w/GND	276 685 31	
		3P	220	50	1.00	6-90°	#8 w/GND	276 675 31	
		3P	230	60	1.15	3	#8 w/GND	276 605 31	
		3P	230	60	1.15	6-90°	#8 w/GND	276 725 31	
		3P	380	60	1.15	3	#8 w/GND	276 665 31	
		3P	380	60	1.15	6-90°	#8 w/GND	276 785 31	
		3P	415	50	1.00	3	#8 w/GND	276 695 31	
		3P	460/380-415	60/50	1.15/1.00	3	#8 w/GND	276 615 31	
3P		460/380-415	60/50	1.15/1.00	6-90°	#8 w/GND	276 715 31		
3P	575	60	1.15	3	#8 w/GND	276 625 31			

# 6" Submersible Motors Hi-Temp 90

## Hi-Temp 90 6-Inch Models

HP (KW)	CONSTRUCTION	DESCRIPTION						MODEL	STOCK STATUS
		PH	VOLTS	HZ	S.F.	# LEADS	WIRE SIZE (AWG)		
<b>30 hp 22 kW</b>	WATER WELL WITH SAND FIGHTER SEAL	3P	200	60	1.15	3	#8 w/GND	276 656 01	
		3P	220	50	1.00	3	#8 w/GND	276 686 01	
		3P	220	50	1.00	6-90°	#8 w/GND	276 676 01	
		3P	230	60	1.15	3	#8 w/GND	276 606 01	
		3P	230	60	1.15	6-90°	#8 w/GND	276 726 01	
		3P	380	60	1.15	3	#8 w/GND	276 666 01	
		3P	380	60	1.15	6-90°	#8 w/GND	276 786 01	
		3P	415	50	1.00	3	#8 w/GND	276 696 01	
		3P	460/380-415	60/50	1.15/1.00	3	#8 w/GND	276 616 01	YES
		3P	460/380-415	60/50	1.15/1.00	6-90°	#8 w/GND	276 716 01	
	3P	575	60	1.15	3	#8 w/GND	276 626 01		
	316 SS	3P	200	60	1.15	3	#8 w/GND	276 656 31	
		3P	220	50	1.00	3	#8 w/GND	276 686 31	
		3P	220	50	1.00	6-90°	#8 w/GND	276 676 31	
		3P	230	60	1.15	3	#8 w/GND	276 606 31	
		3P	230	60	1.15	6-90°	#8 w/GND	276 726 31	
		3P	380	60	1.15	3	#8 w/GND	276 666 31	
		3P	380	60	1.15	6-90°	#8 w/GND	276 786 31	
		3P	415	50	1.00	3	#8 w/GND	276 696 31	
		3P	460/380-415	60/50	1.15/1.00	3	#8 w/GND	276 616 31	
3P		460/380-415	60/50	1.15/1.00	6-90°	#8 w/GND	276 716 31		
3P	575	60	1.15	3	#8 w/GND	276 626 31			
<b>40 hp 30 kW</b>	WATER WELL WITH SAND FIGHTER SEAL	3P	380	60	1.15	3	#8 w/GND	276 667 01	
		3P	380	60	1.15	6-90°	#8 w/GND	276 787 01	
		3P	415	50	1.00	3	#8 w/GND	276 697 01	
		3P	460/380-415	60/50	1.15/1.00	3	#8 w/GND	276 617 01	YES
		3P	460/380-415	60/50	1.15/1.00	6-90°	#8 w/GND	276 717 01	
		3P	575	60	1.15	3	#8 w/GND	276 627 01	
	316 SS	3P	380	60	1.15	3	#8 w/GND	276 667 31	
		3P	380	60	1.15	6-90°	#8 w/GND	276 787 31	
		3P	415	50	1.00	3	#8 w/GND	276 697 31	
		3P	460/380-415	60/50	1.15/1.00	3	#8 w/GND	276 617 31	
3P	460/380-415	60/50	1.15/1.00	6-90°	#8 w/GND	276 717 31			
3P	575	60	1.15	3	#8 w/GND	276 627 31			

### NOTES:

1. All models listed above include leads (13 ft).
2. 6-Lead wye-delta models available in additional voltage ratings. Consult factory for availability.

# 6" Submersible Motors Leads

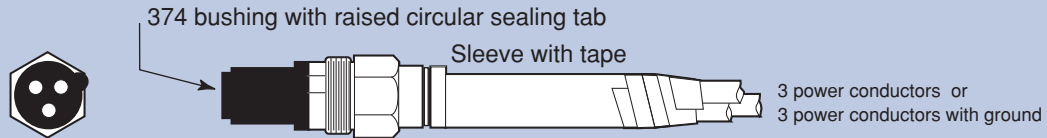

## 6" Lead Construction Material

Component	Material
Wire	XLPE 125 °C
Sleeve	Brass or 316 SS
Potting	Epoxy
Jam Nut	Brass or 316 SS

Specifications subject to change without notice. Contact Franklin Electric if current material types are required for bid specifications.

## Standard XLPE 125 °C Lead

Excellent resistance to ozone, abrasion, heat, and oxidizing chemicals.

# 6" Submersible Motors Leads

## Standard XLPE 125 °C Lead

FITS FE MOTOR RATING (460 V or 575 V 60 Hz)	JAM NUT MATERIAL	LEAD LENGTH		WIRE SIZE (AWG)	POWER WIRES	FE PART NUMBER	REPLACEMENT KIT NUMBER
		FT	M				
<b>All 6" Ratings</b>	Brass	13	4	#8	3 w/GND	152 671 901	305 517 901
	Brass	26	8	#8	3 w/GND	152 671 902	305 517 902
	316 SS	13	4	#8	3 w/GND	152 671 951	305 517 951
	316 SS	26	8	#8	3 w/GND	152 671 952	305 517 952
<b>5-30 hp 3.7-22 kW</b>	316 SS	50	15	#10	3 w/GND	152 672 955	305 518 955
	316 SS	75	23	#10	3 w/GND	152 672 957	305 518 957
	316 SS	100	30	#10	3 w/GND	152 672 960	305 518 960
	316 SS	125	38	#10	3 w/GND	152 672 962	305 518 962
	316 SS	150	45	#10	3 w/GND	152 672 965	305 518 965
<b>5-40 hp 3.7-30 kW</b>	316 SS	50	15	#8	3 w/GND	152 671 955	305 517 955
	316 SS	75	23	#8	3 w/GND	152 671 957	305 517 957
	316 SS	100	30	#8	3 w/GND	152 671 960	305 517 960
	316 SS	125	38	#8	3 w/GND	152 671 962	305 517 962
	316 SS	150	45	#8	3 w/GND	152 671 965	305 517 965

### NOTES:

1. Refer to Franklin Application Installation Maintenance (AIM) Manual for accurate cable sizing.
2. Nitrile cable uses lead sleeve 1" longer than standard.
3. MOTOR WARRANTY IS VOID if Franklin-supplied leads are not used.
4. Replacement leads are available in 25 ft. increments up to 150 ft. Special-cut lengths may be available at an additional charge. Consult factory for price and availability.

## XLPO 125 °C - Hi-Temp 90 Motors

FITS FE MOTOR RATING (460 V or 575 V 60 Hz)	JAM NUT MATERIAL	LEAD LENGTH		WIRE SIZE	POWER WIRES	FE PART NUMBER	REPLACEMENT KIT NUMBER
		FT	M				
<b>All 6" Ratings</b>	316 SS	13	4	#8	3 w/GND	152 683 951	305 519 951
	316 SS	26	8	#8	3 w/GND	152 683 952	305 519 952
	316 SS	50	15	#8	3 w/GND	152 683 955	305 519 955
<b>5-40 hp 3.7-30 kW</b>	316 SS	75	23	#8	3 w/GND	152 683 957	305 519 957
	316 SS	100	30	#8	3 w/GND	152 683 960	305 519 960
	316 SS	125	38	#8	3 w/GND	152 683 962	305 519 962
	316 SS	150	45	#8	3 w/GND	152 683 965	305 519 965

### NOTES:

1. Refer to Franklin Application Installation Maintenance (AIM) Manual for accurate cable sizing.
2. MOTOR WARRANTY IS VOID if Franklin-supplied leads are not used.

## 8" Submersible Motors Standard



### Applications

These motors are built for dependable operation in vertical 8" diameter or larger water wells.

### Basic Features

- Double Flanged NEMA mounting design
- Stainless steel splined shaft
- StatorShield™ Franklin's six feature encapsulation system
- High capacity Kingsbury type water lubricated thrust bearing
- Factory filled with Franklin's non-toxic water soluble fill solution
- Field replaceable lead using Franklin's exclusive Water Bloc™ technology
- Full 3525 rpm 60 Hz design point
- External sand slinger on shaft
- Mechanical face seal at shaft exit
- Copper bar rotor
- All models variable frequency drive (VFD) approved
- Franklin's Exclusive on winding SubTrol™ heat sensor for use with SubMonitor™

### Special Options

- Sand Fighter™ Models are equipped with:
  - Franklin's Exclusive Sand Fighter Sealing System for sand or other abrasives well water.
- 316 Stainless Steel construction models come standard with:
  - Franklin's Exclusive Sand Fighter Sealing System for sand or other abrasives well water.
  - Franklin's Exclusive on winding SubTrol™ heat sensor for use with SubMonitor.
- SubMonitor is a state-of-the-art electronic motor overload that is sold separately.
  - Mounts in the above ground panel requiring no additional wiring to the motor.
  - User friendly, field proven.
  - Protection monitors for balanced power, overload, underload, overheating, rapid cycling and more.
  - Can be used with or without a SubTrol heat sensor.
  - Supplies superior heat protection when manufactured with the SubTrol heat sensor.

Consult factory for other voltage, hertz and horsepower ratings not listed in this catalog. Specifications are subject to change without notice. Contact Franklin Electric if current materials are required for bid specifications.

# 8" Submersible Motors Standard

## 8-Inch Dimensions and Weights

**40 hp to 100 hp  
Type 2.1**

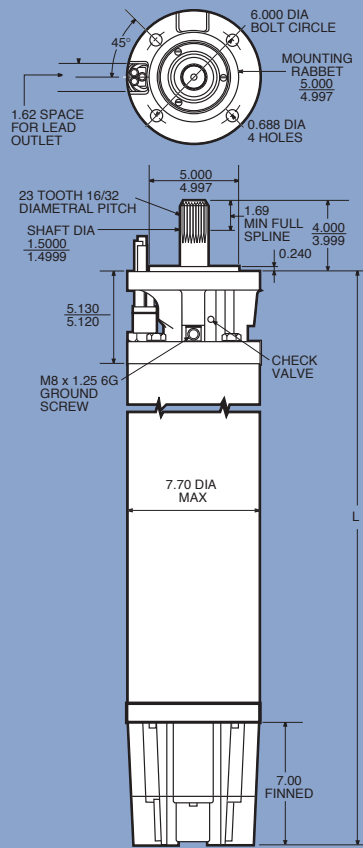

**125 hp to 200 hp  
Type 1.0**

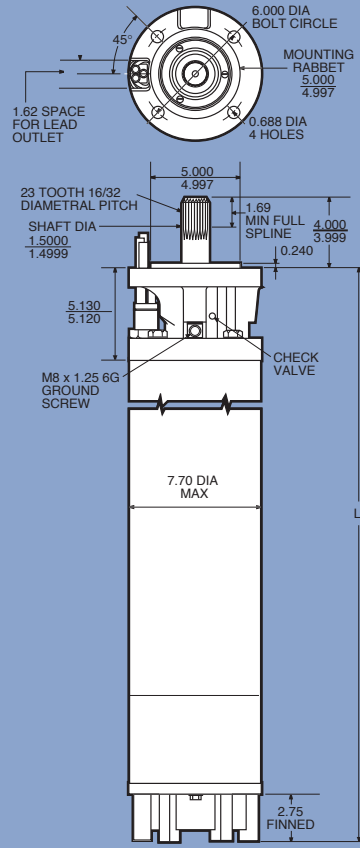

### 3-Lead Three-Phase Motors

HP	KW	"L" (inches)	SHIPPING WEIGHT		MOTOR CARTON SIZE (in inches)
			LBS	KG	
40	30	36.4	320	146	17 x 9.25 x 51
50	37	39.4	345	157	17 x 9.25 x 51
60	45	42.4	375	171	17 x 9.25 x 51
75	55	47.4	430	196	17 x 9.25 x 64
100	75	54.9	530	241	17 x 9.25 x 64
125	93	68.8	700	318	17 x 9.25 x 79
150	110	77.8	840	382	17 x 9.25 x 96
175	130	85.8	945	430	17 x 9.25 x 96
200	150	94.8	1040	473	17 x 9.25 x 108

6-Lead Y-Δ models available. (Add 5 lbs to shipping weight.)

# 8" Submersible Motors Standard

## Standard 8-Inch Three-Phase Motor Specifications

Hz	Phase	Hp Range	kW Range	Poles	RPM	Max. Ambient Temp.	Duty Rating
60	3	40 - 200	30 - 150	2	3525	86 °F / 30 °C	Continuous at 0.5 ft/sec flow past motor
50	3	40 - 200	30 - 150	2	2900	86 °F / 30 °C	Continuous at 0.5 ft/sec flow past motor

Higher temperature ambient motors are available in the 8" Hi-Temp motor line.

## Standard 8-Inch Construction Materials

Component	Construction Type		
	Standard Water Well (300 SS Series Shell)	Sand Fighter™ Water Well (300 SS Shell)	Corrosion Resistant (316 SS Construction)
Stator Resin Type	FE Standard	Per Standard Water Well	Per Standard Water Well
Motor Fill Solution (Water Soluble/Non-Toxic)	FES91	Per Standard Water Well	Per Standard Water Well
Top End Bell & Thrust Housing	Epoxy Coated Gray Iron	Per Standard Water Well	316 SS
SubTroI™ heat sensor (Mounted On Winding)	Yes	Per Standard Water Well	Per Standard Water Well
Stator Shell	300 SS Series	Per Standard Water Well	316 SS
Stator Ends	Carbon Steel	Per Standard Water Well	316 SS
Shaft Extension	17-4 SS	Per Standard Water Well	Per Standard Water Well
Bushing	Bronze	Per Standard Water Well	316 SS
Bushing Retainer	300 SS Series	Per Standard Water Well	316 SS
Shaft Mechanical Seal	Carbon Ceramic Seal (40-125 hp) Sand Fighter Seal System (150-200 hp)	Sand Fighter Seal System	Sand Fighter Seal System
Mechanical Seal Rubber Components	Nitrile	Per Standard Water Well	Per Standard Water Well
Diaphragm Material	Nitrile	Per Standard Water Well	Per Standard Water Well
Diaphragm Plate	300 SS	Per Standard Water Well	316 SS
Diaphragm Spring	300 SS	Per Standard Water Well	316 SS
Shaft Slinger	Nitrile	Per Standard Water Well	Per Standard Water Well
Lead Wire	XLPE (#8 AWG) Hypalon (#4 & #2 AWG)	Per Standard Water Well	Per Standard Water Well
Lead Potting	Epoxy	Per Standard Water Well	Per Standard Water Well
Lead Jam Nut or Compression Plate	Brass Jam Nut (40-125 hp) 316 SS Plate (150-200 hp)	Per Standard Water Well	316 SS Jam Nut (40-125 hp) 316 SS Plate (150-200 hp)
Thrust Bearing Rating (86 °F / 30 °C)	10,000 lbs	Per Standard Water Well	Per Standard Water Well
Method Of Connecting System Ground To Motor	Ground Lug On Top End Bell	Per Standard Water Well	Per Standard Water Well

Specifications subject to change without notice. Contact Franklin Electric if current material types are required for bid specifications.

# 8" Submersible Motors Standard

## 8-Inch Models

HP (KW)	CONSTRUCTION	DESCRIPTION							MODEL	STOCK STATUS
		PH	VOLTS	HZ	SUBTROL HEAT SENSOR	S.F.	# LEADS	POWER WIRES		
<b>40 hp 30 kW</b>	WATER WELL	3P	380	60	YES	1.15	3	#8 w/o GND	239 660 60	
		3P	380	60	YES	1.15	6-90°	#8 w/o GND	239 680 20	
		3P	415	50	YES	1.00	3	#8 w/o GND	239 740 60	
		3P	460/380-415	60/50	YES	1.15/1.00	3	#8 w/o GND	239 600 60	YES
		3P	460/380-415	60/50	YES	1.15/1.00	6-90°	#8 w/o GND	239 620 20	
		3P	575	60	YES	1.15	3	#8 w/o GND	239 610 60	
	SAND FIGHTER	3P	380	60	YES	1.15	3	#8 w/o GND	239 660 85	
		3P	380	60	YES	1.15	6-90°	#8 w/o GND	239 680 86	
		3P	415	50	YES	1.00	3	#8 w/o GND	239 740 85	
		3P	460/380-415	60/50	YES	1.15/1.00	3	#8 w/o GND	239 600 85	YES
		3P	460/380-415	60/50	YES	1.15/1.00	6-90°	#8 w/o GND	239 620 86	
		3P	575	60	YES	1.15	3	#8 w/o GND	239 610 85	
	316 SS	3P	380	60	YES	1.15	3	#8 w/o GND	239 660 62	
		3P	380	60	YES	1.15	6-90°	#8 w/o GND	239 680 22	
		3P	415	50	YES	1.00	3	#8 w/o GND	239 740 62	
		3P	460/380-415	60/50	YES	1.15/1.00	3	#8 w/o GND	239 600 62	
		3P	460/380-415	60/50	YES	1.15/1.00	6-90°	#8 w/o GND	239 620 22	
		3P	575	60	YES	1.15	3	#8 w/o GND	239 610 62	
<b>50 hp 37 kW</b>	WATER WELL	3P	380	60	YES	1.15	3	#8 w/o GND	239 661 60	
		3P	380	60	YES	1.15	6-90°	#8 w/o GND	239 681 20	
		3P	415	50	YES	1.00	3	#8 w/o GND	239 741 60	
		3P	460/380-415	60/50	YES	1.15/1.00	3	#8 w/o GND	239 601 60	YES
		3P	460/380-415	60/50	YES	1.15/1.00	6-90°	#8 w/o GND	239 621 20	
		3P	575	60	YES	1.15	3	#8 w/o GND	239 611 60	
	SAND FIGHTER	3P	380	60	YES	1.15	3	#8 w/o GND	239 661 85	
		3P	380	60	YES	1.15	6-90°	#8 w/o GND	239 681 86	
		3P	415	50	YES	1.00	3	#8 w/o GND	239 741 85	
		3P	460/380-415	60/50	YES	1.15/1.00	3	#8 w/o GND	239 601 85	YES
		3P	460/380-415	60/50	YES	1.15/1.00	6-90°	#8 w/o GND	239 621 86	
		3P	575	60	YES	1.15	3	#8 w/o GND	239 611 85	
	316 SS	3P	380	60	YES	1.15	3	#8 w/o GND	239 661 62	
		3P	380	60	YES	1.15	6-90°	#8 w/o GND	239 681 22	
		3P	415	50	YES	1.00	3	#8 w/o GND	239 741 62	
		3P	460/380-415	60/50	YES	1.15/1.00	3	#8 w/o GND	239 601 62	YES
		3P	460/380-415	60/50	YES	1.15/1.00	6-90°	#8 w/o GND	239 621 22	
		3P	575	60	YES	1.15	3	#8 w/o GND	239 611 62	

# 8" Submersible Motors Standard

## 8-Inch Models

HP (KW)	CONSTRUCTION	DESCRIPTION							MODEL	STOCK STATUS
		PH	VOLTS	HZ	SUBTROL HEAT SENSOR	S.F.	# LEADS	POWER WIRES		
<b>60 hp 45 kW</b>	WATER WELL	3P	380	60	YES	1.15	3	#8 w/o GND	239 662 60	
		3P	380	60	YES	1.15	6-90°	#8 w/o GND	239 682 20	
		3P	415	50	YES	1.00	3	#8 w/o GND	239 742 60	
		3P	460/380-415	60/50	YES	1.15/1.00	3	#8 w/o GND	239 602 60	YES
		3P	460/380-415	60/50	YES	1.15/1.00	6-90°	#8 w/o GND	239 622 20	YES
		3P	575	60	YES	1.15	3	#8 w/o GND	239 612 60	YES
	SAND FIGHTER	3P	380	60	YES	1.15	3	#8 w/o GND	239 662 85	
		3P	380	60	YES	1.15	6-90°	#8 w/o GND	239 682 86	
		3P	415	50	YES	1.00	3	#8 w/o GND	239 742 85	
		3P	460/380-415	60/50	YES	1.15/1.00	3	#8 w/o GND	239 602 85	YES
		3P	460/380-415	60/50	YES	1.15/1.00	6-90°	#8 w/o GND	239 622 86	
		3P	575	60	YES	1.15	3	#8 w/o GND	239 612 85	
	316 SS	3P	380	60	YES	1.15	3	#8 w/o GND	239 662 62	
		3P	380	60	YES	1.15	6-90°	#8 w/o GND	239 682 22	
		3P	415	50	YES	1.00	3	#8 w/o GND	239 742 62	
		3P	460/380-415	60/50	YES	1.15/1.00	3	#8 w/o GND	239 602 62	YES
		3P	460/380-415	60/50	YES	1.15/1.00	6-90°	#8 w/o GND	239 622 22	
		3P	575	60	YES	1.15	3	#8 w/o GND	239 612 62	
<b>75 hp 55 kW</b>	WATER WELL	3P	380	60	YES	1.15	3	#4 w/o GND	239 663 60	YES
		3P	380	60	YES	1.15	6-90°	#4 w/o GND	239 683 20	
		3P	415	50	YES	1.00	3	#4 w/o GND	239 743 60	
		3P	460/380-415	60/50	YES	1.15/1.00	3	#4 w/o GND	239 603 60	YES
		3P	460/380-415	60/50	YES	1.15/1.00	6-90°	#4 w/o GND	239 623 20	YES
		3P	575	60	YES	1.15	3	#4 w/o GND	239 613 60	YES
	SAND FIGHTER	3P	380	60	YES	1.15	3	#4 w/o GND	239 663 85	
		3P	380	60	YES	1.15	6-90°	#4 w/o GND	239 683 86	
		3P	415	50	YES	1.00	3	#4 w/o GND	239 743 85	
		3P	460/380-415	60/50	YES	1.15/1.00	3	#4 w/o GND	239 603 85	YES
		3P	460/380-415	60/50	YES	1.15/1.00	6-90°	#4 w/o GND	239 623 86	
		3P	575	60	YES	1.15	3	#4 w/o GND	239 613 85	
	316 SS	3P	380	60	YES	1.15	3	#4 w/o GND	239 663 62	
		3P	380	60	YES	1.15	6-90°	#4 w/o GND	239 683 22	
		3P	415	50	YES	1.00	3	#4 w/o GND	239 743 62	
		3P	460/380-415	60/50	YES	1.15/1.00	3	#4 w/o GND	239 603 62	YES
		3P	460/380-415	60/50	YES	1.15/1.00	6-90°	#4 w/o GND	239 623 22	
		3P	575	60	YES	1.15	3	#4 w/o GND	239 613 62	

# 8" Submersible Motors Standard

## 8-Inch Models

HP (KW)	CONSTRUCTION	DESCRIPTION							MODEL	STOCK STATUS
		PH	VOLTS	HZ	SUBTROL HEAT SENSOR	S.F.	# LEADS	POWER WIRES		
<b>100 hp 75 kW</b>	WATER WELL	3P	380	60	YES	1.15	3	#4 w/o GND	239 664 60	YES
		3P	380	60	YES	1.15	6-90°	#4 w/o GND	239 684 20	
		3P	415	50	YES	1.00	3	#4 w/o GND	239 744 60	
		3P	460/380-415	60/50	YES	1.15/1.00	3	#4 w/o GND	239 604 60	YES
		3P	460/380-415	60/50	YES	1.15/1.00	6-90°	#4 w/o GND	239 624 20	YES
		3P	575	60	YES	1.15	3	#4 w/o GND	239 614 60	YES
	SAND FIGHTER	3P	380	60	YES	1.15	3	#4 w/o GND	239 664 85	
		3P	380	60	YES	1.15	6-90°	#4 w/o GND	239 684 86	
		3P	415	50	YES	1.00	3	#4 w/o GND	239 744 85	
		3P	460/380-415	60/50	YES	1.15/1.00	3	#4 w/o GND	239 604 85	YES
		3P	460/380-415	60/50	YES	1.15/1.00	6-90°	#4 w/o GND	239 624 86	
		3P	575	60	YES	1.15	3	#4 w/o GND	239 614 85	
	316 SS	3P	380	60	YES	1.15	3	#4 w/o GND	239 664 62	
		3P	380	60	YES	1.15	6-90°	#4 w/o GND	239 684 22	
		3P	415	50	YES	1.00	3	#4 w/o GND	239 744 62	
		3P	460/380-415	60/50	YES	1.15/1.00	3	#4 w/o GND	239 604 62	YES
		3P	460/380-415	60/50	YES	1.15/1.00	6-90°	#4 w/o GND	239 624 22	
		3P	575	60	YES	1.15	3	#4 w/o GND	239 614 62	
<b>125 hp 93 kW</b>	WATER WELL	3P	380	60	YES	1.15	3	#4 w/o GND	239 165 60	
		3P	380	60	YES	1.15	6-90°	#4 w/o GND	239 185 20	
		3P	415	50	YES	1.00	3	#4 w/o GND	274 365 60	
		3P	460/380-415	60/50	YES	1.15/1.00	3	#4 w/o GND	239 105 60	YES
		3P	460/380-415	60/50	YES	1.15/1.00	6-90°	#4 w/o GND	239 125 20	YES
		3P	575	60	YES	1.15	3	#4 w/o GND	239 115 60	YES
	SAND FIGHTER	3P	380	60	YES	1.15	3	#4 w/o GND	239 165 85	
		3P	380	60	YES	1.15	6-90°	#4 w/o GND	239 185 86	
		3P	415	50	YES	1.00	3	#4 w/o GND	239 365 85	
		3P	460/380-415	60/50	YES	1.15/1.00	3	#4 w/o GND	239 105 85	YES
		3P	460/380-415	60/50	YES	1.15/1.00	6-90°	#4 w/o GND	239 125 86	
		3P	575	60	YES	1.15	3	#4 w/o GND	239 115 85	
	316 SS	3P	380	60	YES	1.15	3	#4 w/o GND	239 165 62	
		3P	380	60	YES	1.15	6-90°	#4 w/o GND	239 185 22	
		3P	415	50	YES	1.00	3	#4 w/o GND	239 365 62	
		3P	460/380-415	60/50	YES	1.15/1.00	3	#4 w/o GND	239 105 62	YES
		3P	460/380-415	60/50	YES	1.15/1.00	6-90°	#4 w/o GND	239 125 22	
		3P	575	60	YES	1.15	3	#4 w/o GND	239 115 62	

# 8" Submersible Motors Standard

## 8-Inch Models

HP (KW)	CONSTRUCTION	DESCRIPTION							MODEL	STOCK STATUS
		PH	VOLTS	HZ	SUBTROL HEAT SENSOR	S.F.	# LEADS	POWER WIRES		
150 hp 110 kW	WATER WELL WITH SAND FIGHTER SEAL	3P	380	60	YES	1.15	3	#2 w/o GND	239 166 85	
		3P	380	60	YES	1.15	6-90°	#4 w/o GND	239 186 86	
		3P	415	50	YES	1.00	3	#2 w/o GND	239 366 85	
		3P	460/380-415	60/50	YES	1.15/1.00	3	#2 w/o GND	239 106 85	YES
		3P	460/380-415	60/50	YES	1.15/1.00	6-90°	#4 w/o GND	239 126 86	YES
		3P	575	60	YES	1.15	3	#2 w/o GND	239 116 85	YES
	316 SS	3P	380	60	YES	1.15	3	#2 w/o GND	239 166 62	
		3P	380	60	YES	1.15	6-90°	#4 w/o GND	239 186 22	
		3P	415	50	YES	1.00	3	#2 w/o GND	239 366 62	
		3P	460/380-415	60/50	YES	1.15/1.00	3	#2 w/o GND	239 106 62	YES
		3P	460/380-415	60/50	YES	1.15/1.00	6-90°	#4 w/o GND	239 126 22	
		3P	575	60	YES	1.15	3	#2 w/o GND	239 116 62	
175 hp 130 kW	WATER WELL WITH SAND FIGHTER SEAL	3P	380	60	YES	1.15	3	#2 w/o GND	239 167 85	
		3P	380	60	YES	1.15	6-90°	#4 w/o GND	239 187 86	
		3P	415	50	YES	1.00	3	#2 w/o GND	239 367 85	
		3P	460/380-415	60/50	YES	1.15/1.00	3	#2 w/o GND	239 107 85	YES
		3P	460/380-415	60/50	YES	1.15/1.00	6-90°	#4 w/o GND	239 127 86	
		3P	575	60	YES	1.15	3	#2 w/o GND	239 117 85	
	316 SS	3P	380	60	YES	1.15	3	#2 w/o GND	239 167 62	
		3P	380	60	YES	1.15	6-90°	#4 w/o GND	239 187 22	
		3P	415	50	YES	1.00	3	#2 w/o GND	239 367 62	
		3P	460/380-415	60/50	YES	1.15/1.00	3	#2 w/o GND	239 107 62	
		3P	460/380-415	60/50	YES	1.15/1.00	6-90°	#4 w/o GND	239 127 22	
		3P	575	60	YES	1.15	3	#2 w/o GND	239 117 62	
200 hp 150 kW	WATER WELL WITH SAND FIGHTER SEAL	3P	380	60	YES	1.15	3	#2 w/o GND	239 168 85	
		3P	380	60	YES	1.15	6-90°	#4 w/o GND	239 188 86	
		3P	415	50	YES	1.00	3	#2 w/o GND	239 368 85	
		3P	460/380-415	60/50	YES	1.15/1.00	3	#2 w/o GND	239 108 85	YES
		3P	460/380-415	60/50	YES	1.15/1.00	6-90°	#4 w/o GND	239 128 86	
		3P	575	60	YES	1.15	3	#2 w/o GND	239 118 85	
	316 SS	3P	380	60	YES	1.15	3	#2 w/o GND	239 168 62	
		3P	380	60	YES	1.15	6-90°	#4 w/o GND	239 188 22	
		3P	415	50	YES	1.00	3	#2 w/o GND	239 368 62	
		3P	460/380-415	60/50	YES	1.15/1.00	3	#2 w/o GND	239 108 62	
		3P	460/380-415	60/50	YES	1.15/1.00	6-90°	#4 w/o GND	239 128 22	
		3P	575	60	YES	1.15	3	#2 w/o GND	239 118 62	

### NOTES:

1. Models designated above as Sand Fighter™ are water well construction.
2. All 316 ss models are equipped with Sand Fighter sealing system.
3. All models listed above include factory installed leads (13 ft).
4. Motor leads do not include ground.

## 8" Submersible Motors Hi-Temp 75



### Applications

These motors are built for dependable operation in vertical 8" diameter or larger wells, in applications with higher temperature, higher thrust or low flow.

### Basic Features

- Able to operate in water temperatures up to 167 °F (75 °C)
- In 86 °F (30 °C) ambient or less they supply 25% more downthrust and upthrust than standard product
- No flow capable when submerged in lakes or wells 14" diameter or larger and water 86 °F or less
- Double flanged NEMA mounting design
- Stainless steel splined shaft
- StatorShield™ Franklin's six feature encapsulation system
- High capacity Kingsbury type water lubricated thrust bearing
- Factory filled with Franklin's non-toxic water soluble fill solution
- Field replaceable lead using Franklin's exclusive Water Bloc™ technology
- Full 3525 rpm 60 Hz design point
- External sand slinger on shaft
- Sand Fighter™ mechanical face seal system at shaft exit
- Copper bar rotor
- All models variable frequency drive (VFD) approved

### Special Options

- SubMonitor™ is a state-of-the-art electronic motor overload that is sold separately.
  - Mounts in the above ground panel requiring no additional wiring to the motor.
  - User friendly, field proven.
  - Protection monitors for balanced power, overload, underload, overheating, rapid cycling and more.
  - Can be used with or without a SubTrol™ heat sensor.
  - Supplies superior heat protection when manufactured with the SubTrol heat sensor.

Consult factory for other voltage, hertz and horsepower ratings not listed in this catalog. Specifications are subject to change without notice. Contact Franklin Electric if current materials are required for bid specifications.

# 8" Submersible Motors Hi-Temp 75

## Hi-Temp 75 8-Inch Three-Phase Motor Specifications

Hz	Phase	Hp Range	kW Range	Poles	RPM	Max. Ambient Temp.	Duty Rating
60	3	40 - 150	30 - 110	2	3525	167 °F / 75 °C	Continuous at 0.5 ft/sec flow past motor*
50	3	40 - 150	30 - 110	2	2900	167 °F / 75 °C	Continuous at 0.5 ft/sec flow past motor*

\* Motors are also rated for continuous duty in 86 °F (30 °C) maximum water temperature with NO FLOW in lakes or in wells 14 inches or larger in diameter.

## Hi-Temp 75 8-Inch Construction Materials

Component	Construction Type	
	Hi-Temp 75 (300 SS Series Shell)	Hi-Temp 75 (316 SS Construction)
UL Insulation Class Rating	Class F	Class F
Motor Ambient Temperature Rating	167 °F / 75 °C	167 °F / 75 °C
Stator Resin Type	FE Hi-Temp	FE Hi-Temp
Motor Fill Solution (Water Soluble/Non-Toxic)	FES92	FES92
Top End Bell & Thrust Housing	Epoxy Coated Gray Iron	316 SS
SubTrol™ heat sensor (Mounted On Winding)	No	No
Stator Shell	300 SS Series	316 SS
Stator Ends	Carbon Steel	316 SS
Shaft Extension	17-4 SS	17-4 SS
Bushing	Bronze	316 SS
Bushing Retainer	300 SS Series	316 SS
Shaft Mechanical Seal	Sand Fighter™ Seal System	Sand Fighter Seal System
Mechanical Seal Rubber Components	Viton®	Viton®
Diaphragm Material	Viton®	Viton®
Diaphragm Plate	316 SS	316 SS
Diaphragm Spring	316 SS	316 SS
Shaft Slinger	Viton®	Viton®
Lead Wire	XLPO	XLPO
Lead Potting	Epoxy	Epoxy
Lead Jam Nut or Compression Plate	316 SS Plate (150-200 hp)	316 SS Plate (150-200 hp)
Thrust Bearing Rating (86 °F / 30 °C)	12,500 lbs (86 °F / 30 °C) 10,000 lbs (167 °F / 75 °C)	12,500 lbs (86 °F / 30 °C) 10,000 lbs (167 °F / 75 °C)
Method Of Connecting System Ground To Motor	Ground Lug On Top End Bell	Ground Lug On Top End Bell

Specifications subject to change without notice. Contact Franklin Electric if current material types are required for bid specifications.

Viton® is a registered trademark of DuPont Dow Elastomers.

# 8" Submersible Motors Hi-Temp 75

## 8-Inch Hi-Temp 75 Dimensions and Weights

### 40 hp to 150 hp Type 1.0

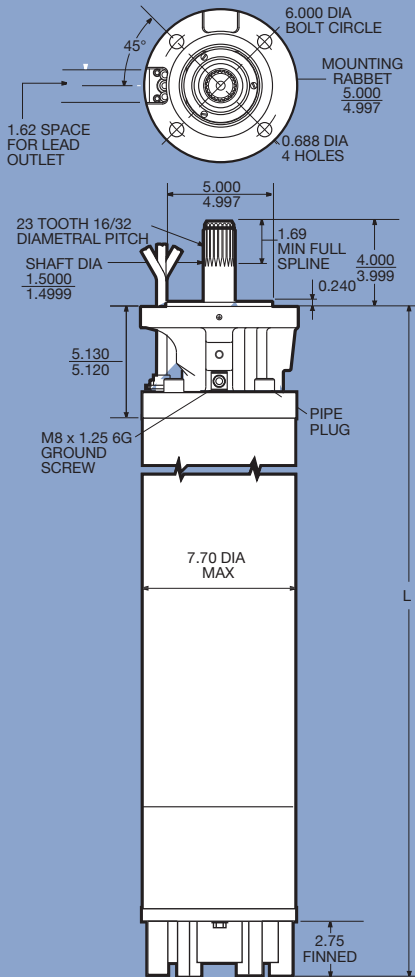

### Three-Phase Motors

HP	KW	"L" (inches)	SHIPPING WEIGHT		MOTOR CARTON SIZE (in inches)
			LBS	KG	
40	30	44.8	400	181	17 x 9.25 x 51
50	37	49.8	455	206	17 x 9.25 x 64
60	45	57.3	555	252	17 x 9.25 x 64
75	55	68.8	700	318	17 x 9.25 x 79
100	75	77.8	840	382	17 x 9.25 x 96
125	93	85.8	945	430	17 x 9.25 x 96
150	110	94.8	1040	473	17 x 9.25 x 108

# 8" Submersible Motors Hi-Temp 75

## 8-Inch Hi-Temp 75 Models

HP (KW)	CONSTRUCTION	DESCRIPTION							MODEL	STOCK STATUS
		PH	VOLTS	HZ	SUBTROL HEAT SENSOR	S.F.	# LEADS	WIRE SIZE		
40 hp 30 kW	WATER WELL WITH SAND FIGHTER SEAL	3P	380	60	Not Available	1.15	3	#2 w/o GND	279 160 90	
		3P	380	60	Not Available	1.15	6-90°	#2 w/o GND	279 180 90	
		3P	415	50	Not Available	1.00	3	#2 w/o GND	279 360 90	
		3P	460/380-415	60/50	Not Available	1.15/1.00	3	#2 w/o GND	279 100 90	
		3P	460/380-415	60/50	Not Available	1.15/1.00	6-90°	#2 w/o GND	279 120 90	
		3P	575	60	Not Available	1.15	3	#2 w/o GND	279 110 90	
	316 SS	3P	380	60	Not Available	1.15	3	#2 w/o GND	279 160 92	
		3P	380	60	Not Available	1.15	6-90°	#2 w/o GND	279 180 92	
		3P	415	50	Not Available	1.00	3	#2 w/o GND	279 360 92	
		3P	460/380-415	60/50	Not Available	1.15/1.00	3	#2 w/o GND	279 100 92	
		3P	460/380-415	60/50	Not Available	1.15/1.00	6-90°	#2 w/o GND	279 120 92	
		3P	575	60	Not Available	1.15	3	#2 w/o GND	279 110 92	
50 hp 37 kW	WATER WELL WITH SAND FIGHTER SEAL	3P	380	60	Not Available	1.15	3	#2 w/o GND	279 161 90	
		3P	380	60	Not Available	1.15	6-90°	#2 w/o GND	279 181 90	
		3P	415	50	Not Available	1.00	3	#2 w/o GND	279 361 90	
		3P	460/380-415	60/50	Not Available	1.15/1.00	3	#2 w/o GND	279 101 90	
		3P	460/380-415	60/50	Not Available	1.15/1.00	6-90°	#2 w/o GND	279 121 90	
		3P	575	60	Not Available	1.15	3	#2 w/o GND	279 111 90	
	316 SS	3P	380	60	Not Available	1.15	3	#2 w/o GND	279 161 92	
		3P	380	60	Not Available	1.15	6-90°	#2 w/o GND	279 181 92	
		3P	415	50	Not Available	1.00	3	#2 w/o GND	279 361 92	
		3P	460/380-415	60/50	Not Available	1.15/1.00	3	#2 w/o GND	279 101 92	
		3P	460/380-415	60/50	Not Available	1.15/1.00	6-90°	#2 w/o GND	279 121 92	
		3P	575	60	Not Available	1.15	3	#2 w/o GND	279 111 92	
60 hp 45 kW	WATER WELL WITH SAND FIGHTER SEAL	3P	380	60	Not Available	1.15	3	#2 w/o GND	279 162 90	
		3P	380	60	Not Available	1.15	6-90°	#2 w/o GND	279 182 90	
		3P	415	50	Not Available	1.00	3	#2 w/o GND	279 362 90	
		3P	460/380-415	60/50	Not Available	1.15/1.00	3	#2 w/o GND	279 102 90	YES
		3P	460/380-415	60/50	Not Available	1.15/1.00	6-90°	#2 w/o GND	279 122 90	
		3P	575	60	Not Available	1.15	3	#2 w/o GND	279 112 90	
	316 SS	3P	380	60	Not Available	1.15	3	#2 w/o GND	279 162 92	
		3P	380	60	Not Available	1.15	6-90°	#2 w/o GND	279 182 92	
		3P	415	50	Not Available	1.00	3	#2 w/o GND	279 362 92	
		3P	460/380-415	60/50	Not Available	1.15/1.00	3	#2 w/o GND	279 102 92	
		3P	460/380-415	60/50	Not Available	1.15/1.00	6-90°	#2 w/o GND	279 122 92	
		3P	575	60	Not Available	1.15	3	#2 w/o GND	279 112 92	

# 8" Submersible Motors Hi-Temp 75

## 8-Inch Hi-Temp 75 Models

HP (KW)	CONSTRUCTION	DESCRIPTION							MODEL	STOCK STATUS
		PH	VOLTS	HZ	SUBTROL HEAT SENSOR	S.F.	# LEADS	WIRE SIZE		
75 hp 55 kW	WATER WELL WITH SAND FIGHTER SEAL	3P	380	60	Not Available	1.15	3	#2 w/o GND	279 163 90	
		3P	380	60	Not Available	1.15	6-90°	#2 w/o GND	279 183 90	
		3P	415	50	Not Available	1.00	3	#2 w/o GND	279 363 90	
		3P	460/380-415	60/50	Not Available	1.15/1.00	3	#2 w/o GND	279 103 90	YES
		3P	460/380-415	60/50	Not Available	1.15/1.00	6-90°	#2 w/o GND	279 123 90	
		3P	575	60	Not Available	1.15	3	#2 w/o GND	279 113 90	
	316 SS	3P	380	60	Not Available	1.15	3	#2 w/o GND	279 163 92	
		3P	380	60	Not Available	1.15	6-90°	#2 w/o GND	279 183 92	
		3P	415	50	Not Available	1.00	3	#2 w/o GND	279 363 92	
		3P	460/380-415	60/50	Not Available	1.15/1.00	3	#2 w/o GND	279 103 92	
		3P	460/380-415	60/50	Not Available	1.15/1.00	6-90°	#2 w/o GND	279 123 92	
		3P	575	60	Not Available	1.15	3	#2 w/o GND	279 113 92	
100 hp 75 kW	WATER WELL WITH SAND FIGHTER SEAL	3P	380	60	Not Available	1.15	3	#2 w/o GND	279 164 90	
		3P	380	60	Not Available	1.15	6-90°	#2 w/o GND	279 184 90	
		3P	415	50	Not Available	1.00	3	#2 w/o GND	279 364 90	
		3P	460/380-415	60/50	Not Available	1.15/1.00	3	#2 w/o GND	279 104 90	YES
		3P	460/380-415	60/50	Not Available	1.15/1.00	6-90°	#2 w/o GND	279 124 90	
		3P	575	60	Not Available	1.15	3	#2 w/o GND	279 114 90	
	316 SS	3P	380	60	Not Available	1.15	3	#2 w/o GND	279 164 92	
		3P	380	60	Not Available	1.15	6-90°	#2 w/o GND	279 184 92	
		3P	415	50	Not Available	1.00	3	#2 w/o GND	279 364 92	
		3P	460/380-415	60/50	Not Available	1.15/1.00	3	#2 w/o GND	279 104 92	YES
		3P	460/380-415	60/50	Not Available	1.15/1.00	6-90°	#2 w/o GND	279 124 92	
		3P	575	60	Not Available	1.15	3	#2 w/o GND	279 114 92	
125 hp 93 kW	WATER WELL WITH SAND FIGHTER SEAL	3P	380	60	Not Available	1.15	3	#2 w/o GND	279 165 90	
		3P	380	60	Not Available	1.15	6-90°	#2 w/o GND	279 185 90	
		3P	415	50	Not Available	1.00	3	#2 w/o GND	279 365 90	
		3P	460/380-415	60/50	Not Available	1.15/1.00	3	#2 w/o GND	279 105 90	YES
		3P	460/380-415	60/50	Not Available	1.15/1.00	6-90°	#2 w/o GND	279 125 90	
		3P	575	60	Not Available	1.15	3	#2 w/o GND	279 115 90	
	316 SS	3P	380	60	Not Available	1.15	3	#2 w/o GND	279 165 92	
		3P	380	60	Not Available	1.15	6-90°	#2 w/o GND	279 185 92	
		3P	415	50	Not Available	1.00	3	#2 w/o GND	279 365 92	
		3P	460/380-415	60/50	Not Available	1.15/1.00	3	#2 w/o GND	279 105 92	YES
		3P	460/380-415	60/50	Not Available	1.15/1.00	6-90°	#2 w/o GND	279 125 92	
		3P	575	60	Not Available	1.15	3	#2 w/o GND	279 115 92	

# 8" Submersible Motors 316SS Booster

## 8-Inch Hi-Temp 75 Models

HP (KW)	CONSTRUCTION	DESCRIPTION							MODEL	STOCK STATUS
		PH	VOLTS	HZ	SUBTROL HEAT SENSOR	S.F.	# LEADS	WIRE SIZE		
<b>150 hp 110 kW</b>	WATER WELL WITH SAND FIGHTER SEAL	3P	380	60	Not Available	1.15	3	#2 w/o GND	279 166 90	
		3P	380	60	Not Available	1.15	6-90°	#2 w/o GND	279 186 90	
		3P	415	50	Not Available	1.00	3	#2 w/o GND	279 366 90	
		3P	460/380-415	60/50	Not Available	1.15/1.00	3	#2 w/o GND	279 106 90	YES
		3P	460/380-415	60/50	Not Available	1.15/1.00	6-90°	#2 w/o GND	279 126 90	
		3P	575	60	Not Available	1.15	3	#2 w/o GND	279 116 90	
	316 SS	3P	380	60	Not Available	1.15	3	#2 w/o GND	279 166 92	
		3P	380	60	Not Available	1.15	6-90°	#2 w/o GND	279 186 92	
		3P	415	50	Not Available	1.00	3	#2 w/o GND	279 366 92	
		3P	460/380-415	60/50	Not Available	1.15/1.00	3	#2 w/o GND	279 106 92	
		3P	460/380-415	60/50	Not Available	1.15/1.00	6-90°	#2 w/o GND	279 126 92	
		3P	575	60	Not Available	1.15	3	#2 w/o GND	279 116 92	

**NOTES:**

1. All models listed above include leads (13 ft).
2. Motor leads do not include ground.

# 8" Submersible Motors Leads

**FIGURE 1: Standard XLPE 125 °C Lead**

Motor construction for 40, 50 & 60 hp

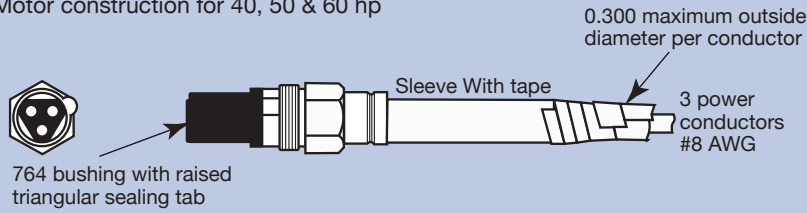

**FIGURE 2: Standard Hypalon 75 °C Lead**

Motor construction for 75, 100 & 125 hp

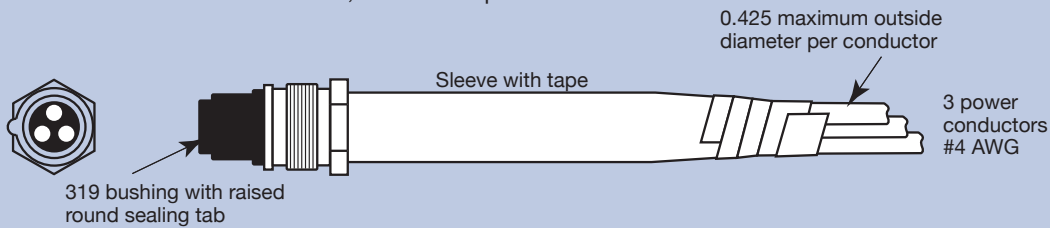

**FIGURE 3: Standard Hypalon 75 °C Lead**

Motor construction for 150, 175 & 200 hp lead clamping plate is a separate part and can be reused

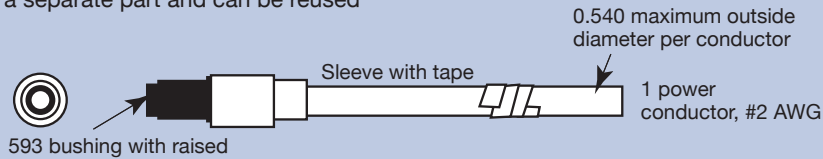

FIGURE	FITS FE MOTOR RATING (460 V or 575 V 60 Hz)	JAM NUT MATERIAL	LEAD LENGTH		WIRE SIZE (AWG)	POWER CONDUCTOR PER CONNECTOR	FE PART NUMBER	REPLACEMENT KIT NUMBER
			FT	M				
1	40-60 hp 30-45 kW	Brass	13	4	#8	3 (1 Shipped) No Ground	152 698 901	305 516 901
		Brass	26	8	#8	3 (1 Shipped) No Ground	152 698 902	305 516 902
		316 SS	13	4	#8	3 (1 Shipped) No Ground	152 698 950	305 516 950
		316 SS	26	8	#8	3 (1 Shipped) No Ground	152 698 951	305 516 951
2	75-125 hp 55-93 kW	Brass	13	4	#4	3 (1 Shipped) No Ground	165 238 901	305 210 901
		Brass	26	8	#4	3 (1 Shipped) No Ground	165 238 924	305 210 924
		316 SS	13	4	#4	3 (1 Shipped) No Ground	165 238 903	305 210 903
		316 SS	26	8	#4	3 (1 Shipped) No Ground	165 238 928	305 210 928
3	150-200 hp 110-150 kW	316 SS	13	4	#2	1 (3 shipped) No Ground	165 617 901	305 315 901
		316 SS	26	8	#2	1 (3 shipped) No Ground	165 617 902	305 315 902

# 8" Submersible Motors Leads

## 8-Inch 125 °C XLPO Hi-Temp 75C and Booster Motor Leads

FITS FE MOTOR RATING (460 V or 575 V 60 Hz)	JAM NUT MATERIAL	LEAD LENGTH		WIRE SIZE (AWG)	POWER WIRES	FE PART NUMBER	REPLACEMENT KIT NUMBER
		FT	M				
<b>All Ratings</b>	316 SS	13	4	#2	1 (3 shipped) No Ground	165 617 901	305 315 901
	316 SS	26	8	#2	1 (3 shipped) No Ground	165 617 902	305 315 902

## 8-Inch Lead Construction Materials

Component	Material
Wire	RHW Hypalon 75°, or XLPO 125 °C
Sleeve	Brass or 316 SS
Potting	Epoxy
Jam Nut or Clamp Plate	Brass or 316 SS

Specifications subject to change without notice. Contact Franklin Electric if current material types are required for bid specifications.

# Submersible Motor Control Boxes



## Applications

### QUICK DISCONNECT (QD) & CAPACITOR RUN CONTROL (CRC)

– These control boxes are designed for use with Franklin 3-wire single-phase submersible motors through 1 hp.

**STANDARD & DELUXE** – These control boxes are designed for use with Franklin 3-wire single-phase submersible motors from 1 through 15 hp. Recommended for water systems that use pressure switches, level switches, or other pilot devices. Deluxe boxes (only) contain magnetic line contactors carefully matched to the motor rating, eliminating the need for external line contactors.

## Basic Features – All Boxes

- Suitable for outdoor mounting
- Capacitor Start / Capacitor Run design (except QD boxes)
- UL Listed for US and Canada (60 Hz models)

## Basic Features – Standard & Deluxe Boxes

- Heavy duty box-type terminals accept up to AWG #2 wire
- External access to overload resets
- Multiple-size knockouts
- User-friendly connection diagrams
- Easy access to grounding lugs

## Single-Phase Control Box Specifications

BOX TYPE	HZ	HP RANGE	KW RANGE	ENCLOSURE	TERMINAL BLOCK		MAG CONTACTOR	AGENCY APPROVALS
					TERMINALS	MAX WIRE		
Quick Disconnect (QD)	60	1/3 - 1	0.25 - 0.75	NEMA 3R, IP23	5	AWG 10	No	UL listed for US and Canada
Quick Disconnect (QD)	50	1/3 - 1	0.25 - 0.75	NEMA 3R, IP23	5	AWG 10	No	CSA Certified
Capacitor Run Control (CRC)	60	1/2 - 1	0.37 - 0.75	NEMA 3R, IP23	5	AWG 10	No	UL listed for US and Canada
Standard (S)	60	1 - 10	0.75 - 7.5	NEMA 3R, IP23	5	AWG 2	No	UL listed for US and Canada
Standard (S)	50	1.5 - 5	0.75 - 3.7	NEMA 3R, IP23	5	AWG 2	No	CSA Certified
Deluxe (D)	60	2 - 15	1.5 - 11	NEMA 3R, IP23	6	AWG 2	Yes	UL listed for US and Canada
Extra Large Deluxe (D-XL)	60	15	11	NEMA 3R, IP23	5	AWG 00	Yes	UL listed for US and Canada

# Submersible Motor Control Boxes

## Enclosure – Quick Disconnect (QD) & Capacitor Run Control (CRC) Boxes

### ■ Knockouts:

- Bottom: Two 0.88” knockouts and one 1.31” knockout.
- Side: One 0.88” knockout and one 1.31” knockout on each side.

- **Terminal Block:** five terminals provided for wiring up to AWG #10 wire.

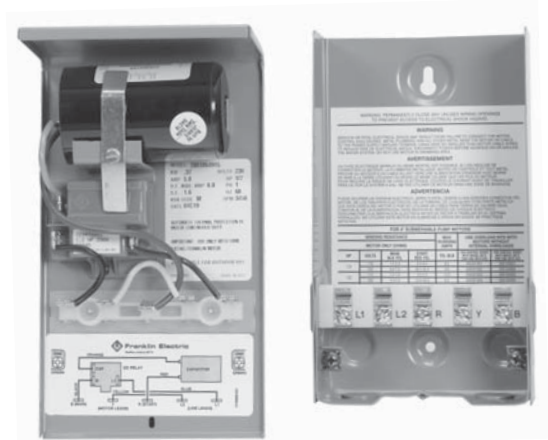

### Quick Disconnect (QD) Control Boxes

HP	KW	SHIPPING WEIGHT		MOTOR CARTON SIZE (in inches)	ENC SIZE
		LBS	KG		
1/3	0.25	4	1.8	5.5 x 3.25 x 9	QD
1/2	0.37	4	1.8	5.5 x 3.25 x 9	QD
3/4	0.55	4	1.8	5.5 x 3.25 x 9	QD
1	0.75	4	1.8	5.5 x 3.25 x 9	QD

### Capacitor Run Control (CRC) Boxes

HP	KW	SHIPPING WEIGHT		MOTOR CARTON SIZE (in inches)	ENC SIZE
		LBS	KG		
1/2	0.37	5	2.3	5.5 x 3.25 x 9	QD
3/4	0.55	5	2.3	5.5 x 3.25 x 9	QD
1	0.75	5	2.3	5.5 x 3.25 x 9	QD

QD Box Dimensions

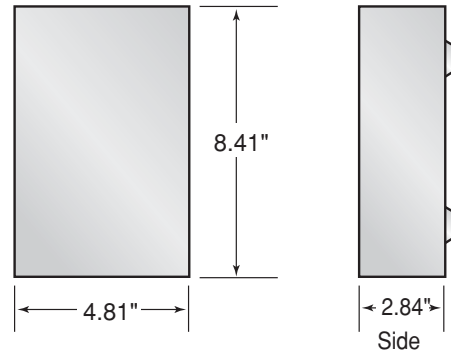

# Submersible Motor Control Boxes

## Enclosure - Standard & Deluxe Boxes

- **Knockouts:** Two 1.31" diameter holes for 1" conduit connection. One 1.75" knockout for 1.25" conduit. One 0.88" knockout for 0.5" conduit connection.
- **Terminal Block:** six terminals provided for wiring up to AWG 2 wire.



## Standard & Deluxe Dimensions

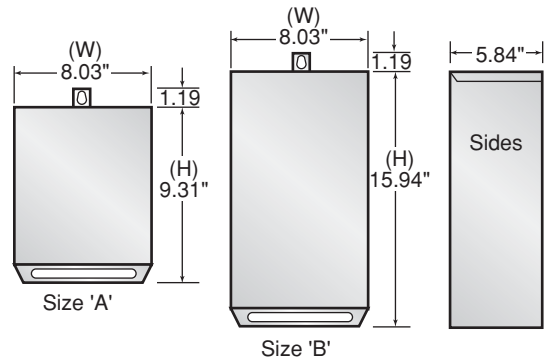

## Standard Control Boxes

HP	KW	SHIPPING WEIGHT		MOTOR CARTON SIZE (in inches)	ENC SIZE
		LBS	KG		
1.5	1.1	7	3.2	8.125 x 6.25 x 11.25	A
2	1.5	7	3.2	8.125 x 6.25 x 11.25	A
3	2.2	7	3.2	8.125 x 6.25 x 11.25	A
5 (60 Hz)	3.7	8	3.6	8.125 x 6.25 x 11.25	A
5 (50 Hz)	3.7	8	3.6	8.125 x 6.25 x 18	B
7.5	5.5	12	5.5	8.125 x 6.25 x 18	B
10	7.5	14	6.4	8.125 x 6.25 x 18	B

## Deluxe Control Boxes

HP	KW	SHIPPING WEIGHT		MOTOR CARTON SIZE (in inches)	ENC SIZE
		LBS	KG		
2	1.5	7.0	3.2	8.125 x 6.25 x 11.25	A
3	2.2	7.3	3.3	8.125 x 6.25 x 11.25	A
5	3.7	11.2	5.1	8.125 x 6.25 x 18	B
7.5	5.5	13.1	6.0	8.125 x 6.25 x 18	B
10	7.5	14.7	6.7	8.125 x 6.25 x 18	B
15	11	16.5	7.5	8.125 x 6.25 x 18	B
15 (XL)	11	28.0	12.7	16 x 7.125 x 19	C

# Submersible Motor Control Boxes

## Enclosure - Extra Large Deluxe (D-XL) Boxes

### ■ Knockouts:

- Bottom: two knockouts for 0.75" conduit, and two for 1.5" conduit.
- Side: one knockout for 2" conduit.

■ **Terminal Block:** two terminals provided for incoming power and three terminals provided for drop cable for conductors from AWG 14 to 00.

■ **Control Switch Terminal Block:** accepts conductors from AWG 20 to 6.

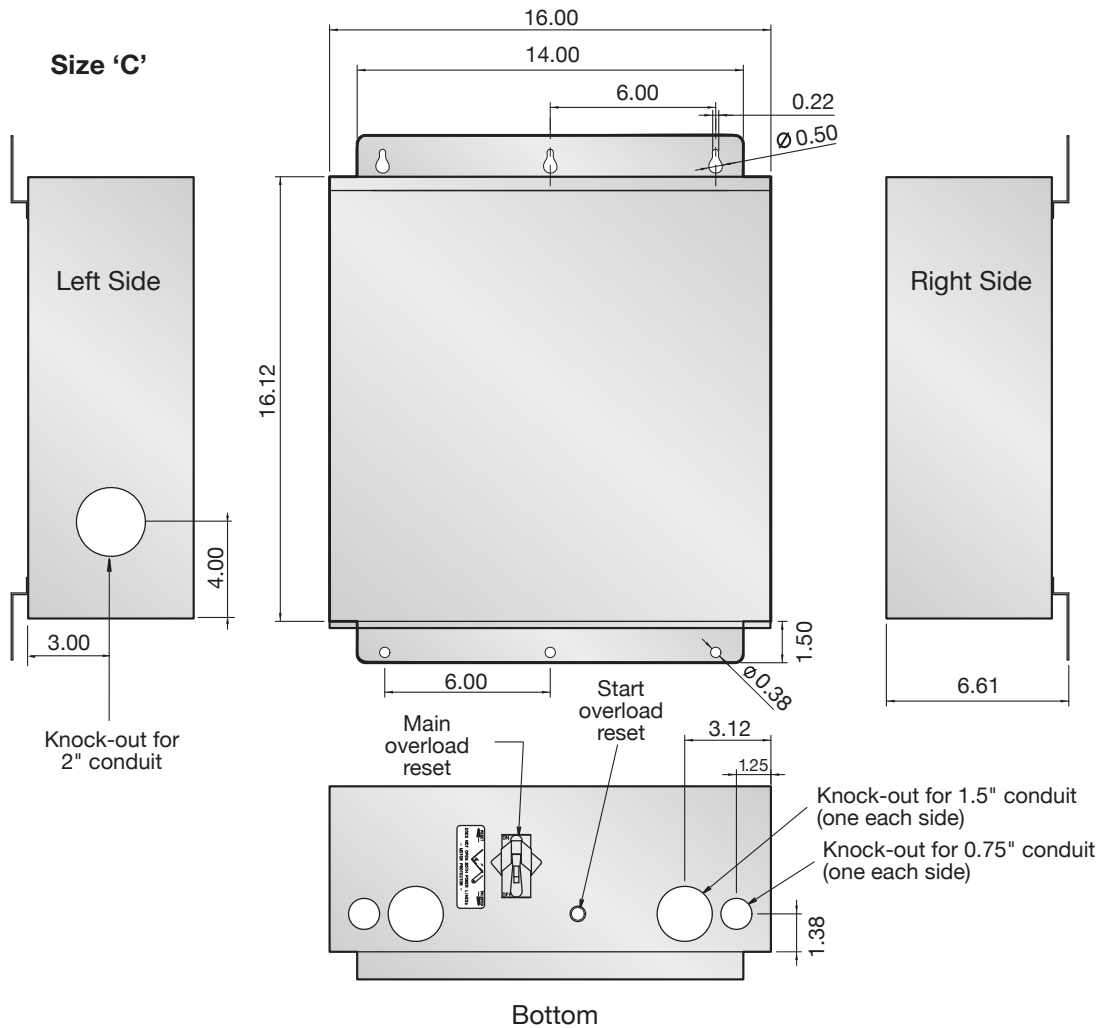
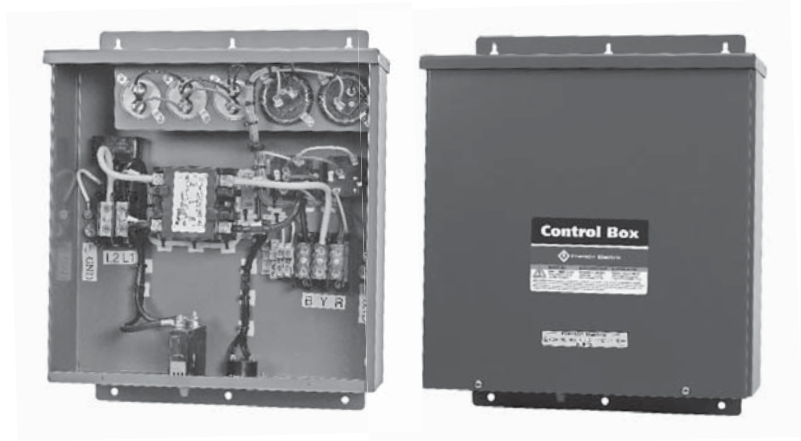

# Submersible Motor Control Boxes

## Control Box Models

HP (KW)	DESCRIPTION				MODEL	STOCK STATUS
	PH	VOLTS	HZ	TYPE		
<b>1/3 hp (0.25 kW)</b>	1P	115	60	Q	280 102 4915	YES
	1P	220	50	Q	280 353 0115	
	1P	230	60	Q	280 103 4915	YES
<b>1/2 hp (0.37 kW)</b>	1P	115	60	Q	280 104 4915	YES
	1P	220	50	Q	280 355 0115	YES
	1P	230	60	Q	280 105 4915	YES
	1P	230	60	CRC	282 405 5015	YES
<b>3/4 hp (0.55 kW)</b>	1P	220	50	Q	280 357 0115	YES
	1P	230	60	Q	280 107 4915	YES
	1P	230	60	CRC	282 407 5015	YES
<b>1 hp (0.75 kW)</b>	1P	220	50	Q	280 358 0115	YES
	1P	230	60	Q	280 108 4915	YES
	1P	230	60	CRC	282 408 5015	YES
<b>1.5 hp (1.1 kW)</b>	1P	220	50	S	282 350 8110	YES
	1P	230	60	S	282 300 8110	YES
<b>2 hp (1.5 kW)</b>	1P	220	50	S	282 351 8110	YES
	1P	230	60	S	282 301 8110	YES
	1P	230	60	D	282 301 8310	YES
<b>3 hp (2.2 kW)</b>	1P	220	50	S	282 352 8110	YES
	1P	230	60	S	282 302 8110	YES
	1P	230	60	D	282 302 8310	YES
<b>5 hp (3.7 kW)</b>	1P	220	50	S	282 253 9010	YES
	1P	230	60	S	282 113 8110	YES
	1P	230	60	D	282 113 9310	YES
<b>7.5 hp (5.5 kW)</b>	1P	230	60	S	282 201 9210	YES
	1P	230	60	D	282 201 9310	YES
<b>10 hp (7.5 kW)</b>	1P	230	60	S	282 202 9230	YES
	1P	230	60	D	282 202 9330	YES
<b>15 hp (11 kW)</b>	1P	230	60	D	282 203 9330	YES
	1P	230	60	D-XL	282 203 9621	

### NOTES:

Q = Quick Disconnect Control Box

CRC = Capacitor Run Control Box

S = Standard Control Box

D = Deluxe Control Box

D-XL = Extra Large Deluxe Control Box

# Submersible Motor Control Boxes

## Control Box Parts

### QD Control Box Parts - 60 Hz

HP Voltage Model No.	Rating	No. Req.	Component Part No.	Kit Order No.
1/3 hp - 115 V 280 102 4915	Start Capacitor 159-191 MFD, 110 V	1	275 464 125	305 207 925
	QD Relay	1	223 415 905	305 101 905
1/3 hp - 230 V 280 103 4915	Start Capacitor 43-53 MFD, 220 V	1	275 464 126	305 207 926
	QD Relay	1	223 415 901	305 101 901
1/2 hp - 115 V 280 104 4915	Start Capacitor 250-300 MFD, 125 V	1	275 464 201	305 207 951
	QD Relay	1	223 415 906	305 101 906
1/2 hp - 230 V 280 105 4915	Start Capacitor 59-71 MFD, 220 V	1	275 464 105	305 207 905
	QD Relay	1	223 415 902	305 101 902
3/4 hp - 230 V 280 107 4915	Start Capacitor 86-103 MFD, 220 V	1	275 464 118	305 207 918
	QD Relay	1	223 415 903	305 101 903
1 hp - 230 V 280 108 4915	Start Capacitor 105-126 MFD, 220 V	1	275 464 113	305 207 913
	QD Relay	1	223 415 904	305 101 904
1/2 hp - 230 V CRC 282 405 5015	Start Capacitor 43-53 MFD, 220 V	1	275 464 126	305 207 926
	Run Capacitor 15 MFD, 370 V	1	156 362 101	305 203 907
	QD Relay	1	223 415 912	305 105 901
3/4 hp - 230 V CRC 282 407 5015	Start Capacitor 59-71 MFD, 220 V	1	275 464 105	305 207 905
	Run Capacitor 23 MFD, 370 V	1	156 362 102	305 203 908
	QD Relay	1	223 415 913	305 105 902
1 hp - 230 V CRC 282 408 5015	Start Capacitor 86-103 MFD, 220 V	1	275 464 118	305 207 918
	Run Capacitor 23 MFD, 370 V	1	156 362 102	305 203 908
	QD Relay	1	223 415 914	305 105 903

### QD Control Box Parts - 50 Hz

HP Voltage Model No.	Rating	No. Req.	Component Part No.	Kit Order No.
1/3 hp - 220 V 280 353 0115	Start Capacitor 43-53 MFD, 220 V	1	275 461 123	305 205 923
	Capacitor Overload Assembly	1	151 033 957	305 218 957
	Relay 220 V	1	155 031 112	305 213 912
1/2 hp - 220 V 280 355 0115	Start Capacitor 43-53 MFD, 220 V	1	275 461 123	305 205 923
	Capacitor Overload Assembly	1	151 033 957	305 218 957
	Relay 220 V	1	155 031 112	305 213 912
3/4 hp - 220 V 280 357 0115	Start Capacitor 59-71 MFD, 220 V	1	275 461 108	305 205 908
	Capacitor Overload Assembly	1	151 033 918	305 218 918
	Relay 220 V	1	155 031 112	305 213 912
1 hp - 220 V 280 358 0115	Start Capacitor 86-103 MFD, 220V	1	275 461 106	305 205 906
	Capacitor Overload Assembly	1	151 033 906	305 218 906
	Relay 220 V	1	155 031 112	305 213 912

### Replacement Parts for Older Style QD Control Boxes

Description	Rating	No. Req.	Component Part No.	Kit Order No.
Voltage Relay Kit	115 Volt with bracket and screws	1	155 031 901	305 102 901
	230 Volt with bracket and screws	1	155 031 902	305 102 902
	208 Volt with bracket and screws	1	155 031 903	305 102 903
Capacitor Overload Assembly	1/3 hp, 115 Volt	1	151 033 973	305 218 973
	1/3 hp, 230 Volt	1	151 033 974	305 218 974
	1/2 hp, 115 Volt	1	151 033 975	305 218 975
	1/2 hp, 230 Volt	1	151 033 976	305 218 976
	3/4 hp, 230 Volt	1	151 033 978	305 218 978
	1 hp, 230 Volt	1	151 033 979	305 218 979
Overload Kit	1.5 hp, 230 Volt	1	151 033 980	305 218 980
	1/3 hp, 115 Volt	1	NA	305 100 901
	1/3 hp, 230 Volt	1	NA	305 100 902
	1/2 hp, 115 Volt	1	NA	305 100 903
	1/2 hp, 230 Volt	1	NA	305 100 904
	3/4 hp, 230 Volt	1	NA	305 100 905
	1 hp, 230 Volt	1	NA	305 100 906

**NOTE:** Some Franklin motors, controls & parts are not stock items and may need to be special ordered.

# Submersible Motor Control Boxes

## Control Box Parts

### Standard Control Box Parts - 60 Hz

HP Size Model No.	Rating	No. Req.	Component Part No.	Kit Order No.
<b>1/1.5 hp - 4"</b> 282 300 8110	Start Capacitor 105-126 MFD, 220 V	1	275 464 113	305 207 913
	Run Capacitor 10 MFD, 370 V	1	155 328 102	305 204 902
	Overload	1	275 411 107	305 215 907
	Relay - 230 V*	1	155 031 102	305 213 902
<b>2 hp - 4"</b> 282 301 8110	Start Capacitor 105-126 MFD, 220 V	1	275 464 113	305 207 913
	Run Capacitor 20 MFD, 370 V	1	155 328 103	305 204 903
	Start Overload	1	275 411 117	305 215 917
	Run Overload	1	275 411 113	305 215 913
	Relay - 230 V*	1	155 031 102	305 213 902
<b>3 hp - 4"</b> 2823028110	Start Capacitor 208-250 MFD, 220 V	1	275 463 111	305 206 911
	Run Capacitor 45 MFD, 370 V	1	155 327 109	305 203 909
	Start Overload	1	275 411 118	305 215 918
	Run Overload	1	275 411 115	305 215 915
	Relay - 230 V*	1	155 031 102	305 213 902
<b>5 hp - 4" &amp; 6"</b> 282 113 8110	Start Capacitor 270-324 MFD, 330 V	1	275 468 119	305 208 919
	Run Capacitor 40 MFD, 370 V	2	155 327 114	305 203 914
	Start Overload	1	275 411 119	305 215 919
	Run Overload	1	275 406 102	305 214 902
<b>7.5 hp - 6"</b> 282 201 9210	Relay - 230V*	1	155 031 601	305 213 961
	Start Capacitor 270-324 MFD, 330 V	1	275 468 119	305 208 919
	Start Capacitor 216-259 MFD, 330 V	1	275 468 118	305 208 918
	Run Capacitor 45 MFD, 370 V	1	155 327 109	305 203 909
	Start Overload	1	275 411 102	305 215 902
	Run Overload	1	275 406 122	305 214 922
	Relay - 230V*	1	155 031 601	305 213 961
<b>10 hp - 6"</b> 282 202 9230	Start Capacitor 270-324 MFD, 330 V	1	275 468 119	305 208 919
	Start Capacitor 130-154 MFD, 330 V	1	275 463 120	305 206 920
	Start Capacitor 216-259 MFD, 330 V	1	275 468 118	305 208 918
	Run Capacitor 35 MFD, 370 V	2	155 327 102	305 203 902
	Start Overload	1	275 406 103	305 214 903
	Run Overload	1	155 409 101	155 409 101
<b>208 V Relay *</b>	Relay - 230V*	1	155 031 601	305 213 961
	Lightning Arrestor	1	150 814 902	150 814 902
<b>208 V Relay *</b>	Relay 1.5-3 hp (replaces 155031102)	1	155 031 103	305 213 903
	Relay 5-15 hp (replaces 155031601)	1	155 031 602	305 213 904

### Standard Control Box Parts - 50 Hz

HP Voltage Model No.	Rating	No. Req.	Component Part No.	Kit Order No.
<b>1.5 hp - 220 V</b> 282 350 8110	Start Capacitor 105-126 MFD, 220 V	1	275 464 113	305 207 913
	Run Capacitor 10 MFD, 370 V	1	155 328 102	305 203 909
	Overload Assembly - Run	1	275 411 114	305 215 914
	Relay 220 V	1	155 031 112	305 213 912
<b>2 hp - 220 V</b> 282 351 8110	Start Capacitor 189-227 MFD, 220 V	1	275 468 115	305 208 915
	Run Capacitor 20 MFD, 370V	1	155 328 103	305 204 903
	Overload Assembly - Run	1	275 411 102	305 215 902
	Overload Assembly - Start	1	275 411 106	305 215 906
	Relay 220 V	1	155 031 112	305 213 912
<b>3 hp - 220 V</b> 282 352 8110	Start Capacitor 270-324 MFD, 220 V	1	275 468 119	305 208 919
	Run Capacitor 35 MFD, 370 V	1	155 327 102	305 203 902
	Overload Assembly - Run	1	275 406 107	305 214 907
	Overload Assembly - Start	1	275 411 107	305 215 907
<b>5 hp - 220 V</b> 282 253 9010	Relay 220 V	1	155 031 112	305 213 912
	Start Capacitor 189-227 MFD, 220 V	2	275 468 115	305 208 915
	Run Capacitor 30 MFD, 220 V	1	155 327 101	305 203 901
	Run Capacitor 45 MFD, 220 V	1	155 327 109	305 203 909
	Overload Assmblly - Run	1	275 406 102	305 214 902
	Overload Assembly - Start	1	275 411 102	305 215 902
	Relay 220 V	1	155 031 112	305 213 912

**NOTE:** Some Franklin motors, controls and parts are not stock items and may need to be special ordered.

\* For 208 V systems or where line voltage is between 200 V and 210 V a low voltage relay and larger cable are required:

- Use relay part number 155 031 103 in place of 155 031 102 on 1.5 through 3 hp applications.
- Use relay 115 031 602 for 5-15 hp applications.
- Use the next size larger cable than is specified in the 230 V table.
- Boost transformers are an alternative to special relay and cable.

# Submersible Motor Control Boxes

## Control Box Parts

### Deluxe Control Box Parts

HP Size Model No.	Rating	No. Req.	Component Part No.	Kit Order No.
<b>2 hp - 4"</b> 282 301 8310	Start Capacitor 105-126 MFD, 220 V	1	275 464 113	305 207 913
	Run Capacitor 20 MFD, 370 V	1	155 328 103	305 204 903
	Start Overload	1	275 411 117	305 215 917
	Run Overload	1	275 411 113	305 215 913
	Contactactor	1	155 325 102	305 226 901
	Relay - 230 V*	1	155 031 102	305 213 902
<b>3 hp - 4"</b> 282 302 8310	Start Capacitor 208-250 MFD, 220 V	1	275 463 111	305 206 911
	Run Capacitor 45 MFD, 370 V	1	155 327 109	305 203 909
	Start Overload	1	275 411 118	305 215 918
	Run Overload	1	275 411 115	305 215 915
	Contactactor	1	155 325 102	305 226 901
	Relay - 230 V*	1	155 031 102	305 213 902
<b>5 hp - 4" &amp; 6"</b> 282 113 9310	Start Capacitor 270-324 MFD, 330 V	1	275 468 119	305 208 919
	Run Capacitor 40 MFD, 370 V	2	155 327 114	305 203 914
	Start Overload	1	275 411 119	305 215 919
	Run Overload	1	275 406 102	305 214 902
	Contactactor	1	155 326 101	305 347 903
	Relay - 230 V*	1	155 031 601	305 213 961
<b>7.5 hp - 6"</b> 282 201 9310	Start Capacitor 270-324 MFD, 330 V	1	275 468 119	305 208 919
	Start Capacitor 216-259 MFD, 330 V	1	275 468 118	305 208 918
	Run Capacitor 45 MFD, 370 V	1	155 327 109	305 203 909
	Start Overload	1	275 411 102	305 215 902
	Run Overload	1	275 406 121	305 214 921
	Contactactor	1	155 326 102	305 347 902
	Relay - 230 V*	1	155 031 601	305 213 961
<b>10 hp - 6"</b> 282 202 9330	Start Capacitor 270-324 MFD, 330 V	1	275 468 119	305 208 919
	Start Capacitor 130-154 MFD, 330 V	1	275 463 120	305 206 920
	Start Capacitor 216-259 MFD, 330 V	1	275 468 118	305 208 918
	Run Capacitor 35 MFD, 370 V	2	155 327 102	305 203 902
	Start Overload	1	275 406 103	305 214 903
	Run Overload	1	155 409 101	155 409 101
	Contactactor	1	155 326 102	305 347 902
Relay - 230 V*	1	155 031 601	305 213 961	
<b>15 hp - 6"</b> 282 203 9330	Start Capacitor 270-324 MFD, 330 V	2	275 468 119	305 208 919
	Start Capacitor 161-193 MFD, 330 V	1	275 463 122	305 206 912
	Run Capacitor 45 MFD, 370 V	3	155 327 109	305 203 909
	Start Overload	1	275 406 103	305 214 903
	Run Overload	1	155 409 102	155 409 102
	Contactactor	1	155 429 101	305 347 901
	Relay - 230 V*	1	155 031 601	305 213 961
<b>15 hp - 6"</b> 282 203 9621 <b>X-Large Enclosure</b>	Start Capacitor 350-420 MFD, 330 V	2	275 468 120	305 208 920
	Run Capacitor 45 MFD, 370 V	3	155 327 109	305 203 909
	Start Overload	1	275 406 103	305 214 903
	Run Overload	1	155 409 102	155 409 102
	Contactactor	1	155 429 101	305 347 901
	Relay - 230 V*	2	155 031 601	305 213 961
<b>All</b>	Lightning Arrestor	1	150 814 902	150 814 902
<b>208 V Relay*</b>	Relay 1.5-3 hp (replaces 155 031 102)	1	155 031 103	305 213 903
	Relay 5-15 hp (replaces 155 031 601)	1	155 031 602	305 213 904

**NOTE:** Some Franklin motors, controls & parts are not stock items and may need to be special ordered.

\* For 208 V systems or where line voltage is between 200 V and 210 V a low voltage relay and larger cable are required:

- Use relay part number 155 031 103 in place of 155 031 102 on 1.5 through 3 hp applications.
- Use relay 115 031 602 for 5-15 hp applications.
- Use the next size larger cable than is specified in the 230 V table.
- Boost transformers are an alternative to special relay and cable.

# Single-Phase Motor Protection

## Single-Phase Protection Devices



### Applications

These protection devices are designed to protect Franklin Electric single-phase motors from the various conditions listed below.



QD Pumptec is designed to easily plug into any Franklin QD Relay Control Box.

	QD Pumptec	Pumptec IR	Pumptec-Plus
Air or Gas Locked Pump (Cavitation)	■	■	■
Broken Shaft or Coupling	■	■	■
Clogged Well Screen	■	■	■
Drop in Water Level	■	■	■
Faulty Check Valve		■	■
High Voltage	■	■	■
Low Voltage	■	■	■
Low Yield Wells	■	■	■
Rapid Cycling		■	■
Water Logged Tank		■	■
Worn Pump Parts	■	■	■

### QD Pumptec

Exclusively designed for Franklin QD Relay Control Boxes, QD Pumptec is a solid state sensing device that monitors motor load and incoming power to automatically shut off a Franklin single-phase, 3-wire motor when related fault conditions are detected. QD Pumptec easily plugs into 3-wire Franklin QD Control Boxes with no additional wiring or tools required.

### Pumptec IR

Pumptec is a microcomputer-based device that monitors motor load and power line conditions to provide protection against dry well conditions, waterlogged tanks, and abnormal line voltage conditions. Pumptec interrupts power to the motor whenever the load drops quickly or below a preset level. Indicator lights provide complete system status.

### Pumptec-Plus

The Pumptec-Plus solid state pump protection system is designed for 1/2 to 5 hp single-phase submersible pump motors. Pumptec-Plus protects against a variety of fault conditions. Run and fault lights make diagnosis quick and easy. Push button Snap Shot™ calibration makes Pumptec-Plus simple to install and an effective troubleshooting tool.

# Single-Phase Motor Protection

## Single-Phase Electronic Protection Device Specifications

PRODUCT	HP RANGE	KW RANGE	VOLTS	HZ	RESET TIME	AGENCY APPROVALS
Pumptec W/ IR Control	1/3 - 1.5	0.25 - 1.1	115/230	60/50	Adjustable (2-120 Minutes)	UL/cUL Listed
Pumptec-Plus	1/2 - 5.0	0.37 - 3.7	230	60	Adjustable (1-240 Minutes or Manual)	UL/cUL Listed
Pumptec-Plus	1/2 - 5.0	0.37 - 3.7	220	50	Adjustable (1-240 Minutes or Manual)	UL/cUL Listed
QD Pumptec	1/3 - 1.0	0.25 - 0.75	230	60	Adjustable (2-240 Minutes)	UL/cUL Listed

## Models

PRODUCT	DESCRIPTION				MODEL	STOCK STATUS
	PH	HP	VOLTS	HZ		
Pumptec W/ IR Control	1P	1/3 - 1.5	115/230	60/50	580 002 0600	YES
Pumptec-Plus	1P	1/2 - 5.0	230	60	580 006 0100	YES
	1P	1/2 - 5.0	220	50	580 006 0500	YES
QD Pumptec	1P	1/3 - 1.0	230	60	580 007 0600	YES

## Single-Phase Protection Devices

PRODUCT	SHIPPING WEIGHT		MOTOR CARTON SIZE (in inches)
	LBS	KG	
Pumptec W/ IR Control	3	1.3	5.25 x 8.875 x 3.25
Pumptec-Plus	7	3.1	8.25 x 11.25 x 6.25
QD Pumptec	<1	<0.05	4.25 x 2.375 x 2.25

QD Pumptec

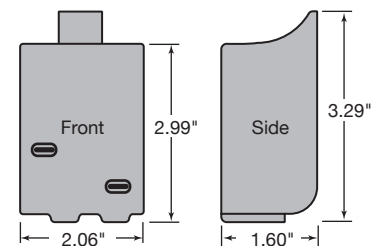

Pumptec IR

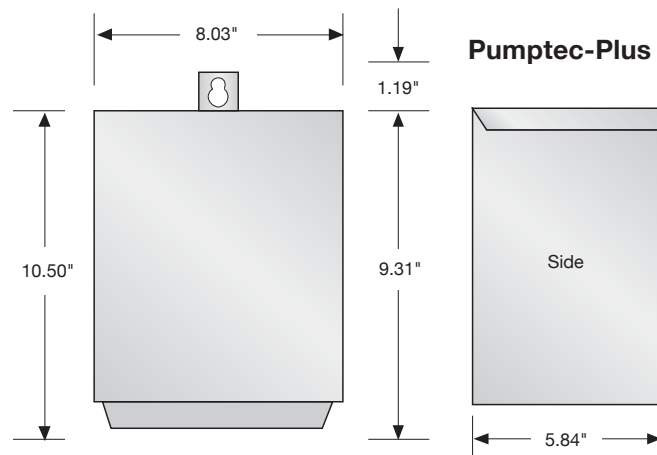
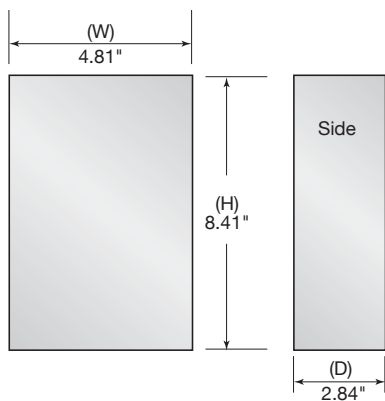

# Three-Phase Control Panels



## Applications

Franklin's heavy duty three-phase panels are optimized for water and irrigation applications. The spacious layout makes installation and maintenance simple and easy, so there's no need to spend time wrestling with wires, and adding components is easy. With a Franklin three-phase control panel, you can be sure that your system is set-up according to Franklin's recommendations.

Franklin Electric three-phase control panels are available from 3 to 200 hp, in ratings from 200 to 575 Volts.

## Basic Features

- UL approved, heavy-duty NEMA 3R enclosure
- Class R fusible disconnect
- Service entrance rated
- Lightning arrestor
- Motor logic or Franklin SubMonitor protected
- NEMA contactor
- Door wind hinge
- Pilot device and alarm terminal block
- H-O-A switch
- Manual push-to-start switch
- Easy hook-up

# Three-Phase Control Panels

## Models

HP	DESCRIPTION	VOLTS	HZ	AMPS	MODEL	WT
3 hp	MOTOR LOGIC	200	60	6-18	281 101 2203	56
		230	60	6-18	281 101 3303	56
		460	60	3-9	281 101 4402	56
		575	60	3-9	281 101 5502	56
	SUB-MONITOR	200	60	ALL	281 101 2200	59
		230	60	ALL	281 101 3300	59
460		60	ALL	281 101 4400	59	
575		60	ALL	281 101 5500	59	
5 hp	MOTOR LOGIC	200	60	9-27	281 101 2204	56
		230	60	9-27	281 104 3304	56
		460	60	3-9	281 101 4402	56
		575	60	3-9	281 101 5502	56
	SUB-MONITOR	200	60	ALL	281 101 2200	59
		230	60	ALL	281 101 3300	59
460		60	ALL	281 101 4400	59	
575		60	ALL	281 101 5500	59	
7.5 hp	MOTOR LOGIC	200	60	15-45	281 104 2206	60
		230	60	15-45	281 104 3306	60
		460	60	6-18	281 101 4403	56
		575	60	6-18	281 101 5503	56
	SUB-MONITOR	200	60	ALL	281 104 2200	63
		230	60	ALL	281 104 3300	63
460		60	ALL	281 101 4400	59	
575		60	ALL	281 101 5500	59	
10 hp	MOTOR LOGIC	200	60	15-45	281 104 2206	60
		230	60	15-45	281 104 3306	60
		460	60	9-27	281 101 4404	56
		575	60	6-18	281 101 5503	56
	SUB-MONITOR	200	60	ALL	281 104 2200	63
		230	60	ALL	281 104 3300	63
460		60	ALL	281 101 4400	59	
575		60	ALL	281 101 5500	59	
15 hp	MOTOR LOGIC	200	60	45-135	281 204 2208	147
		230	60	30-90	281 204 3308	145
		460	60	15-45	281 104 4406	60
		575	60	15-45	281 104 5506	60
	SUB-MONITOR	200	60	ALL	281 204 2200	150
		230	60	ALL	281 204 3300	148
460		60	ALL	281 103 4400	63	
575		60	ALL	281 104 5500	59	
20 hp	MOTOR LOGIC	200	60	30-90	281 205 2208	145
		230	60	30-90	281 205 3308	145
		460	60	15-45	281 104 4406	60
		575	60	15-45	281 104 5506	60
	SUB-MONITOR	200	60	ALL	281 205 2200	148
		230	60	ALL	281 205 3300	148
460		60	ALL	281 103 4400	63	
575		60	ALL	281 104 5500	59	

HP	DESCRIPTION	VOLTS	HZ	AMPS	MODEL	WT
25 hp	MOTOR LOGIC	200	60	30-90	281 206 2208	145
		230	60	30-90	281 206 3308	145
		460	60	15-45	281 104 4406	60
		575	60	15-45	281 104 5506	60
	SUB-MONITOR	200	60	ALL	281 206 2200	148
		230	60	ALL	281 206 3300	148
460		60	ALL	281 104 4400	63	
575		60	ALL	281 104 5500	63	
30 hp	MOTOR LOGIC	200	60	45-135	281 207 2209	147
		230	60	45-135	281 207 3309	147
		460	60	30-90	281 104 4407	145
		575	60	30-90	281 204 5507	145
	SUB-MONITOR	200	60	ALL	281 207 2200	151
		230	60	ALL	281 207 3300	151
460		60	ALL	281 106 4400	148	
575		60	ALL	281 204 5500	148	
40 hp	MOTOR LOGIC	460	60	30-90	281 205 4408	145
		575	60	30-90	281 204 5507	145
	SUB-MONITOR	460	60	ALL	281 205 4400	148
50 hp	MOTOR LOGIC	460	60	30-90	281 206 4408	145
		575	60	30-90	281 205 5508	145
	SUB-MONITOR	460	60	ALL	281 206 4400	148
60 hp	MOTOR LOGIC	460	60	45-135	281 207 4409	147
		575	60	45-135	281 307 5510	147
	SUB-MONITOR	460	60	ALL	281 207 4400	150
75 hp	MOTOR LOGIC	460	60	45-135	281 207 4409	147
		575	60	45-135	281 307 5510	147
	SUB-MONITOR	460	60	ALL	281 207 4400	150
100 hp	MOTOR LOGIC	460	60	90-270	281 308 4411	390
		575	60	45-135	281 307 5510	147
	SUB-MONITOR	460	60	ALL	281 308 4400	393
125 hp	MOTOR LOGIC	460	60	90-270	281 309 4411	390
		575	60	90-270	281 309 5511	390
	SUB-MONITOR	460	60	ALL	281 309 4400	393
150 hp	MOTOR LOGIC	460	60	90-270	281 310 4412	390
		575	60	90-270	281 309 5511	390
	SUB-MONITOR	460	60	ALL	281 310 4400	393
175 hp	MOTOR LOGIC	460	60	90-270	2813104412	390
		575	60	90-270	2813105512	390
	SUB-MONITOR	460	60	ALL	2813104400	393
200 hp	MOTOR LOGIC	460	60	18-540	2813114413	660
		575	60	90-270	2813105512	390
	SUB-MONITOR	460	60	ALL	2813114400	663
		575	60	ALL	2813105500	393

# Three-Phase Control Panels

## Three-Phase Control Panel Accessories



225 552 107

### Omega CN7500 Digital Reader for PT100 Sensor\*

The Omega CN7500 digital reader displays the temperature from Franklin Electric's PT100. The PT100 is a precision platinum wire resistor that is optional in Franklin's six- and eight-inch motors as a temperature input for process control equipment. The CN7500 digitally displays the temperature and can be set for certain temperature ranges. It trips the panel contactor in an over-temperature condition and resets the contactor once the temperature returns to the desired level.

See page 74 for PT100 sensor details

\* Due to space limitations, only auxiliary contacts and/or padlock attachments are available for NEMA 1 and 2 panels when a PT100 reader is selected.



### Control Circuit Transformers

Control circuit transformers convert the supply voltage required to power a piece of equipment to a voltage that is needed for various control circuits (pilot lights, selector switches, push buttons, etc.). The line voltage supplying the equipment is converted to control voltage by the transformer, eliminating the need to bring in a second source of power. (Note: Fuses are not supplied.)

PART #	NEMA SIZE	PRIMARY	SECONDARY	VOLT AMPS
225552131	1	240	120	100
225552141	1	480	120	100
225552132	2	240	120	100
225552142	2	480	120	100
225552133	3	240	120	150
225552143	3	480	120	150
225552134	4	240	120	300
225552144	4	480	120	300
225552135	5	240	120*	50
225552145	5	480	120*	50

#### NOTE:

For additional voltages, please specify both primary and secondary voltages.

\* Equipped with a NEMA rated AC control relay (open style) with two normally-open convertible instantaneous contacts (8501 XO20 Relay).

### Pilot Lights

Mounted on the enclosure door, the pilot light indicates when power is on/off or when a motor is in operation. It can easily be seen from the front of the panel. Choose your color to fit your application.

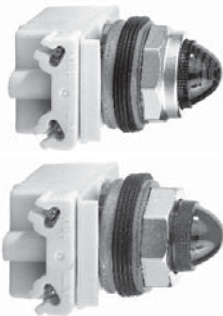

PART #	NEMA RATED	SIZE	LENS COLOR
225552101	Yes	30 mm	Red
225552102	Yes	30 mm	Green
225552103	Yes	30 mm	Amber
225552104	Yes	30 mm	Clear

## Three-Phase Control Panel Accessories — Cont.

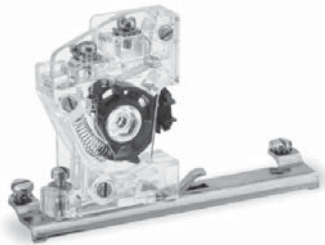

225 552 110

### Contacts

When adding control devices, auxiliary contacts may be required. These contacts mount on the side of the contactor and include one normally-open and one normally-closed auxiliary contact.



225 552 105

### Padlock Attachment for H-O-A Switch

The padlock attachment allows the owner to lock the hand-off auto switch in the “on” or “off” position to prevent tampering with the pump panel.



225 552 171

### Analog Style Elapsed Time Meter

The elapsed time meter keeps track of the total running time of the motor in hours. It is ideal for applications which require routine maintenance.



### SubMonitor

See page 68 for details



225 552 108

### cUL Rating

Panels can be equipped with the cUL rating to meet Canadian requirements.

# Three-Phase Motor Protection

## SubMonitor™ Three-Phase Protection



### Applications

SubMonitor is designed to protect three-phase pumps by monitoring current, voltage and motor temperature\* using three integrated current transformers. A face mounted digital display provides real-time current and voltage readings for all three legs and allows the user to set up the SubMonitor quickly and easily.

### Protects Against

- Under/Overload
- Under/Overtoltage
- Current Unbalance
- Overheated Motor (Subtrol-equipped)
- False Start (Chattering)
- Phase Reversal

### Features

- Quick, menu-driven set-up
- Digital display shows voltage and current on all three legs at once
- Fault messages in easily understandable text
- Rated for 190 to 600 volts
- No need for additional turns around the CT or to add external CTs
- Password protection option
- Din rail mounting option

- Stored fault, setting changes, and pump run-time information easily accessed through display head
- Detachable NEMA 3R display unit easily mounted on panel door
- Turn-and-push adjustment knob
- Base unit can operate independent of detachable head
- UL and cUL listed

### Three-Phase Electronic Protection Device Specifications

**Input Voltage** ..... 190 – 600 VAC  
**Frequency** ..... 60/50 Hz  
**Motor Service Factor Amps**..... 5 to 350 Amps  
**Maximum Conductor Size Through Sensors**  
 Max Diameter.....0.920 in. (23 mm)  
**Trip Response**  
 Motor Under/Overload, Under/Overtoltage,  
 Overheat, Unbalance .....3 seconds  
**Control Circuit Rating** ..... 1.5 Amp AC, up to 600 V

**Signal Circuit Rating**.....1 Amp AC, up to 250 V  
**Wiring Terminals**  
 Wire Gauge ..... #12 to #18 AWG  
 Tighten to ..... 4.5 in-lbs  
**Weight (SubMonitor)**.....3.3 lbs/1.5 kg  
**Carton Size (Std. Unit)**.....7.75 in x 11.5 in x 6.75 in  
 (19.7 cm x 29.2 cm x 17.1 cm)  
**Shipping Weight (Std. Unit)**..... 3.5 lbs/1.5 kg  
**Agency Approval** ..... UL and cUL listed

\* For motors equipped with a Subtrol heat sensor

# Three-Phase Motor Protection

## SubMonitor™ Three-Phase Protection

### Models

PRODUCT	DESCRIPTION				MODEL	STOCK STATUS
	PH	MAX AMPS RANGE	VOLTS	HZ		
SubMonitor Standard	3	5 - 350	190 - 600	60/50	586 000 5000	YES
SubMonitor Premium*	3	5 - 350	190 - 600	60/50	586 000 5100	YES

\* Includes lightning arrester and 3-year warranty on SubMonitor and Subtrol-equipped motor

### Dimensions and Weights

SHIPPING WEIGHT		MOTOR CARTON SIZE (in inches)
LBS	KG	
3.3	1.5	7.75 x 11.5 x 6.75

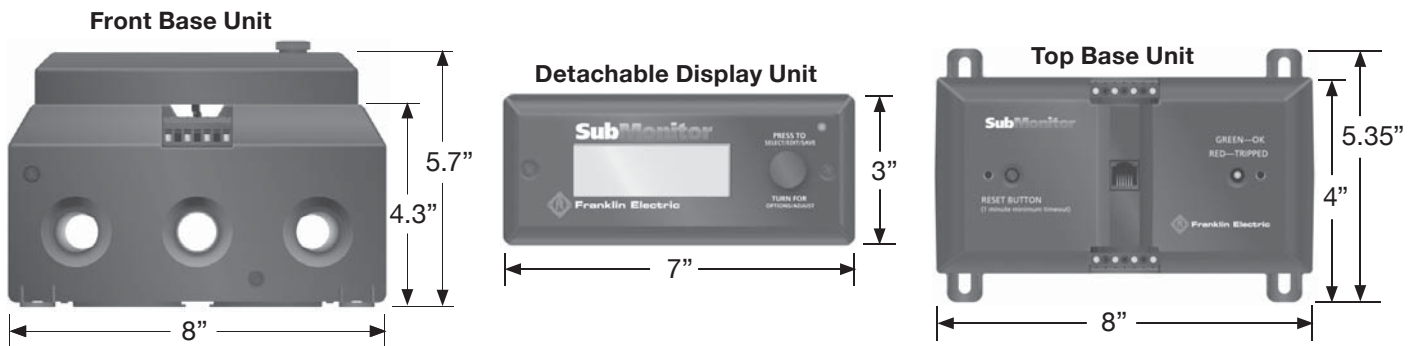

### Display

- Real-time display of voltage and current for each leg.
- Easy menu-driven setup and adjustment of monitoring parameters.

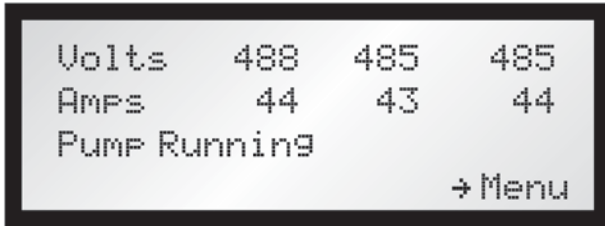

### SubMonitor Accessory



585 001 1100

#### D3 Data Download Tool

D3 is a service tool that provides the capability to download data from SubMonitor and transfer that data to a PC.

Includes:

- D3 unit
- Transfer software
- USB cable

# Constant Pressure Controllers



## Applications

Franklin Electric's constant pressure controllers use state-of-the-art technology to provide constant water pressure through variable speed control of submersible water well pumps.

## Features—All Controllers

- Constant water pressure with a wide range of settings (25 to 80 psi)
- NEMA 4 (Outdoor) and NEMA 1 (Indoor) Enclosures
- Easy installation
- Soft start feature prevents water hammer and increases motor life
- Works with small pressure tanks or existing larger tanks
- Smart Reset® technology allows well recovery before restarting the pump
- Single-phase input power with three-phase motor performance (SubDrive models)
- Excellent radio frequency interference shielding
- UL and cUL listed
- Built-in Diagnostics and Protection
  - Surge protection
  - Underload
  - Undervoltage
  - Locked pump
  - Open circuit
  - Short circuit
  - Overheated controller

# Constant Pressure Controllers

## Features — MonoDrive & MonoDriveXT

- Selectable hp rating: MonoDrive (½, ¾, and 1 hp), MonoDriveXT (1.5 and 2 hp)
- Easy installation – remove the 3-wire control box and install the MonoDrive
- Can retrofit existing systems – no need to pull the pump
- NEMA 4 & NEMA 1 enclosure
- Single-phase, 3-wire

## Features — SubDrive75, SubDrive100, SubDrive150 & SubDrive300

- Works with a standard three-phase Franklin Electric submersible motor
- NEMA 4 & NEMA 1 enclosure
- Three-phase performance with single-phase input
  - High starting torque
  - More efficient
  - Smooth running

## Constant Pressure Controls Specifications

		MonoDrive	MonoDriveXT	SubDrive75	SubDrive100	SubDrive150	SubDrive300
Model No. (Enclosure*)	(N1)	587 020 3110	587 020 4110	587 020 3380	587 020 4100	587 020 4150	N/A
	(N4)	587 020 3114	587 020 4114	587 020 3384	587 020 4104	587 020 4154	587 020 6300

### Input (From Power Source)

Voltage	190-260 V 1-Phase	190-260 V 1-Phase	190-260 V 1-Phase	190-260 V 1-Phase	190-260 V 1-Phase	190-260 V 1-Phase
Frequency	60/50 Hz	60/50 Hz	60/50 Hz	60/50 Hz	60/50 Hz	60/50 Hz
Max Amps (RMS)	5.7 A (½ hp), 8.7 A (¾ hp), 11 A (1 hp)	13 A (1.5 hp), 16 A (2 hp)	11 A	19 A	23 A	36 A
Power Factor	1 (Constant)	1 (Constant)	1 (Constant)	1 (Constant)	1 (Constant)	1 (Constant)

### Output (To Motor)

Voltage	Variable/1-Phase	Variable/1-Phase	Variable/3-Phase	Variable/3-Phase	Variable/3-Phase	Variable/3-Phase
Frequency	Variable (30-60 Hz)	Variable (30-60 Hz)	Variable (30-80 Hz)	Variable (30-80 Hz)	Variable (30-80 Hz)	Variable (30-80 Hz)
Max Amps (RMS)	4.0 A (½ hp), 6.6 A (¾ hp), 9.0 A (1 hp)	10 A (1.5 hp), 12 A (2 hp)	5.9 A	8.1 A	10.9 A	17.8 A

### For Use With:

Pump Rating	½, ¾ or 1 hp (Selectable)	1.5 or 2 hp (Selectable)	¾, 1 or 1.5 hp (Selectable)	1, 1.5 or 2 hp (Selectable)	1.5, 2 or 3 hp (Selectable)	3 or 5 hp (Selectable)
Motor Rating	½, ¾ or 1 hp, 230 VAC (1-Phase)	1.5 or 2 hp, 230 VAC (1-Phase)	1.5 hp, 230 VAC (3-Phase)	2 hp, 230 VAC (3-Phase)	3 hp, 230 VAC (3-Phase)	5 hp, 230 VAC (3-Phase)
Pressure Sensor (Included)	External	External	External	External	External	External
Controller Weight	(N1)	15.00 lbs (6.80 kg)	17.50 lbs (7.94 kg)	15.00 lbs (6.80 kg)	17.50 lbs (7.94 kg)	17.50 lbs (7.94 kg)
	(N4)	24.14 lbs (10.95 kg)	28.32 lbs (12.84 kg)	24.14 lbs (10.95 kg)	28.32 lbs (12.84 kg)	28.32 lbs (12.84 kg)
Carton Size (H x W x D)	(N1)	16½ x 12¾ x 9" 41.9 x 31.4 x 22.9 cm	16½ x 12¾ x 9" 41.9 x 31.4 x 22.9 cm	16½ x 12¾ x 9" 41.9 x 31.4 x 22.9 cm	16½ x 12¾ x 9" 41.9 x 31.4 x 22.9 cm	16½ x 12¾ x 9" 41.9 x 31.4 x 22.9 cm
	(N4)	17½ x 16¾ x 11¾" 44.5 x 41.6 x 28.9 cm	17½ x 16¾ x 11¾" 44.5 x 41.6 x 28.9 cm	17½ x 16¾ x 11¾" 44.5 x 41.6 x 28.9 cm	17½ x 16¾ x 11¾" 44.5 x 41.6 x 28.9 cm	17½ x 16¾ x 11¾" 44.5 x 41.6 x 28.9 cm
Shipping Weight	(N1)	19.23 lbs (8.72 kg)	21.28 lbs (9.65 kg)	19.23 lbs (8.72 kg)	21.28 lbs (9.65 kg)	21.28 lbs (9.65 kg)
	(N4)	30.91 lbs (14.02 kg)	35.09 lbs (15.92 kg)	30.91 lbs (14.02 kg)	35.09 lbs (15.92 kg)	35.09 lbs (15.92 kg)

\*N1 = NEMA 1 (Indoors), N4 = NEMA 4 (Outdoors)

# Constant Pressure Controllers

## SubDrive300

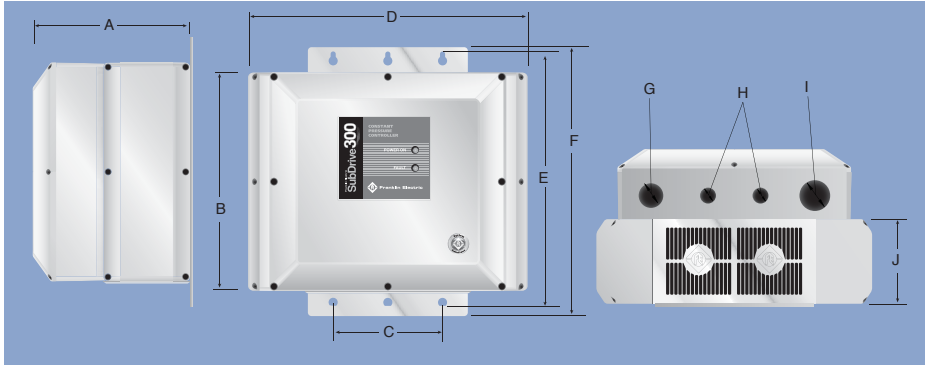

**NEMA 4 Dimensions in Inches** (approximate)

NEMA 4	A	B	C	D	E	F	G	H	I	J
Dimension	8.75	12	6	15.34	14	14.75	1.37	0.885	1.71	4.75
Conduit Size	-	-	-	-	-	-	1	½	1¼	-

## SubDrive75/100/150/MonoDrive/MonoDriveXT

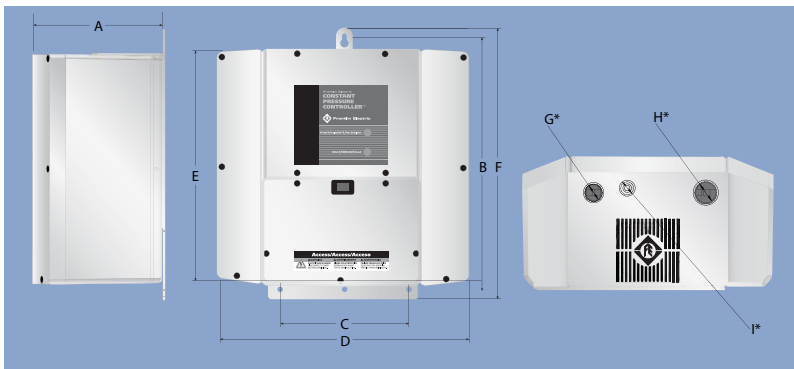

**NEMA 4 Dimensions in Inches** (approximate)

NEMA 4	A	B	C	D	E	F	G	H	I
Dimension	7.25	12.6	7	13.6	12.5	14.8	0.875/ 1.100	1.100/ 1.375	closed/ 0.473/ 0.875
Conduit Size	-	-	-	-	-	-	½ / ¾	¾ / 1	½

## SubDrive75/100/150/MonoDrive/MonoDriveXT

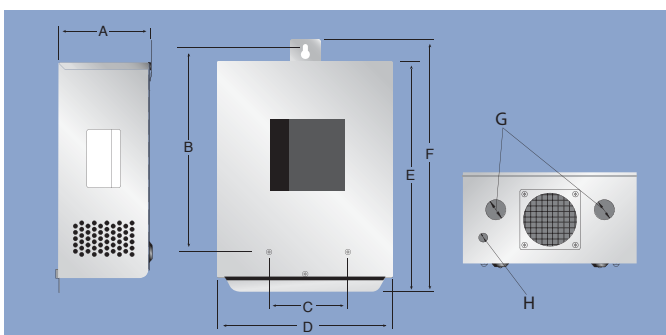

**NEMA 1 Dimensions in Inches** (approximate)

NEMA 4	A	B	C	D	E	F	G	H
Dimension	5.25	11.5	5.5	9.75	12.8	14	1.12	0.5
Conduit Size	-	-	-	-	-	-	¾	-

\* Use knock-outs as required.

## SubDrive Accessories



### SubDrive Duplex Alternator

The SubDrive Alternator allows a water system to alternate between two parallel pumps controlled by separate SubDrives or MonoDrives. The user-selected switching interval balances the run time of each pump system to evenly disperse the workload. In addition, when demand exceeds the capacity of one pumping system, the other system comes online to supplement production. The SubDrive Alternator can be used with any SubDrive or MonoDrive controller.

585 001 2000

<b>Input (From Power Source)</b>	Voltage	115 VAC
	Frequency	60 Hz
<b>Pressure Setting*</b>	Factory Preset	50 psi
	Adjustment Range	25-80 psi
<b>Approximate Controller Size (NEMA 4)</b>	Outer Dimensions	5.8 x 5.8 x 3.6" (14.7 x 14.7 x 9.1 cm)
	Weight	1.3 lbs (0.59 kg)

\* Pressure sensors must be set at least 3 psi apart.



### SubDrive/MonoDrive Fan Kits

Installers can remove the fan and make an attempt to clean the fan by removing any particles that may restrict movement. In applications where the fan cannot be cleaned or freed from particles, or is damaged or malfunctioning, the fan replacement kit is an easy and inexpensive fix.

#### NEMA 4

CONTROLLER	KIT PART NUMBER
MonoDrive SubDrive75	225 635 901
MonoDriveXT SubDrive100 SubDrive150	225 635 902
SubDrive300	External cooling fans 225 635 903
	Internal stirring fan 225 635 904

#### NEMA 1

CONTROLLER	DATE CODE	KIT PART NUMBER
SubDrive75 and MonoDrive	08L45 or prior	225 635 905
SubDrive75 and MonoDrive	After 08L45	225 635 908
SubDrive100/150 and MonoDriveXT	08K45 or prior	225 635 907
SubDrive100/150 and MonoDriveXT	After 08K45	225 635 909

# Submersible Motor Accessories

## Surge Arrestors

### Applications

These surge arrestors or their equivalents are highly recommended for protecting submersible motors from a variety of commonly occurring high voltage spikes which can damage the motor insulation system and cause motor winding failure. These arrestors will not, as is true of any surge protection equipment, protect the motor from a direct lightning strike.

MOTOR TYPE	NO. REQUIRED PER MOTOR	FRANKLIN PART NUMBER
Single-phase	1*	150 814 902
Three-phase	1**	155 440 902

#### NOTES:

\*Single-phase surge arrestor number 150 814 902 can be used on supply voltage systems up to 125 Volts to ground.

\*\*Three-phase surge arrestor number 155 440 902 can be used on supply voltage systems up to 650 Volts to ground.

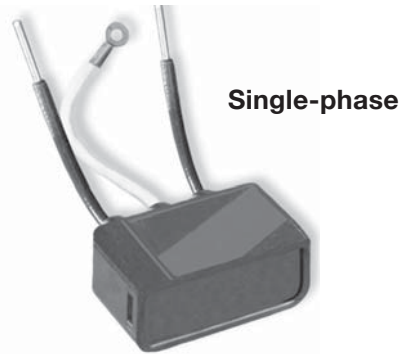

## PT100 Sensors

### Applications

The PT100 is a precision platinum wire resistor that is specified occasionally as a temperature input for process control equipment. A jacketed control lead must be run from the PT100 lead to the above-ground equipment. The above-ground equipment is not available from Franklin Electric and is typically part of a custom panel or data acquisition system.

PT100 sensor retrofit kits from Franklin Electric come with complete instructions and allow for easy field installation.

The PT100 is not approved as motor overload protection. Motor warranty will be void if agency approved motor overload protection is not installed as required by Franklin Electric's Application Installation Maintenance (AIM) Manual.



KIT NUMBER	FRANLIN PART NUMBER	FOR USE WITH MOTOR TYPES	INSULATION	LEAD INFORMATION			
				TEMPERATURE RATING	WIRE SIZE	LENGTH	
						FEET	METERS
305 327 901	165 608 901	6" (1/2 - 20 Threads)*	PVC	60 °C	AWG 20	29	8
305 327 903	165 608 903	6" (1/2 - 13 Threads)*	PVC	60 °C	AWG 20	29	8
305 326 902	165 624 902	8" (40 to 100 hp)	PVC	60 °C	AWG 20	29	8
305 326 901	165 624 901	8" (125 to 200 hp)	PVC	60 °C	AWG 20	29	8

#### NOTES:

\*6-inch motor PT100 selection:

Oct. 2001 and earlier date coded motors use the 1/2-20 thread PT100.

Nov. 2001 date coded motors have thread type verified for correct selection.

Dec. 2001 and later date coded motors use the 1/2-13 thread PT100.

# Submersible Motor Accessories

## Couplings

### Applications

Franklin Electric offers this line of motor-pump couplings for maximum customer convenience in matching the Franklin motor to a variety of pump shafts. Couplings are designed to transmit the pump thrust to the motor in order to provide maximum benefits from the Franklin internal thrust bearing construction.

Hardened stainless steel spacer discs in the 4" and 6" couplings assure positive bearing between motor and pump shafts, and assure full support for downward thrust created by the pump.

8" couplings DO NOT contain hardened spacer discs, since the motor shaft itself is hardened.

All couplings include Allen head 300 series stainless steel set screws.



### #416 Stainless Steel Couplings

MOTOR SIZE	PUMP SHAFT DIA.	STAINLESS STEEL KEY (INCLUDED) WxDxL	COUPLING PART NUMBER
4-Inch	3/4	3/16 x 1/8 x 1 3/8	151 551 911
6-Inch	3/4	3/16 x 1/8 x 1 3/4	151 935 902
6-Inch	7/8	1/4 x 3/16 x 1 3/4	151 935 901
6-Inch	1	1/4 x 3/16 x 1 3/4	151 935 909
8-Inch	1	1/4 x 1/4 x 2	151 922 901
8-Inch	1 3/16	1/4 x 1/4 x 2	151 922 906
8-Inch	1 3/16	5/16 x 5/16 x 2	151 922 902
8-Inch	1 1/4	5/16 x 5/16 x 2	151 922 903
8-Inch	1 1/2	3/8 x 3/8 x 2	151 922 904

### #316 Stainless Steel Couplings

MOTOR SIZE	PUMP SHAFT DIA.	STAINLESS STEEL KEY (INCLUDED) WxDxL	COUPLING PART NUMBER
4-Inch	3/4	3/16 x 1/8 x 1 3/8	151 551 931
6-Inch	3/4	3/16 x 1/8 x 1 3/4	151 935 922
6-Inch	7/8	1/4 x 3/16 x 1 3/4	151 935 921
6-Inch	1	1/4 x 3/16 x 1 3/4	151 935 929
8-Inch	1 3/16	1/4 x 1/4 x 2	151 922 926
8-Inch	1 1/4	5/16 x 5/16 x 2	151 922 923
8-Inch	1 1/2	3/8 x 3/8 x 2	151 922 924
8-Inch	1 11/16	3/8 x 3/8 x 2	151 922 929

#### NOTE:

316 SS couplings are normally used with corrosion-resistant motors.

# Submersible Motor Accessories

## 4-Inch Coupling

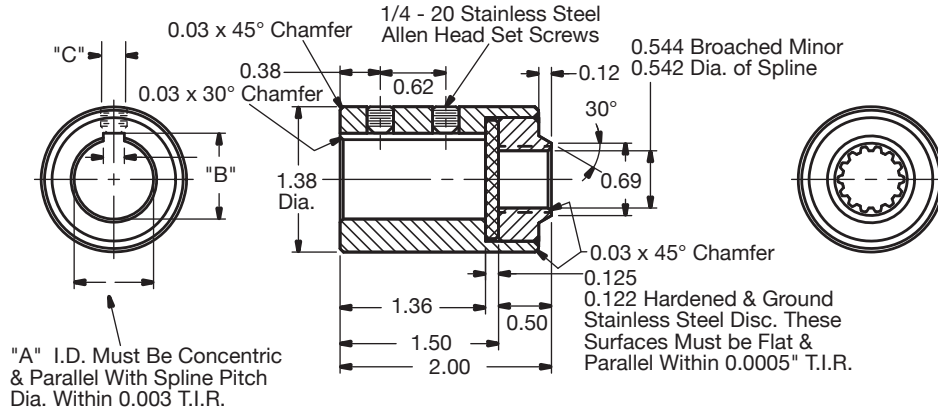

## 6-Inch Coupling

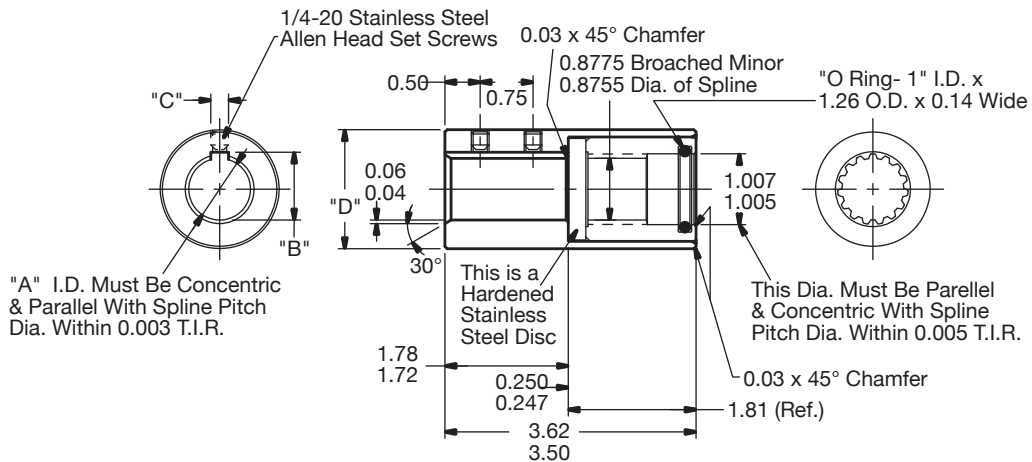

## 8-Inch Coupling

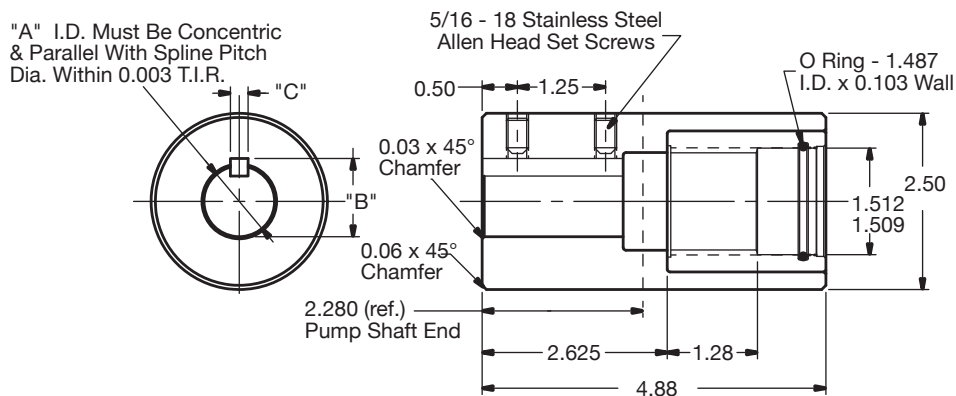

## QD Service Box

### Applications

Franklin Electric's QD service box is a service tool that provides capability to measure motor amps and line voltage with the motor running. The QD service box fits between the base and cover of an installed QD control box.

### Features

- Compatible with any Franklin Electric QD or CRC control box
- Meter jacks for measuring voltage while the motor is running
- Clamp-on ammeter access to all three motor leads for installations with jacketed cable or conduit
- Easy to use



Compatible With	Part Number
All QD & CRC Control Box Ratings	305 510 901

## Special Services

Special testing services are available for motors purchased from Franklin Electric. These services must be specified at time of order and will result in additional lead time.

### Performance Test - Calibrated Motor

- 1/3 - 3 hp, 4" Dia. motor
- 5 - 10 hp, 4" Dia. motor
- 5 - 60 hp, 6" Dia. motor
- 40-200 hp, 8" Dia. motor

### Submergence Performance Test

- 1/3 - 2 hp, 4" Dia. motor @ 1000 PSI (2-W 500 PSI)
- 3 - 10 hp, 4" Dia. motor @ 1000 PSI
- 5 - 30 hp, 6" Dia. motor @ 1000 PSI
- 40 - 60 hp, 6" Dia. motor @ 1000 PSI
- 8" Dia. motor @ 1000 PSI



**ATTENTION!**  
**IMPORTANT INFORMATION FOR INSTALLERS OF THIS EQUIPMENT!**

This equipment is intended for installation by technically qualified personnel. Failure to install it in compliance with national and local electrical codes, and within Franklin Electric recommendations, may result in electrical shock or fire hazard, unsatisfactory performance, and equipment failure. Franklin installation information is available from pump manufacturers and distributors, and directly from Franklin Electric. Call Franklin toll free 800-348-2420 for information.

**WARNING**

Serious or fatal electrical shock may result from failure to connect the motor, control enclosures, metal plumbing, and all other metal near the motor or cable, to the power supply ground terminal using wire no smaller than motor cable wires. To reduce risk of electrical shock, disconnect power before working on or around the water system. Do not use motor in swimming areas.

**ATTENTION!**  
**INFORMATIONS IMPORTANTES POUR L'INSTALLATEUR DE CET EQUIPEMENT.**

Cet équipement doit être installé par un technicien qualifié. Si l'installation n'est pas conforme aux lois nationales ou locales ainsi qu'aux recommandations de Franklin Electric, un choc électrique, le feu, une performance non acceptable, voire même le non-fonctionnement peuvent survenir. Un guide d'installation de Franklin Electric est disponible chez les fabricants de pompes, les distributeurs, ou directement chez Franklin. Pour de plus amples renseignements, appelez sans frais le 800-348-2420.

**AVERTISSEMENT**

Un choc électrique sérieux ou même mortel est possible, si l'on néglige de connecter le moteur, la plomberie métallique, boîtes de contrôle et tout métal proche du moteur à un câble allant vers une alimentation d'énergie avec borne de mise à la terre utilisant au moins le même calibre que les fils du moteur. Pour réduire le risque de choc électrique. Couper le courant avant de travailler près ou sur le système d'eau. Ne pas utiliser ce moteur dans une zone de baignade.

**ATENCION!**  
**INFORMACION PARA EL INSTALADOR DE ESTE EQUIPO.**

Para la instalación de este equipo, se requiere de personal técnico calificado. El no cumplir con las normas eléctricas nacionales y locales, así como con las recomendaciones de Franklin Electric durante su instalación, puede ocasionar, un choque eléctrico, peligro de un incendio, operación defectuosa e incluso la descompostura del equipo. Los manuales de instalación y puesta en marcha de los equipos, están disponibles con los distribuidores, fabricantes de bombas o directamente con Franklin Electric. Puede llamar gratuitamente para mayor información al teléfono 800-348-2420.

**ADVERTENCIA**

Puede ocurrir un choque eléctrico, serio o fatal debido a una errónea conexión del motor, de los tableros eléctricos, de la tubería, de cualquier otra parte metálica que está cerca del motor o por no utilizar un cable para tierra de calibre igual o mayor al de la alimentación. Para reducir el riesgo de choque eléctrico, desconectar la alimentación eléctrica antes de iniciar a trabajar en el sistema hidráulico. No utilizar este motor en albercas o áreas en donde se practique natación.

**TOLL FREE HELP FROM A FRIEND**

**1.800.348.2420**

**1.260.827.5102 (FAX)**



**Franklin Electric**

400 East Spring Street, Bluffton, Indiana 46714  
Tel: 260.824.2900 • Fax: 260.824.2909

[www.franklin-electric.com](http://www.franklin-electric.com)