

Motors for Hazardous Areas

D5 SERIES

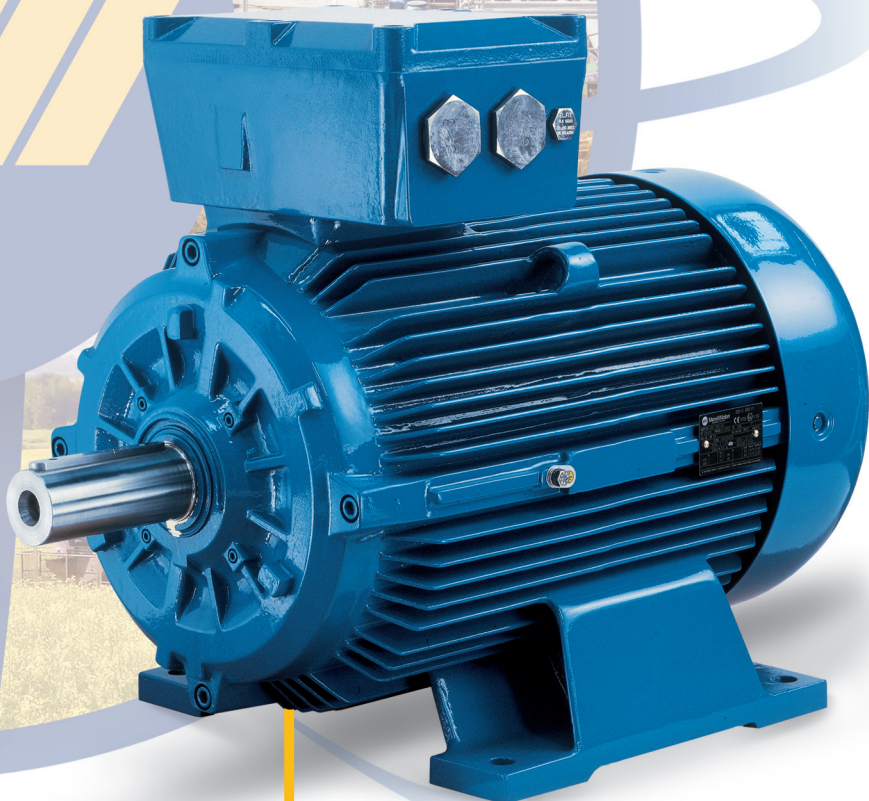

MarelliMotori

MarelliMotori is part of the FKI group of companies serving the world in the sectors of power generation, transmission and distribution. With over one hundred years of experience, MarelliMotori is a name synonymous with Quality and Manufacturing Excellence in the production of rotating machines.

MarelliMotori is recognised as a leading supplier to the Industrial, Petrochemical and Marine sectors, offering a complete range of standard and custom solutions for low and medium voltage motors and generators.



Our products are backed by an organisation of skilled people dedicated to providing the high standard of design, sales, service and technical support demanded by our customers. Our ability to offer flexible and rapid solutions is an integral part of achieving MarelliMotori's goal of Total Customer Satisfaction.

INDEX

Page

GENERAL ASPECTS OF THE ATEX DIRECTIVE	2
DEFINITIONS	3
MARKINGS	4
STANDARDS	5
NOMENCLATURE OF D5 SERIES MOTORS	5
EXAMPLES OF MARKINGS	6
PRODUCT CODE STRUCTURE	6
MOUNTINGS AND POSITIONS	7
MATERIALS	8
BALANCING AND VIBRATION GRADES	8
NOISE	8
BEARINGS	9
LUBRICATION INTERVALS	10
TERMINAL BOX AND CABLE ENTRANCE	10
PROTECTIVE TREATMENTS	11
THERMAL PROTECTIONS	11
GROUNDING	11
COUPLING	12
ANTICONDENSATION HEATERS	12
CONDENSATION DRAINAGE	12
CONNECTION DIAGRAMS	13
VOLTAGE AND FREQUENCY	14
OUTPUTS AND DERATINGS	15
EFFICIENCY AND POWER FACTOR	15
ELECTRICAL AND MECHANICAL TOLERANCES	16
STANDARD AND SPECIAL TESTS	16
MOTORS FED BY FREQUENCY CONVERTER	17
SELF-VENTILATED MOTORS	18
MOTORS WITH FORCED VENTILATION	18
TECHNICAL DATA – MAINS OPERATION – GROUP IIB – SINGLE SPEED	19
TECHNICAL DATA – FREQUENCY CONVERTER OPERATION	26
TECHNICAL DATA – MAINS OPERATION – GROUP IIB – DOUBLE SPEED	34
TECHNICAL DATA – MAINS OPERATION – GROUP IIC – SINGLE SPEED	37
TECHNICAL DATA – MAINS OPERATION – GROUP IIC – DOUBLE SPEED	38
DIMENSIONS 71 - 132	39
DIMENSIONS 160 - 315	43
DIMENSIONS 355 - 400	46

GENERAL ASPECTS OF THE ATEX DIRECTIVE

The directive 94/9/EC, better known as ATEX from the French term Atmosphères EXplosibles, is a European Community Directive, which defines the minimum health and safety requirements for apparatus intended for use in potentially dangerous environments. The directive is adopted by the European Union (EU) to facilitate free trade in the EU of products to which the Directive applies.

It conforms to the safety demands in essence by:

- The application of harmonised specific standards,
- The EC-type examination of products from a notified body, resulting in the appropriate certification,
- The manufacture of the product under a quality management system approved by a notified body.

In order to use electrical equipment in a potentially explosive atmosphere, such as combustible air – gas mixtures or combustible or conductive dust, the environment must first be classified in accordance with standard EN 60079-10 and with its related guide.

The classification, carried out by qualified competent professionals, identifying:

- the group of equipment,
- the category,
- the protection method,
- the temperature class, or the maximum surface temperature characteristics of the electrical motors to be used in this application.

DANGEROUS AREAS

The dangerous environments are classified into **zones**, shown in the following scheme:

Gas	Dust	Presence of potentially explosive atmosphere
Zone 0	Zone 20	Always present, frequent or lasting long periods during normal operation. The use of electric motors is not allowed.
Zone 1	Zone 21	Incidental presence: likely to occur during normal operation of the equipment.
Zone 2	Zone 22	Accidental presence: unlikely to occur during normal operation of the equipment.

GROUPS

The electrical apparatus is subdivided into two **groups** (EN 50014), according to the environments in which the equipment will operate.

Group	I	II
Environment	Used in subterranean mines and on the surface of mines in the presence of firedump and/or combustible dust.	Explosive atmospheres other than mines; surface industries.

CATEGORIES

Each group is classified into **categories**, according to the level of protection the apparatus must have:

Group I	Category	M1	M2
	Level of Protection	Very high	High
	In the presence of explosive atmosphere	The apparatus must remain operative	The electrical supply to the equipment must be interrupted

Group II	Category	1	2	3
	Level of Protection	Very high	High	Normal
	Presence of explosive atmosphere	High probability (always, often, for extended periods)	Probable	Low probability (rare and for a short time)
	Zones in which the equipment may be fed and may operate	0, 1, 2 and/or 20, 21, 22	only 1, 2 and/or 21, 22	only 2 and/or 22

The equipment belonging to group II is also specified by the **nature of the atmosphere** and can be arranged into the following categories:

G = mixture of air and gas, vapour or mist

D = mixture of air and combustible dust

Gas atmospheres are further divided into three sub – groups, according to the nature of the gas:

Group	Examples of some substances
II A	acetone, acetic acid, methanol, ethanol, benzene, ethane, methane, propane, toluene, xylene, combustible oil, kerosene, acetaldehyde, ethylbenzene, isoprene.
II B	coke-oven gas, ethylene, ethylene oxide, ethyl ether, formic aldehyde.
II C	hydrogen, acetylene, water gas, carbon sulphur.

A motor belonging to a particular group is also suitable for use in a lower group (e.g. a motor used in group IIB is also suitable for group IIA).

TYPES OF PROTECTION

The EN 60079-10 standard classifies the dangerous areas, while the standard EN 60079-14 defines the compatibility between the protection method with the aforementioned dangerous zones. The types of protection are defined as follows:

For mixtures of air and gas, vapour or fog	For mixtures of air and dust
“d” - Flameproof enclosures (EN 50018)	IP y5 + maximum permitted surface temperature (y=6 for category 2D; y=5 for category 3D). Electrical apparatus intended for use in environments with the presence of combustible dust. (EN 50281-1-1). When only this method of protection is requested, it is not necessary for the motors to be explosion proof, but in addition to the grade of protection mentioned above, they must have a maximum surface temperature limited to a specified value.
“e” - Increased safety (EN 50019)	
“n” - in accordance with standard EN 50021	

TEMPERATURE CLASS

See definition on page 4: “Maximum surface temperature”.

DEGREE OF PROTECTION IP56

Motors of Category 2G operating at a maximum ambient temperature of 40°C can be supplied on request with IP56 protection degree under the following temperature class:

- 2 pole motors: temperature class T3
- ≥ 4 pole motors: temperature class T3, T4

DEFINITIONS

The present catalogue lists motors for use in potentially explosive atmosphere, relative to:

- Group I - Category M2, for motor sizes 160-315;
- Group II - Category 2G, 2D.

EXPLOSIVE ATMOSPHERE

Is a mixture of flammable substances in the state of gas, vapour, mist and dust:

- with air,
- in which, after ignition, combustion spreads throughout the unconsumed mixture.

POTENTIALLY EXPLOSIVE ATMOSPHERE

It is an atmosphere which could become explosive either as a result of local and/or operating environmental conditions. The ATEX directive applies to products for use in this environment.

TYPE OF PROTECTION “d”

The electrical equipment has an enclosure suitable to:

- resist the internal pressure arising from the ignition of an explosive mixture within the equipment.
- avoid the transmission of the explosion to the external atmosphere in which the equipment is being used.
- ensure that the maximum external surface temperature is maintained within the limits specified by the temperature class of the equipment.

TYPE OF PROTECTION – INCREASED SAFETY “e”

A type of protection in which additional measures are applied so as to give increased security against the possibility of

- excessive temperature,
- the occurrence of arcs and sparks both inside and on external parts of electrical apparatus which does not produce arcs or sparks in normal service.

COMBINED TYPE OF PROTECTION “de”

Combines the essential requirements of protection types “d” and “e” (in accordance with standards EN 50018 and EN 50019) specifically:

- motor enclosures with protection “d” (in accordance with standard EN50018);
- terminal boxes with increased safety “e” (in accordance with standard EN 50019).

COMBINED CATEGORY 2G/2D

Combines the essential safety requirements:

- of protection type “d” (in accordance with standard EN50018),
- of the protection mode for electrical apparatus intended for use in environments with the presence of combustible dust, protection degree IP65 (EN50281-1-1).

MAXIMUM SURFACE TEMPERATURE

It is the maximum operating temperature reached in the most unfavourable conditions (but within relative limits) on the surface of the electrical apparatus. For equipment of group I, the maximum surface temperature must not exceed 150°C.

The following table is relevant to apparatus of category 2G, which is based on a predetermined temperature classification:

Temperature class	T1	T2	T3	T4	T5	T6
Maximum Surface Temperature (°C)	450	300	200	135	100	85

The maximum surface temperature is:

- the temperature of the external surfaces, for motors with protection mode “d”,
- the temperature of the external surfaces and of the internal points of the terminal box, for motors with protection mode “de”

In a potentially explosive atmosphere, the maximum surface temperature of the equipment must remain lower than the lowest possible spontaneous ignition temperature of the atmosphere surrounding it.

Electrical apparatus of category 2D are classified based on maximum surface temperature. This catalogue applies to motors having either of the following three maximum surface temperatures: T 150°C, T 135°C and T 100°C. In the case of atmospheres with combustible dust, the maximum permitted surface temperature depends on: the type of dust, the thickness of the layer of dust and on a safety factor used according to (EN 50281-1-2).

Motors of category 2G can also be used in installations requiring apparatus in category 3G, provided that they comply with the specified temperature class. Likewise, category 2D motors can be used in category 3D installations requiring the same or a higher maximum surface temperature.

MARKINGS

According to the 94/4/EC Directive, motors come with 3 markings giving the indispensable indications to safely use the product. These indications let the user check the compatibility between the protection mode of the motor and the classification of the area of its installation.

The data shown on the nameplate must therefore contain, in addition to the functional information, the 3 markings described below in sequence (CE, specific and supplementary) and the reference to the notified body in charge of the certification.

CE MARKING

The CE marking indicates that the D5 series motor conforms to all the applicable directives (and specifically to the ATEX directive).

It is a declaration of the manufacturer that the product conforms to the applicable directives and that the product conforms to the prototype on the basis of the quality check procedures it was submitted to.

The conformity procedure for the apparatus with respect to categories M2 and 2 demands for:

- EC-type examination released by a notified body (that issues the relative certification);
- product quality assurance (the product must be manufactured under a quality system which was valued and approved by a notified body).

MARKING SPECIFIC TO THE PROTECTION FROM EXPLOSIONS

In accordance with the 94/4/EC directive and EN 50014 standard, the apparatus must be supplied with the markings specific to protection from explosions:

Symbol  + GROUP (I or II) + CATEGORY (M2 or 2) + (only for group II) letter G (Gas) and/or D (dust)

SUPPLEMENTARY MARKING

The supplementary marking, in accordance with the 94/4/EC directive and to the EN 50014 standard, uses the following symbols:

EEx	indicating that the product conforms to one or more protection types, subject to the specific European standards;
d, e,	type of protection;
I, II,	equipment group with sub-group of gas for group II
T3,	temperature class (for category 2G) or maximum surface temperature (for category 2D).
IP65	protection degree of the motor enclosure for category 2D.
T xxx°C	maximum surface temperature for motors of category 2D and 3D.

STANDARDS

Standards relevant to electrical apparatus for potentially explosive atmospheres

Title	Standard
General requirements	EN 50014
Flameproof enclosure "d"	EN 50018
Increased safety "e"	EN 50019
Electrical apparatus for use in the presence of combustible dust – Electrical apparatus protected by enclosures – Construction and testing	EN 50281-1-1

General standards for electric motors

Title	Standard
Rating and Performance	EN 60034-1 (*)
Methods for determining losses and efficiency	EN 60034-2 (*)
Classification of degrees of protection (IP code)	EN 60034-5 (*)
Methods of cooling (IC code)	EN 60034-6 (*)
Classification of type of construction and mounting arrangement (IM code)	EN 60034-7 (*)
Terminal markings and direction of rotation	EN 60034-8 (*)
Noise limits	EN 60034-9 (*)
Built-in thermal protections	IEC 60034-11
Starting performance of rotating electrical machines	EN 60034-12 (*)
Mechanical vibration	EN 60034-14 (*)
Standard Voltages	IEC 38
Dimensions and outputs for electrical machines	EN 60072-1 (*)
General purpose three-phase induction motors having standard dimensions and outputs	EN 50347

(*) Exist as IEC standards.

NOMENCLATURE OF THE D5 SERIES MOTORS

The D5 series motors are divided into the following types:

Series ⁽¹⁾	Specific Marking			Supplementary Marking			Polarity		Supply		Frame size where applicable
	Ex	Group	Category	Protection	Group	Temperature Class (Maximum surface temperature)	single	doublet	mains	inverter	
D5C		II	2G	EEx d	II B	T3, T4, T5	X		X		71 - 400
D5D ⁽³⁾								X	X		
D5X		II	2G	EEx de	II B	T3, T4, T5	X		X		71 - 400
D5E ⁽³⁾								X	X		
D5F		II	2G	EEx d	II B	T3, T4	X			X	71 - 400
D5S				EEx de			X			X	
D5K		II	2G	EEx d	II C	T3, T4	X		X		160 - 315
D5Y								X	X		
D5R		II	2G	EEx d	II C	T3, T4	X			X	160 - 315
D5V				EEx de			X			X	
D5T		I	M2	EEx d,	I		X		X	⁽⁴⁾	160 - 315
D5U				EEx de				X	X		
D5A		II	2D	IP 65		(T 150°C) (T 135°C) (T 100°C)	X		X	⁽²⁾	71 - 400
D5B ⁽³⁾								X	X		

1: Series name of combined category 2G/2D motors = Series name of category 2G motors.

2: The D5A motors can be supplied on request for frequency converter application with maximum surface temperature of T135°C or T150°C.

3: Motors available with Temperature Class T3 (D5D, D5E) and Maximum Surface Temperature T150°C (D5B).

4: The D5T motors can be supplied on request for frequency converter application with temperature Class T3.

EXAMPLES OF MARKINGS

The following indicates some examples of markings for D5 series motors

D5X series.

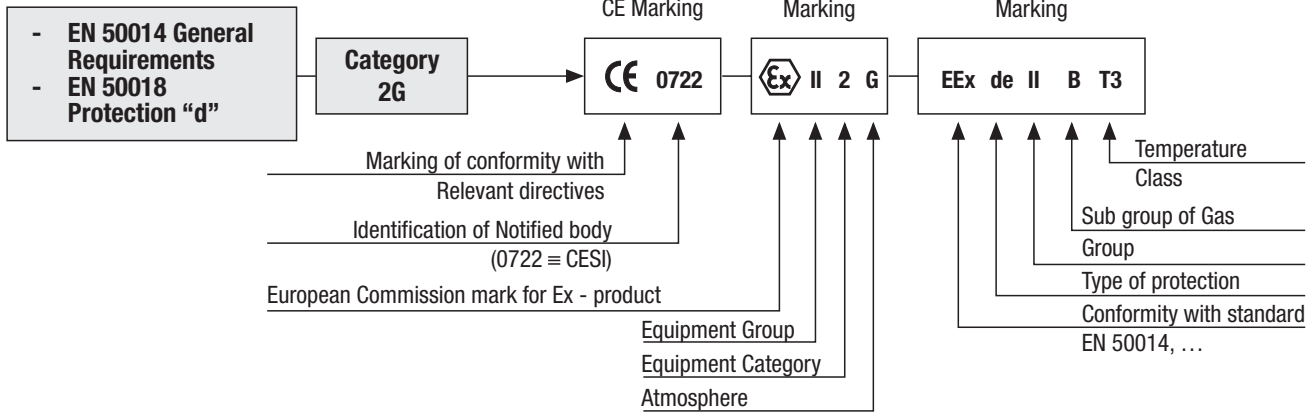

D5X series.

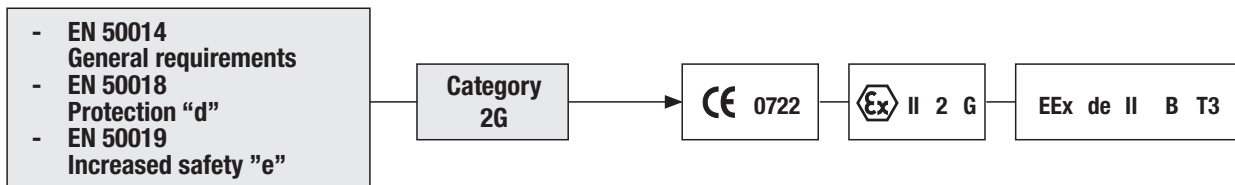

D5T and D5U series.

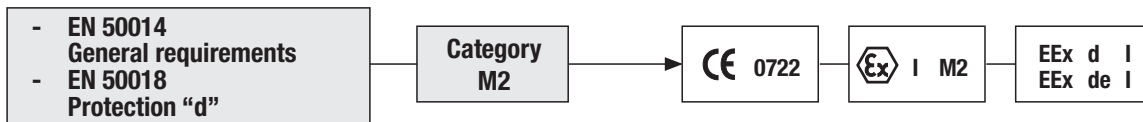

D5A and D5B series.

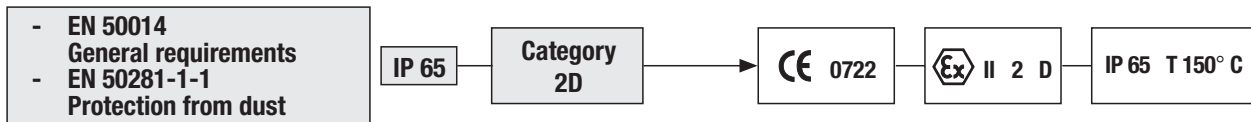

D5C series - Combined category

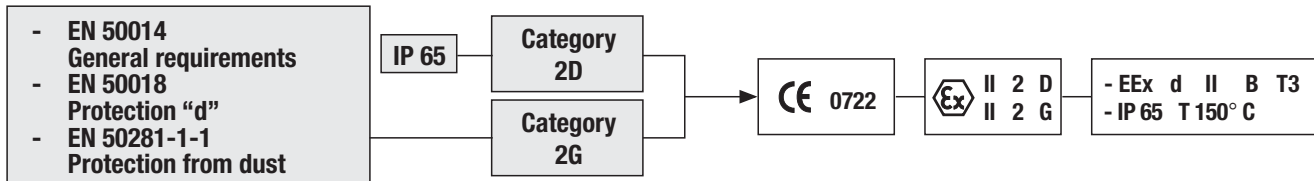

PRODUCT CODE STRUCTURE

MarelliMotori products are identified by 13 digit code show on the nameplate. The code is constructed as follows.

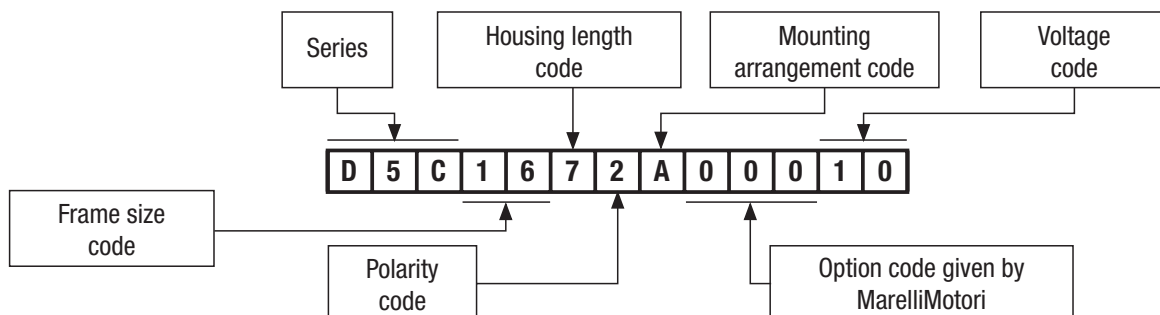

MOUNTINGS AND POSITIONS

Motors are supplied according to type of construction B3, B5, B3B5, B14, B3B14 and V1 compatible with the mounting arrangements shown in table below as defined in IEC 60034-7. Nameplates are marked with the abovementioned type of construction.

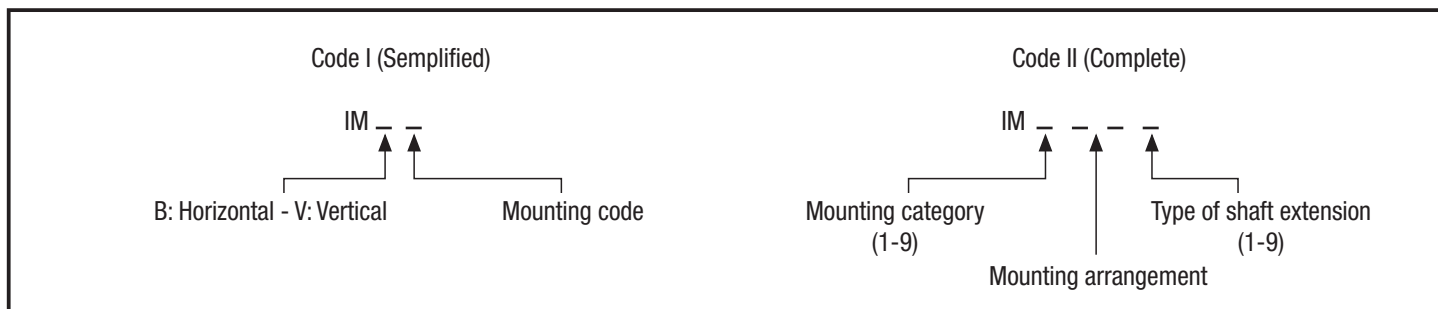

Code I	Code II		71 - 112	132	160 - 250	280 - 315	355 - 400
IM B3	IM 1001	 1)	●	●	●	●	●
IM B35	IM 2001	 1) 2)	●	●	●	●	●
IM B34	IM 2101	 1) 3)	●				
IM B5	IM 3001	 2)	●	●	●	X	
IM B6	IM 1051	 1)	●	●	●	X	
IM B7	IM 1061	 1)	●	●	●	X	
IM B8	IM 1071	 1)	●	●	●	X	
IM B14	IM 3601	 3)	●				

Code I	Code II		71 - 112	132	160 - 250	280 - 315	355 - 400
IM V1	IM 3011	 2)	●	●	●	●	●
IM V15	IM 2011	 1) 2)	●	●	●	●	●
IM V3	IM 3031	 2)	●	●	●	X	
IM V36	IM2031	 1) 2)	●	●	●	X	
IM V5	IM 1011	 1)	●	●	●	X	
IM V6	IM 1031	 1)	●	●	●	X	
IM V18	IM 3611	 3)	●				
IM V19	IM 3631	 3)	●				

- 1) Motors with feet
- 2) Flanged motors: unthreaded through holes
- 3) Flanged motors: threaded dead holes
- Standard
- X Consults MarelliMotori

Motors from frame size 71 and above are supplied with lifting eye bolts displaced according to type of construction B3 whereas they will be displaced according to type of construction V1 only if provided with antirain canopy.

MATERIALS

The mechanical components used in D5 series motors are made of the materials shown in the table below:

Components	Size					
	71 - 132	160 - 280	315		355 - 400	
			2 - 6 poles	≥ 8 poles	2 - 4 poles	≥ 6 poles
Frame	Cast Iron	Cast Iron (*)			Steel	
Endshields						
Fan cowl	Aluminium Alloy	Steel				
Fan	Thermoplastic (**)			Metal		
Terminal Box	Cast Iron			Steel		

(*) Steel for EEx d IIC motors.

(**) Metal is used for motors of M2 category.

BALANCING AND VIBRATION GRADES

The motors are dynamically balanced with a half key applied to the shaft extension in accordance with standard EN 60034-14 to vibration grade normal (N) in standard configuration.

Larger vibrations may occur on motors installed at site, due to various factors such as unsuitable foundations or resonance with the driven system. In such cases additional checks should also be carried out on each element of the installation.

Motors can be supplied with reduced (R) or special (S) vibration level on request.

The following table indicates the maximum vibration limits with respect to the different shaft heights

Vibration grade	Rated speed (min ⁻¹)	Maximum rms value of vibration speed for shaft height H in mm. [mm/s].		
		71 ≤ H ≤ 132	132 < H ≤ 225	250 < H ≤ 400
N normal	600 - 3600	1,8	2,8	3,5
	600 - 1800	0,71	1,12	1,8
R reduced	> 1800 - 3600	1,12	1,8	2,8
	600 - 1800	0,45	0,71	1,12
S special	> 1800 - 3600	0,71	1,12	1,8
	600 - 1800	0,45	0,71	1,12

The instrumentation can have a measurement tolerance of ±10%.

NOISE

The following table shows the medium values of A-sound pressure level (LpA) for group IIB motors, measured at a one-metre distance according to standard ISO R 1680. The sound levels are measured with the motor running at 50 Hz, in no-load conditions and have a tolerance of 3 dB(A). At 60 Hz the values of sound pressure increase by approximately 4 dB(A).

Frame size	A-sound pressure level (LpA) [dB(A)]			
	2 poles	4 poles	6 poles	8 poles
	LpA	LpA	LpA	LpA
71	60	53	-	-
80	67	53	53	53
90	73	53	56	56
100	77	61	61	61
112	76	58	58	58
132	78	66	62	60
160	78	65	62	61
180 M	78	65	-	-
180 L	-	69	63	62
200	80	69	63	62
225	84	74	66	63
250	84	74	66	63
280	84	77	72	72
315 SM	83	78	74	74
315 M	83	78	74	74
355	82	79	75	70
400	82	81	76	73

BEARINGS

The theoretical lifetime of bearings, L10h according to ISO 281/1 standard, of standard horizontal construction motors, without external forces (radial and/or axial) is in excess of 50,000 hours.

The lifetime of bearings is determined by multiple factors and specifically by:

- the external loads and level of vibration
- the lifetime of the grease (mainly on double screen bearings),
- the environmental conditions and working temperature.

Motors with frame sizes from 71 to 132 in standard configuration have double screen prelubricated ball bearings.

The correspondent grease life under normal operating conditions for a motor with horizontal shaft, running at 50 Hz and at maximum ambient temperature of 40°C is:

- 10,000 hours in continuous duty for 2 pole motors,
- 20,000 hours in continuous duty for 4 pole motors.

The axial positioning of the rotor is carried out by means of a preload washer at the N-end, as shown in the diagram to the right.

The following table describes the bearing types used on the different frame sizes.

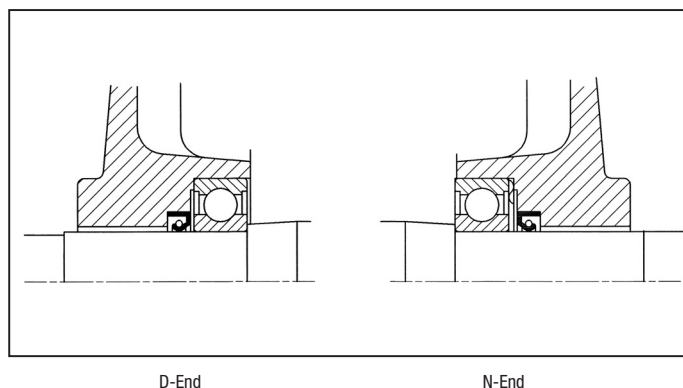

Frame Size	D-End (*)	N-End (*)
71	6202-2Z	6202-2Z
80	6204-2Z	6204-2Z
90	6205-2Z	6205-2Z
100	6206-2Z	6206-2Z
112	6206-2Z	6206-2Z
132	6308-2Z	6308-2Z

(*) Different types can be supplied on D5A and D5B series motors.

Category 2G group IIB motors from 160 to 315 frame size in standard configuration are equipped with:

- single screen prelubricated ball bearings (160 - 250 without regreasing system; 280 - 315 with regreasing system) for group IIB; 160 - 250 frame motors can be supplied with regreasing system and the relative grease exhausts on request. The N-end bearing is axially preloaded by means of a preload washer.
- D-end roller bearing (except for 2 pole motors) and N-end ball bearing for group IIC motors.

Frame Size	Group I M2 and IIB				Group IIC			
	D-End (*)		N-End (*)		D-End (*)		N-End (*)	
	Horizontal	Vertical	Horizontal	Vertical	Horizontal	Vertical	Horizontal	Vertical
160-180M	6310-Z-C3		6209-Z-C3		NU 210 E-C3		6209-2Z-C3	
180 L	6310-Z-C3		6210-Z-C3		NU 210 E-C3		6210-2Z-C3	
200	6312-Z-C3		6210-Z-C3		NU 212 E-C3		6210-2Z-C3	
225	6313-Z-C3		6213-Z-C3		NU 213 E-C3		6213-2Z-C3	
250	6314-Z-C3		6213-Z-C3		NU 214 E-C3		6213-2Z-C3	
280 - 2 poles	6314-Z-C3		6314-Z-C3		6314-C3		6314 C3	
280 ≥ 4 poles	NU2217-EC-C3		6314-Z-C3		NU2217-EC-C3		6314-C3	
315 - 2 poles	6316-C3		6316-C3		6316-C3		6316-C3	
315 ≥ 4 poles	NU2219-EC-C3		6316-C3		NU2219-EC-C3		6316-C3	

(*) Different types can be fitted with series D5A and D5B motors.

Motors from 355 to 400 frame size in standard configuration are equipped with regreasable rolling bearings.

The supports are equipped with grease nipples. In standard configuration, the rotor is axially fixed on the N-End side.

MOUNTING ARRANGEMENT B3 - IM1001

Frame Size	Poles	D-End	N-End
355 ÷ 400	2	6217 - C3	6217 - C3
355	≥ 4	NU 222 - C3	6217 - C3
400	≥ 4	NU 222 - C3	6222 - C3

MOUNTING ARRANGEMENT V1 - IM3011

Frame Size	Poles	D-End	N-End
355 ÷ 400	2	6217 - C3	7217 B
355	≥ 4	NU 222 - C3	6217 - C3 + 7217 B
400	≥ 4	NU 222 - C3	6222 - C3 + 7222 B

For different bearing configurations contact MarelliMotori.

LUBRICATION INTERVALS

The following table indicates the lubrication intervals of motors without regreasing system in standard configuration and the relubrication intervals of motors with regreasing system in standard configuration.

The shown values refer to normal operating conditions at a maximum ambient temperature of 40°C.

Motors without regreasing system - Group IIB

Frame Size	Lubrication Interval (H)							
	3600 min ⁻¹	3000 min ⁻¹	1800 min ⁻¹	1500 min ⁻¹	1200 min ⁻¹	1000 min ⁻¹	900 min ⁻¹	750 min ⁻¹
160 - 180	7000	7500	12000	14000	16000	18000	21000	26000
200	5500	7000	11000	12000	14000	16000	18000	23000
225	5500	7000	10000	11000	14000	16000	18000	22000
250	5000	5500	9500	11000	13000	14000	17000	20000

Motors with regreasing system - Group IIB

Frame Size	Relubrication Interval (H)							
	3600 min ⁻¹	3000 min ⁻¹	1800 min ⁻¹	1500 min ⁻¹	1200 min ⁻¹	1000 min ⁻¹	900 min ⁻¹	750 min ⁻¹
280	3200	4000	2000	2200	2800	3400	3800	4600
315	2800	3400	1700	2000	2600	3000	3400	4200
355 - 400 (B3)	3400	4000	1500	1800	2200	2800	3000	3600
355 - 400 (V1)	2000	2200	1500	1800	2200	2800	3000	3600

Motors with regreasing system - Group IIC

Frame Size	Relubrication Interval (H)							
	3600 min ⁻¹	3000 min ⁻¹	1800 min ⁻¹	1500 min ⁻¹	1200 min ⁻¹	1000 min ⁻¹	900 min ⁻¹	750 min ⁻¹
160 - 180	1700	2000	3400	4000	5000	6000	6500	8000
200	1400	1700	2800	3200	4200	5000	5500	6600
225	1300	1500	2600	3000	3800	4500	5000	6000
250	1200	1500	2400	2800	3600	4400	4500	5500
280	3200	4000	2000	2200	2800	3400	3800	4600
315	2800	3400	1700	2000	2600	3000	3400	4200

TERMINAL BOX AND CABLE ENTRANCE

Motors from 71 to 132 frame size have main terminal box on the right side (when seen from D-end, B3 mounting) and are normally equipped with 6 terminals. The terminal box can be rotated in steps of 90°.

Frame Size	Type of terminal	Terminal thread	Cable entrance holes
71 ÷ 90	Threaded terminals	M6	M25 x 1,5
100 ÷ 132	Threaded terminals	M6	M32 x 1,5

Motors from 160 to 400 frame size have the main terminal box on top (B3 mounting) and are normally equipped with 6 terminals. The terminal box can be rotated in steps of 90°.

Frame Size	Type of terminal	Terminal thread	Cable entrance holes
160 - 200	Threaded terminals	M6	M40x1,5 + M40x1,5 ⁽¹⁾
225 - 250	Threaded terminals	M8	M50x1,5 + M50x1,5 ⁽¹⁾ + M20x1,5 ⁽¹⁾
280 - 315	Threaded terminals	M12	M75x1,5 + M75x1,5 ⁽¹⁾ + M20x1,5 ⁽¹⁾
355 - 400	Threaded terminals	M20	M75x1,5 + M75x1,5

(1) Closed with a certified plug, in accordance with Directive 94/4/EC, when not used.

PROTECTIVE TREATMENTS

EXTERNAL SURFACES

The **standard painting process** consists of the application of epoxy-vinyl/polyurethane paint: the surface treatment, material and paint thickness make D5 series motors suitable for use in standard industrial environments.

A **special painting process**, consisting of epoxy-vinyl paint followed by polyacrilic paint is available on request. This process is particularly recommended for:

- aggressive environments;
- outdoor installations where salt is present or environments with the presence of anhydric gases;
- marine installations;

The standard finishing colour is RAL 5010. Other RAL and MUNSSELL colours are available on request.

Description	Process	Characteristics	Thickness
Painting	Standard	Two-component paint formulated with solid epoxy resins modified with vinyl polyamide catalysers	≥ 50 μm
	On request	Std + additional polyacrilic coat formulated with an aromatic semialiphatic catalyser	≥ 200 μm
Finishing paint	Standard	RAL 5010	
	On request	RAL & MUNSSELL colours	

INTERNAL SURFACES

The internal parts of the motors are treated with an insulating enamel to prevent motor corrosion due to humidity and aggressive substances. Such treatment added to the impregnation of active parts is an essential requirement for motors intended for use in industrial, tropical-humid environments.

THERMAL PROTECTIONS

The motors must be protected against overload by setting the omnipolar timer to time inversion (EN 60079-14) (timer not scope of MarelliMotori supply). The motors can however be equipped with additional thermal protections which characteristics are given in the following table.

Additional built-in thermal protections		
Type	Operating principle	Frame sizes where applicable
Bimetallic devices	Motoprotectors with contacts Normally Closed. The disc opens when the winding temperature reaches limits dangerous to the insulation system of the motor.	90÷400
(Positive Temperature Coefficient) Thermistors PTC	At the active temperature this device quickly changes its resistance value.	90÷400
Platinum resistance thermometers PT100	Variable linear resistance with the winding temperature, particularly suitable for a continuous winding temperature monitoring.	160÷400

The intervention temperature of the thermal protection to be selected is dependent on the temperature class and/or on the allowed maximum surface temperature. D5 series motors from frame size 160 and above in standard configuration have 3 PTC with terminals in the main terminal box.

All motors for frequency converter application must be equipped with PTC having suitable intervention temperature.

In this case, the connection between the temperature-sensitive element to the dedicated protection equipment (not scope of MarelliMotori supply) is mandatory and the control must be set, so that the motor can be used only when the thermal protection equipment is operative.

The use of the motor is dependent on the state of the thermal protections.

GROUNDING

All motors are equipped with two grounding terminals, one inside the terminal box and one outside. Both are dimensioned for connection to suitable earthing wires conforming to EN 50014 standard.

COUPLING

Elastic or flexible couplings must be properly done to avoid the transmission of axial and/or radial loads to the motor shaft and bearings. For possible external axial and/or radial loads contact MarelliMotori.

ANTICONDENSATION HEATERS

Motors subject to atmospheric condensation, either through standing idle in damp environments or because of wide ambient temperature variations, may be fitted with anticondensation heaters. They are normally switched on when the supply to the motor is interrupted, heating the motor to avoid water condensation. Normal feeding voltage is 230V.

Motors from frame size 100 and above can be supplied with anticondensation heaters with terminals in main terminal box or, from 160 frame size and above of category 2G and of category 2D, with terminals in a separate terminal box. The power values normally used are shown in the table below.

Frame Size	Power (W)
100 - 112	8
132	25
160 - 180	50
200 - 250	65
280	100
315	200
355	300
400	400

CONDENSATION DRAINAGE

Motors of category 2G from frame size 160 and above can be supplied on request with condensation drainage holes. This option is advisable, for example, in environments with high humidity levels and large ambient temperature variations.

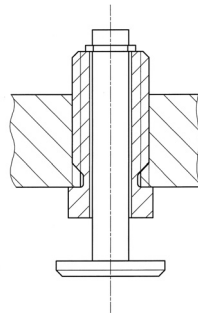

The following table shows some possible configurations of D5 series motors.

Frame Size	Type of Protection	PTC (n°3)	PT100 (n°3)	Anticondensation Heaters	PTC+Heaters	PT100+Heaters
90	d	opt				
	de					
100 - 132	d	opt		opt	opt	
	de	opt		opt		
160 - 250	d	std	opt		opt	
	de	std	opt ⁽¹⁾		opt ⁽¹⁾	opt ⁽¹⁾
280 - 315	d	std	opt		opt	opt
	de	std	opt ⁽¹⁾		opt	opt ⁽¹⁾
355 - 400	d	std	opt		opt	opt
	de	std	opt		opt	opt

std: standard configuration opt: optional

(1) Terminals in separate terminal box only. Option not available on category M2 motors.

For combination of more than one option contact MarelliMotori.

CONNECTION DIAGRAMS

Manually Operated
External Connection
Diagram

Outline
Diagram

Internal Connection
Diagram

MOTORS WITH 6
TERMINALS
Y / Δ CONNECTION

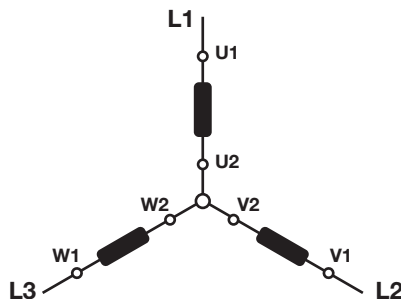
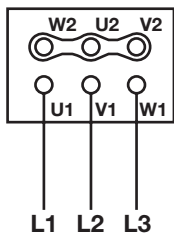
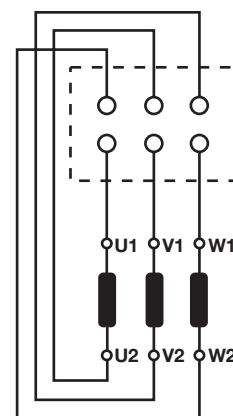
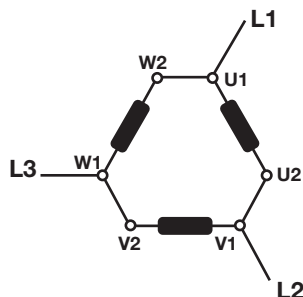
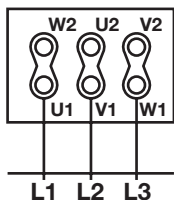

TWO SPEED MOTORS
WITH 6 TERMINALS
Y/Y AND Δ / Δ
CONNECTIONS

Separate
Windings

Low Speed

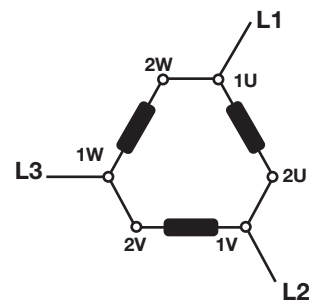
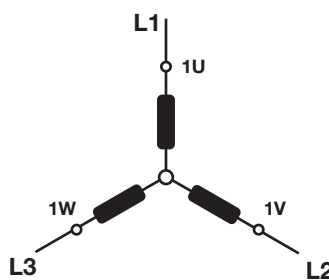
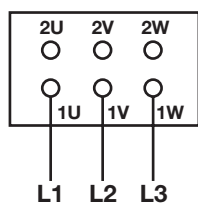

High Speed

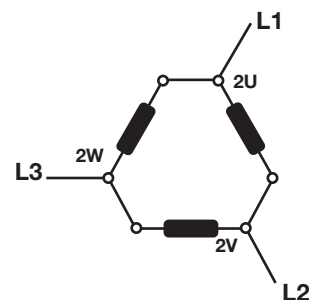
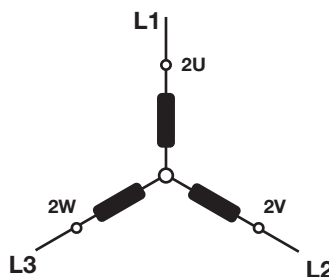
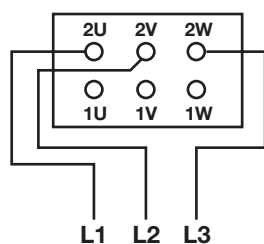

CONNECTION DIAGRAMS

Manually Operated
External Connection
Diagram

Outline
Diagram

Internal Connection
Diagram

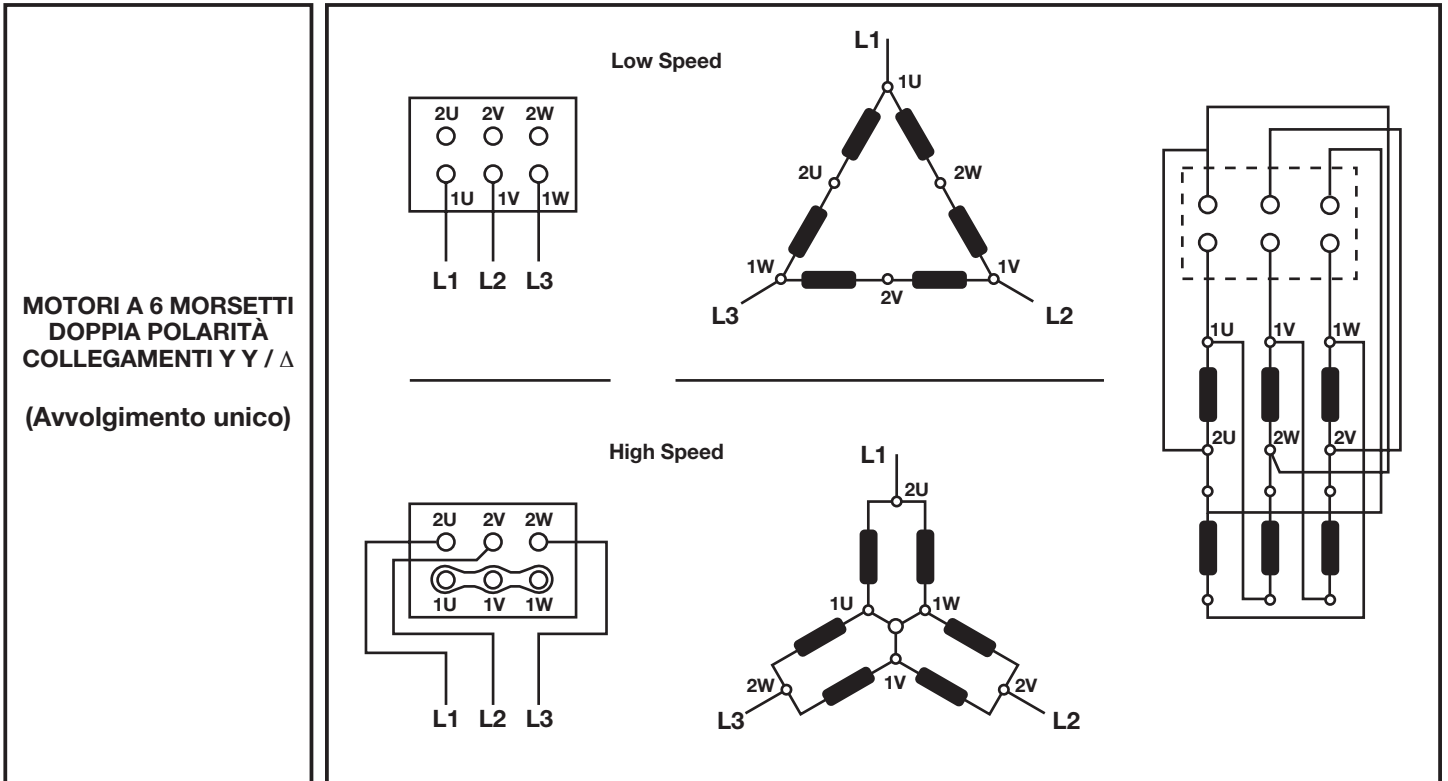

VOLTAGE AND FREQUENCY

The motors described in this catalogue, if not otherwise specified, are designed to operate under feeding voltage of 230V/400V 10% - 50Hz. They are therefore suitable for use on the following supply voltages:

- 220/380V 5%, 50Hz
- 230/400V 5%, 50Hz
- 240/415V 5%, 50Hz

according to standard 60034-1, zone A.

The motors can be supplied with different voltages and frequencies on request.

OUTPUTS AND DERATINGS

The output ratings listed in this catalogue refer to continuous duty S1, rated voltage and frequency, ambient temperature between -20°C and +40°C and altitude up to 1000 m. a.s.l. In different environmental conditions the output ratings of temperature-class-T3 motors can be obtained by applying the derating factors given in the following table:

Altitude	Ambient temperature (°C)				
	40	45	50	55	60
1000	1,00	0,96	0,92	0,87	0,82
1500	0,97	0,93	0,89	0,84	0,79
2000	0,97	0,90	0,86	0,82	0,77
2500	0,90	0,86	0,83	0,78	0,74
3000	0,86	0,82	0,79	0,75	0,70
3500	0,82	0,79	0,75	0,71	0,67
4000	0,77	0,74	0,71	0,67	0,63

EFFICIENCY AND POWER FACTOR

The efficiency (η) and power factor ($\cos \varphi$) values referred to rated output are given in the technical data tables for each motor. The values for other loads can be estimated from the following tables.

Efficiency ($\eta\%$) and power factor ($\cos \varphi$)							
4/4		3/4		2/4		1/4	
η	$\cos \varphi$	η	$\cos \varphi$	η	$\cos \varphi$	η	$\cos \varphi$
97	0,91	97	0,88	96	0,82	92	0,64
96	0,90	96	0,87	94,5	0,80	90	0,63
95	0,89	95	0,86	93,5	0,79	88	0,60
94	0,88	93,5	0,85	92	0,78	86	0,58
93	0,87	93	0,84	91	0,77	85	0,57
92	0,86	92	0,83	90	0,75	84	0,55
91	0,85	91	0,82	89	0,73	82	0,53
90	0,84	90	0,81	87	0,72	90	0,51
89	0,83	89	0,80	86	0,70	79	0,49
88	0,82	88	0,78	85,5	0,67	78,5	0,47
87	0,81	87	0,76	85	0,66	78	0,45
86	0,80	86	0,75	84,5	0,65	77,5	0,43
85	0,79	85	0,73	84	0,63	77	0,42
84	0,78	84	0,73	83	0,60	76	0,41
83	0,77	83	0,72	81	0,59	74	0,40
82	0,76	82	0,70	80,5	0,58	73	0,38
81	0,75	81	0,69	80	0,56	72	0,36
80	0,74	80	0,67	79	0,54	70	0,36
79	0,73	79	0,66	78	0,52	69,5	0,35
78	0,72	78	0,65	76	0,51	69	0,34
77	0,71	77	0,64	75	0,50	68	0,34
76	0,70	76	0,63	74	0,48	67	0,33
75	0,69	75	0,62	73	0,47	66	0,33
74	0,68	74	0,61	72	0,45	64	0,32
73	0,67	73	0,60	71	0,43	63	0,30
72	0,66	72	0,58	69	0,41	61	0,28
71	0,65	71	0,57	68	0,40	59	0,27
70	0,64	70	0,56	67	0,39	58	0,26
69	0,63	69	0,55	66	0,38	57	0,25
68	0,62	68	0,54	65	0,37	55,5	0,24
66	0,61	65,5	0,53	63	0,36	53,5	0,23
64	0,60	63,5	0,52	61	0,35	52	0,22
62	0,59	61,5	0,51	59	0,34	49	0,21
60	0,58	59,5	0,50	57	0,33	47,5	0,20

ELECTRICAL TOLERANCES

Electrical tolerances in accordance with standard IEC 60034-1.

Power factor	-1/6 of (1-cosφ)	min. 0,02 max. 0,07	Locked rotor current	+20%	of guaranteed value
Efficiency	-15% of (1-η) -10% of (1-η)	P _n ≤ 50 kW P _n > 50 kW	Locked rotor torque	-15% +20%	of guaranteed value
Speed	± 20% ± 30% of guaranteed slip	P _n ≥ 1 kW P _n < 1 kW	Pull out torque	-10%	of guaranteed value

MECHANICAL TOLERANCES

Tolerances according to IEC 60072-1 are shown in the following table.
The second shaft extension is built only on request.

Part	Dimension	Tolerance
Shaft Extension	D-DA	from 11 to 28mm ø j6 / 38 to 48mm ø k6 / 55 to 100mm ø m6
Key	F-FA	h9
Flange Concentricity	N	up to frame size 132 j6 / greater than 132 h6
Shaft Height	H	up to frame size 250 - 0,5mm / greater than 250 - 1mm

STANDARD AND SPECIAL TESTS

All MarelliMotori products are subject to routine tests carried out in accordance with CEI/IEC standards. The following additional tests can also be carried out on request

Additional Test	<p>Basic</p> <ul style="list-style-type: none"> • Measurement of winding resistance (cold). • High voltage test plus insulation resistances immediately before and after the test. • Dielectric test. • No load test.
	<p>Complete (= Basic +)</p> <ul style="list-style-type: none"> • Locked rotor test. • Full load winding temperature with method by resistance variation. • Determination of efficiency and power factor at $\frac{1}{4}$, $\frac{2}{4}$ and $\frac{3}{4}$ of load.
Extra Test	<ul style="list-style-type: none"> • On-load test with variable voltage. • Measurement of curve C = f(n). • Measurement of vibration in accordance with IEC 60034-14. • Measurement of noise level, (no load). • Verification of IP protection in accordance with IEC 60034-5.

MOTORS FED BY FREQUENCY CONVERTER

The operating characteristics of the motors described in this section of the catalogue refer to the electrical supply by frequency converter with a commutating frequency higher than 3kHz.

Motors fed by inverter and intended for use in installations in potentially explosive atmospheres must be:

- explicitly requested for this type of supply,
- specifically chosen considering the load and speed range,
- using appropriate passive thermal protection (thermistors, PT100), with connection to suitable supply system protection apparatus.
- given a nameplate identifying: supply characteristics of the frequency converter, torque and speed range.

The maximum supply frequency value is dependent on the frame and polarity of the motor, as shown in the following table.

Frame Size	N° poles	Temperature class T3	Temperature class T4
71 to 400	2	60 Hz	60 Hz
71 to 400	≥ 4	100 Hz	75 Hz

For motors ≥ 4 poles and supply frequency between 75-100 Hz contact MarelliMotori.
The performances of motors fed by frequency converter are given in the specific tables.

EFFECTS OF INVERTER SUPPLY ON THE MOTOR

A motor supplied by a frequency converter (inverter) does not receive a purely sinusoidal feed (voltage, current), which leads to an increase in:

- additional losses,
- noise and vibrations,
- stresses on the electrical insulation,

As well as:

- the production of voltages and currents in the bearings,
- the need to provide additional solutions to satisfy the EMC requirements for the installation.

ADDITIONAL LOSSES

Additional losses increase the heat of the motor, which may lead to an increase in the temperature of the bearings.

These effects must be considered (by using appropriate derating with respect to the supply by the mains), in particular for potentially explosive environments where limits to the maximum surface temperature are applied.

NOISE VIBRATION

The increase in magnetic noise depends mainly on the commutating frequency of the inverter and as well as the harmonic content.

Self-ventilated motors, when running at frequencies higher than the rated value, give an increased noise level due to the increased ventilation. For speed values higher than the rated one, the maximum speed reachable by the motor or the critical speed of the system must not be exceeded.

In this case, the use of separate ventilation is recommended to reduce any possible excessive noise.

EFFECTS ON ELECTRICAL INSULATION

The insulation system in a motor is subjected to an increased dielectric effect when fed by an inverter. Depending on the supply system characteristics, the indications given in the paragraph "Instructions for the correct use of motors fed by frequency converter" must be considered.

GENERATION OF VOLTAGE AND CURRENT IN THE BEARINGS

The inverter induces high frequency voltages into the shaft, possibly causing bearing currents which must be avoided in all motors for potentially explosive atmospheres.

The paragraph "Instructions for the correct use of motors fed by frequency converter" gives the indications which must be followed for the use of insulated bearings / supports or of appropriate filters between the inverter and motor to avoid the risk of current circulation in the bearings.

D5 series motors from 280 to 400 frame size when designed for inverter application, are supplied with insulated N-End bearings.

EMC REQUIREMENTS FOR THE INSTALLATION

The use of cables and connections conforming to EMC (electromagnetic compatibility) recommendations is necessary. Supply cables to the motor must be both shielded and symmetrical. The motor and the driven system must be properly earthed, to avoid possible voltages and currents in the bearings of the motor. The additional instructions given by the inverter manufacturer must also be followed.

INSTRUCTIONS FOR THE CORRECT USE OF MOTORS FED BY FREQUENCY CONVERTER

The type of the inverter and of the filters must be properly selected to guarantee a peak voltage at the motor terminals of less than 1060V.

The following table indicates the solutions to be applied on motors fed by frequency converters. They are classified with respect to the input voltage of the inverter.

Frame Size \ Voltage	$U_N \leq 500V$	$U_N \leq 690V$
≤ 250	Standard insulation	Standard insulation + filter dU/dt (*)
280 ÷ 315	Reinforced insulation + insulated bearing	Reinforced insulation + Insulated bearing + filter dU/dt (*)
355 ÷ 400	Reinforced insulation + insulated bearing	Reinforced insulation + Insulated bearing + filter dU/dt (*) + common mode filter (*)

(*) Not scope of MarelliMotori supply.

SELF-VENTILATED MOTORS

The ventilation in a self-ventilated motor is a function of the speed of the motor itself (and therefore also of the feeding frequency). Consequently the cooling and noise level vary according to the inverter output frequency, thus:

- in the frequency range lower than the rated value, a further power derating must be considered (see the relevant graphs in the dedicated section)
- in the frequency range higher than the rated value, the noise increases approximately by the values given in the following table:

Frequency [Hz]	60	75
Additional noise [dB(A)]	4 - 5	9

MOTORS WITH FORCED VENTILATION

Forced ventilated motors are equipped with an auxiliary motor which must have a classification compatible with the main one. The use of forced ventilation is recommended in the presence of wide range of speed variation and when constant torques are requested. The operation of the main motor must be made dependent to the correct operation of the forced ventilation unit.

For the correct selection of motors fed by inverters, refer to the corresponding specific tables.

Frame size	Forced Ventilated Motor		Force Ventilation Unit	
	ΔI B3 [mm]	ΔI V1 [mm]	Δp [kg]	Type
160-250	236	268	23-30	D5_71 MB4
280-315S	180-220	255-315	35-45	D5_80 MA4
315M	310	-	40	D5_80 MA4
355	256	-	40	D5_80 MB4
400	325	-	95	D5_112 M4

RATED OUTPUT kW		MOTOR TYPE	PERFORMANCE AT RATED OUTPUT						PERFORMANCE AT RATED VOLTAGE			MOMENT OF INERTIA J kgm ²	WEIGHT IM 1001 Approx. kg
			SPEED		EFFICIENCY η %	POWER FACTOR cos φ	400V 50Hz						
			n 1/min	50 Hz			60 Hz	RATED CURRENT I A	RATED TORQUE T _n Nm	STARTING CURRENT I _s /I _n p.u.	STARTING TORQUE T _s /T _n p.u.		

3000/3600 min⁻¹ = 2 poles - 50/60 Hz

T1 ÷ T4, T 135°C

0,37	0,37	71 MA2	2730	3330	69,5	0,78	1,0	1,3	4,4	2,8	-	0,0004	15,3
0,55	0,55	71 MB2	2730	3330	72,3	0,79	1,4	1,9	4,6	3,0	-	0,0005	17,3
0,75	0,75	80 MA2	2800	3400	74,1	0,83	1,8	2,6	5,6	2,4	2,3	0,0008	20,8
1,1	1,1	80 MB2	2830	3430	77,5	0,84	2,4	3,7	5,9	2,6	2,6	0,0010	22,8
1,5	1,6	90 S2	2810	3410	78,7	0,84	3,3	5,1	6,1	2,5	2,6	0,0016	26,8
2,2	2,3	90 L2	2850	3450	81,1	0,83	4,7	7,4	6,4	2,7	2,8	0,0022	32,3
3	3,2	100 LA2	2900	3500	83,0	0,84	6,2	9,9	6,8	2,1	2,6	0,0050	48,3
4	4,2	112 M2	2910	3510	84,4	0,85	8,1	13,1	7,2	2,5	2,9	0,0063	55,8
5,5	6	132 SA2	2915	3515	85,7	0,85	10,9	18,1	7,5	2,5	2,8	0,0160	75,8
7,5	8	132 SB2	2915	3515	87,0	0,87	14,3	24,7	7,8	2,6	3,2	0,0190	81,8
9	9,5	132 MB2	2915	3515	87,2	0,87	17,1	29,5	7,8	2,9	3,6	0,0230	91,8
11	12	160 MA2	2920	3520	88,4	0,82	21,9	36	6,2	2,1	2,8	0,030	115
15	16,5	160 MB2	2925	3525	89,8	0,83	29,0	49	6,6	2,4	3,0	0,035	129
18,5	20	160 L2	2925	3525	90,0	0,81	36,7	60	7,1	2,6	3,0	0,040	143
22	24	180 M2	2930	3530	90,5	0,84	41,8	72	7,0	2,5	3,0	0,048	154
30	33	200 LA2	2945	3545	92,0	0,87	54	97	6,8	2,3	2,9	0,165	189
37	40	200 LB2	2945	3545	92,2	0,87	67	120	6,9	2,4	3,0	0,180	209
45	50	225 M2	2960	3560	92,5	0,88	80	145	6,6	2,4	3,0	0,225	304
55	60	250 M2	2960	3560	93,0	0,87	98	177	6,7	2,4	3,0	0,250	336
75	83	280 S2	2960	3560	93,6	0,87	133	242	6,8	2,3	2,7	0,350	484
90	100	280 M2	2960	3560	94,2	0,88	157	290	7,2	2,3	2,7	0,416	517
110	121	315 SM2	2975	3575	94,3	0,87	194	353	6,4	2,4	2,4	0,95	760
132	158	315 MA2	2970	3570	94,3	0,86	235	424	6,5	2,5	2,5	0,95	760
160	192	315 MC2	2975	3575	94,4	0,87	281	513	6,5	2,5	2,5	1,12	827
200	240	315 MD2	2980	3580	94,7	0,87	351	640	6,5	2,5	2,5	1,30	887

T1 ÷ T3, T 150°C

230	280	355 LX2	2980	3580	94,5	0,90	390	736	6,5	2,0	2,8	4,4	1770
280	330	355 LW2	2980	3580	95,4	0,90	471	896	6,5	2,0	3,0	5,1	1950
330	400	355 LY2	2980	3580	95,8	0,91	547	1056	6,8	2,1	3,0	6,0	2145
375	450	400 LX2	2980	3580	94,5	0,91	630	1201	7,0	2,2	2,8	7,9	2780
450	540	400 LW2	2980	3580	95,0	0,91	752	1441	7,0	2,2	3,0	8,9	2940
560	630	400 LY2	2980	3580	95,0	0,91	936	1793	7,2	2,2	3,0	10,0	3150

T4, T 135°C

200	200	355 LX2	2980	3580	94,5	0,90	339	640	6,5	2,0	2,8	4,4	1770
250	250	355 LW2	2980	3580	95,4	0,90	420	800	6,5	2,0	3,0	5,1	1950
280	280	355 LY2	2980	3580	95,8	0,91	464	896	6,8	2,1	3,0	6,0	2145
330	330	400 LX2	2980	3580	94,5	0,91	555	1056	7,0	2,2	2,8	7,9	2780
400	400	400 LW2	2980	3580	95,0	0,91	669	1281	7,0	2,2	3,0	8,9	2940
500	500	400 LY2	2980	3580	95,0	0,91	936	1601	7,2	2,2	3,0	10,0	3150

I_s = Starting current, T_s = Starting torque, T_{MAX} = Breakdown torque.

Detailed data for 440V/60Hz on request.

• Motor not multivoltage. Output values at 440V/60Hz refer to motors with dedicated winding.

RATED OUTPUT kW		MOTOR TYPE	PERFORMANCE AT RATED OUTPUT					PERFORMANCE AT RATED VOLTAGE					MOMENT OF INERTIA J kgm ²	WEIGHT IM 1001 Approx. kg
			SPEED		EFFICIENCY η %	POWER FACTOR cos φ	400V 50Hz							
			n 1/min				RATED CURRENT I A	RATED TORQUE T _n Nm	STARTING CURRENT I _s /I _n p.u.	STARTING TORQUE T _s /T _n p.u.	BREAKDOWN TORQUE T _{MAX} /T _n p.u.			
50 Hz	60 Hz		50 Hz	60 Hz										

1500/1800 min⁻¹ = 4 poles - 50/60 Hz

T1 ÷ T4, T 135°C

0,25 0,37	0,25 0,37	71 MA4 71 MB4	1380 1380	1680 1680	67,6 69,5	0,68 0,68	0,8 1,1	1,73 2,6	3,8 3,8	2,3 2,5	2,3 2,5	0,0005 0,0006	16,3 17,3
0,55 0,75	0,55 0,75	80 MA4 80 MB4	1380 1385	1680 1685	72,0 73,0	0,74 0,74	1,5 2,0	3,8 5,2	4,6 4,75	2,6 2,75	2,4 2,5	0,0013 0,0016	21,3 22,8
1,1 1,5	1,2 1,6	90 S4 90 L4	1390 1390	1690 1690	76,5 79,1	0,79 0,82	2,6 3,4	7,6 10,3	4,5 4,7	2,5 2,7	2,4 2,5	0,0033 0,0040	27,3 31,8
2,2 3	2,3 3,2	100 LA4 100 LB4	1420 1420	1720 1720	81,1 83,0	0,81 0,81	4,9 6,4	14,8 20,2	5,3 5,5	2,0 2,1	2,3 2,5	0,0073 0,0090	46,8 50,8
4	4,4	112 M4	1425	1720	84,2	0,83	8,3	26,8	5,7	2,4	2,7	0,0115	59,3
5,5 7,5	5,8 7,9	132 SA4 132 MA4	1440 1450	1740 1750	85,7 87,4	0,82 0,84	11,4 14,8	36,5 49,4	6,5 6,7	2,0 2,2	2,6 2,75	0,0238 0,0300	78,3 91,3
11 15 18,5	12 16 20	160 M4 160 L4 180 M4	1455 1460 1460	1760 1760 1765	88,6 89,4 90,0	0,81 0,81 0,82	22,1 29,9 36,2	72 98 121	5,2 5,8 6,2	2,0 2,2 2,3	2,1 2,4 2,5	0,034 0,075 0,090	123 135 148
22	24	180 L4	1465	1765	90,5	0,84	41,8	143	6,3	2,4	2,5	0,110	177
30	33	200 L4	1470	1765	91,6	0,84	56	195	6,4	2,4	2,8	0,180	205
37 45	40 50	225 S4 225 M4	1475 1475	1770 1775	92,5 92,5	0,86 0,86	67 82	239 291	6,5 6,5	2,3 2,4	2,8 2,8	0,320 0,410	302 332
55	60	250 M4	1475	1775	93,0	0,87	98	356	6,4	2,3	2,6	0,520	370
75 90	83 100	280 S4 280 M4	1480 1480	1780 1780	93,7 93,9	0,86 0,88	134 157	483 580	7,0 7,1	2,5 2,7	2,3 2,4	0,885 1,060	525 584
110 132 160 200	121 158 192 240	315 SM4 315 MA4 315 MC4 315 MD4	1488 1485 1485 1485	1780 1785 1785 1785	93,6 94,5 94,8 95,3	0,85 0,85 0,85 0,86	200 237 287 353	705 848 1028 1285	6,5 6,2 6,2 6,5	2,6 2,5 2,5 2,5	2,6 2,5 2,5 2,6	2,10 2,10 2,50 3,10	780 780 859 965

T1 ÷ T3, T 150°C

250 300 330	300 350 400	355 LX4 355 LW4 355 LY4	1490 1490 1490	1790 1790 1790	95,4 95,4 95,7	0,87 0,87 0,87	435 522 572	1601 1921 2113	6,8 6,8 6,8	2,2 2,2 2,2	2,1 2,4 2,5	7,5 9,3 11,2	1730 1960 2180
375 450 560	450 540 630	400 LX4 400 LW4 400 LY4	1490 1490 1490	1790 1790 1790	95,5 95,5 95,5	0,88 0,88 0,88	644 773 962	2401 2881 3586	6,8 6,8 6,8	2,3 2,3 2,3	2,1 2,4 2,5	15,8 18,8 20,7	2880 3030 3240

T4, T 135°C

210 270 300	210 270 300	355 LX4 355 LW4 355 LY4	1490 1490 1490	1790 1790 1790	95,3 95,5 95,5	0,86 0,87 0,87	370 469 521	1345 1729 1921	6,8 6,8 6,8	2,2 2,2 2,2	2,4 2,4 2,5	7,5 9,3 11,2	1730 1960 2180
330 400 500	330 400 500	400 LX4 400 LW4 400 LY4	1490 1490 1490	1790 1790 1790	95,1 95,5 95,5	0,88 0,88 0,88	569 687 859	2113 2561 3201	6,8 6,8 7,2	2,3 2,3 1,2	2,2 2,3 2,5	15,8 18,8 20,7	2880 3030 3240

I_s = Starting current, T_s = Starting torque, T_{MAX} = Breakdown torque.

Detailed data for 440V/60Hz on request.

• Motor not multivoltage. Output values at 440V/60Hz refer to motors with dedicated winding.

RATED OUTPUT kW		MOTOR TYPE	PERFORMANCE AT RATED OUTPUT					PERFORMANCE AT RATED VOLTAGE					MOMENT OF INERTIA J kgm ²	WEIGHT IM 1001 Approx. kg
			SPEED		EFFICIENCY η %	POWER FACTOR cos φ	400V 50Hz							
			n 1/min				RATED CURRENT I A	RATED TORQUE T _n Nm	STARTING CURRENT I _s /I _n p.u.	STARTING TORQUE T _s /T _n p.u.	BREAKDOWN TORQUE T _{MAX} /T _n p.u.			
50 Hz	60 Hz		50 Hz	60 Hz										

1000/1200 min⁻¹ = 6 poles - 50/60 Hz

T1 ÷ T4, T 135°C

0,37 0,55	0,44 0,66	80 MA6 80 MB6	930 930	1130 1130	65,2 68,0	0,72 0,73	1,1 1,6	3,8 5,6	3,6 3,9	1,9 2,1	2,25 2,4	0,0024 0,0028	21,3 23,3
0,75 1,1	0,9 1,3	90 S6 90 L6	930 930	1130 1130	71,1 74,5	0,73 0,71	2,1 3,0	7,7 11,3	4,6 4,8	2,1 2,5	2,3 2,6	0,0038 0,0050	27,8 34,3
1,5 2,2	1,8 2,6	100 LA6 112 M6	940 940	1140 1140	75,3 78,2	0,75 0,75	3,8 5,4	15,2 22,3	5,1 5,3	2,0 2,0	2,3 2,5	0,0100 0,0150	47,3 56,3
3 4 5,5	3,6 4,8 6,6	132 SA6 132 MA6 132 MB6	950 950 950	1150 1150 1150	80,1 81,0 82,0	0,76 0,78 0,78	7,1 9,1 12,4	30,2 40,2 55,3	5,5 5,7 6,2	2,1 2,3 2,5	2,4 2,6 2,8	0,0300 0,0380 0,0460	72,8 83,8 93,8
7,5 11	9 13,2	160 M6 160 L6	965 967	1165 1165	86,0 88,0	0,82 0,82	15,4 22,0	74 108	5,0 5,5	2,0 2,3	2,3 2,5	0,087 0,110	131 147
15	18	180 L6	970	1170	88,2	0,82	30,0	147	5,2	2,3	2,2	0,130	165
18,5 22	22 26	200 LA6 200 LB6	970 972	1170 1170	88,2 89,0	0,83 0,83	36 43	182 216	5,2 5,5	2,1 2,4	2,3 2,4	0,170 0,220	185 203
30	36	225 M6	975	1175	90,5	0,84	57	294	6,2	2,4	2,4	0,470	309
37	44	250 M6	975	1175	91,0	0,84	70	362	6,5	2,6	2,6	0,570	342
45 54 55	54 66	280 S6 280 M6	980 980	1180 1180	92,5 93,0	0,83 0,84	85 102	438 535	6,0 6,0	2,5 2,5	2,5 2,5	0,850 1,075	479 518
75 90 110 132 160	90 108 132 158 192	315 SM6 315 MA6 315 MB6 315 MC6 315 MD6	985 985 985 985 985	1185 1185 1185 1185 1185	94,0 94,0 94,0 93,3 94,8	0,83 0,84 0,84 0,85 0,86	139 165 201 240 283	726 872 1065 1278 1550	6,3 6,0 6,0 6,3 6,3	2,6 2,5 2,5 2,5 2,7	2,6 2,5 2,5 2,5 2,5	2,60 2,60 3,00 3,60 4,40	748 748 799 889 994

T1 ÷ T3, T 150°C

200 250 280	240 300 330	355 LX6 355 LW6 355 LY6	990 990 990	1190 1190 1190	95,0 95,0 95,0	0,86 0,86 0,86	354 442 493	1927 2409 2698	6,2 6,5 6,5	2,2 2,2 2,2	2,3 2,5 2,2	11,2 14,0 15,5	1820 2060 2190
315 355 400	380 420 480	400 LX6 400 LW6 400 LY6	995 995 995	1190 1190 1190	95,0 95,0 95,0	0,87 0,87 0,87	551 621 699	3020 3404 3835	6,5 6,5 6,5	2,1 2,1 2,1	2,3 2,5 2,2	22,7 25,5 29,0	2860 3040 3300

T4, T 135°C

160 230 250	160 230 250	355 LX6 355 LW6 355 LY6	990 990 990	1190 1190 1190	95,0 95,0 95,0	0,86 0,86 0,86	283 407 440	1542 2216 2409	6,8 7,0 7,0	2,3 2,3 2,3	2,5 2,6 2,4	11,2 14,0 15,5	1820 2060 2190
280 315 350	280 315 350	400 LX6 400 LW6 400 LY6	995 995 995	1194 1194 1194	95,0 95,0 95,0	0,87 0,87 0,87	490 551 612	2685 3020 3356	6,8 6,8 7,0	2,2 2,2 2,2	2,4 2,4 2,4	22,7 25,5 29,0	2860 3040 3300

I_s = Starting current, T_s = Starting torque, T_{MAX} = Breakdown torque.

Detailed data for 440V/60Hz on request.

The motors shown on this page are not multivoltage. Output values at 440V/60Hz refer to motors with dedicated winding.

RATED OUTPUT kW		MOTOR TYPE	PERFORMANCE AT RATED OUTPUT						PERFORMANCE AT RATED VOLTAGE			MOMENT OF INERTIA J kgm ²	WEIGHT IM 1001 Approx. kg
			SPEED		EFFICIENCY η %	POWER FACTOR cos φ	400V 50Hz						
			n 1/min	50 Hz			60 Hz	RATED CURRENT I A	RATED TORQUE T _n Nm	STARTING CURRENT I _s /I _n p.u.	STARTING TORQUE T _s /T _n p.u.		

750/900 min⁻¹ = 8 poles - 50/60 Hz

T1 ÷ T4, T 135°C

0,18	0,22	80 MA8	660	810	53,0	0,72	0,7	2,6	3,5	2,0	1,8	0,0024	21,8
0,25	0,3	80 MB8	690	860	56,3	0,67	1,0	3,5	3,5	2,0	1,8	0,0027	22,8
0,37	0,44	90 S8	675	825	59,3	0,66	1,4	5,2	3,5	2,0	1,8	0,0037	27,3
0,55	0,66	90 L8	695	845	63,3	0,64	2,0	7,6	3,5	2,0	1,8	0,0050	35,8
0,75	0,9	100 LA8	680	830	70,5	0,69	2,2	10,5	4,0	2,1	2,0	0,0093	45,3
1,1	1,32	100 LB8	695	845	71,5	0,69	3,2	15,1	4,1	2,3	2,3	0,0123	50,3
1,5	1,8	112 M8	700	850	73,0	0,70	4,2	20,5	4,4	2,4	2,4	0,0168	58,8
2,2	2,6	132 SA8	710	840	75,0	0,74	5,7	29,6	4,4	2,0	2,2	0,0380	78,8
3	3,6	132 MA8	705	845	77,0	0,76	7,4	40,6	4,6	2,1	2,3	0,0460	92,8
4	4,8	160 MA8	710	860	81,5	0,73	9,7	54	4,2	1,9	2,1	0,080	115
5,3	6,6	160 MB8	720	870	82,4	0,74	13,0	73	4,2	1,9	2,1	0,092	123
7,5	9	160 L8	720	870	84,7	0,74	17,3	99	4,2	2,0	2,1	0,110	133
11	13,2	180 L8	725	875	86,7	0,75	24,4	145	4,5	2,0	2,2	0,160	188
15	18	200 L8	725	875	88,0	0,75	33	197	5,0	2,1	2,3	0,220	216
18,5	22	225 S8	730	880	89,0	0,76	40	242	5,2	2,2	2,4	0,420	294
22	26	225 M8	730	880	90,0	0,76	47	288	5,3	2,2	2,4	0,520	326
30	36	250 M8	730	880	91,0	0,76	63	392	5,5	2,3	2,5	0,620	356
37	44	280 S8	735	885	92,5	0,80	72	480	6,0	2,5	2,5	1,050	520
45	54	280 M8	735	885	93,0	0,80	87	584	6,0	2,5	2,5	1,250	553
55	66	315 SM8	740	890	93,5	0,81	105	709	6,5	2,3	2,4	2,80	776
75	90	315 MA8	740	890	93,8	0,82	141	967	6,0	2,1	2,2	2,80	776
90	108	315 MC8	740	890	94,4	0,83	166	1160	6,2	2,2	2,3	3,50	886
110	132	315 MD8	740	890	94,5	0,83	202	1418	6,2	2,2	2,3	4,00	924
132	158	315 ME8	740	890	94,6	0,83	243	1702	6,2	2,2	2,3	4,30	993

T1 ÷ T3, T 150°C

160	180	355 LX8	740	890	94,8	0,84	290	2063	6,0	1,4	2,2	13,2	1840
200	240	355 LW8	743	890	95,3	0,84	361	2568	6,2	1,4	2,3	16,2	2040
220	270	355 LY8	744	893	95,6	0,85	391	2821	6,7	1,8	2,5	18,0	2170
250	300	400 LX8	745	893	95,6	0,80	472	3201	6,2	2,0	2,1	25,0	2760
280	330	400 LW8	745	894	95,5	0,80	530	3586	6,2	2,0	2,1	29,7	2940
315	380	400 LY8	745	894	95,6	0,80	595	4034	6,2	2,0	2,1	33,2	3200

T4, T 135°C

150	150	355 LX8	740	890	94,8	0,84	272	1934	6,6	1,5	2,4	13,2	1840
180	180	355 LW8	743	893	95,3	0,84	325	2311	6,8	1,5	2,5	16,2	2040
200	200	355 LY8	744	894	95,6	0,85	356	2565	7,2	2,0	2,6	18,0	2170
230	230	400 LX8	745	895	95,6	0,81	429	2945	6,6	2,1	2,2	25,0	2760
250	250	400 LW8	745	895	95,5	0,82	461	3201	6,8	2,2	2,3	29,7	2940
280	280	400 LY8	745	895	95,6	0,83	510	3586	6,8	2,2	2,2	33,2	3200

I_s = Starting current, T_s = Starting torque, T_{MAX} = Breakdown torque.

Detailed data for 440V/60Hz on request.

The motors shown on this page are not multivoltage. Output values at 440V/60Hz refer to motors with dedicated winding.

RATED OUTPUT kW	MOTOR TYPE	PERFORMANCE AT RATED OUTPUT					PERFORMANCE AT RATED VOLTAGE					MOMENT OF INERTIA J kgm ²	WEIGHT IM 1001 Approx. kg
		SPEED		EFFICIENCY η %	POWER FACTOR cos φ	400V 50Hz							
		n 1/min				RATED CURRENT I A	RATED TORQUE T _n Nm	STARTING CURRENT I _s /I _n p.u.	STARTING TORQUE T _s /T _n p.u.	BREAKDOWN TORQUE T _{MAX} /T _n p.u.			
50 Hz	60 Hz	50 Hz	60 Hz										

600/720 min⁻¹ = 10 poles - 50/60 Hz

T1 ÷ T3, T 150°C

45	54	315 SM10	590	710	0,79	91,9	89	728	5,0	1,4	1,6	4,00	776
55	66	315 MA10	590	710	0,78	92,0	111	889	5,0	1,4	2,6	4,00	776
75	90	315 MC10	590	710	0,79	92,1	149	1213	4,8	1,2	2,5	4,70	856
90	110	315 MD10	590	710	0,79	93,0	177	1455	4,5	1,1	2,3	5,50	924

T1 ÷ T3, T 150°C

110	132	355 LX10	590	710	94,0	0,78	217	1779	6,2	1,9	2,1	14,5	1900
132	160	355 LW10	590	710	94,5	0,78	259	2134	6,2	1,9	2,1	17,5	2100
160	180	355 LY10	590	710	95,0	0,78	312	2587	6,2	1,9	2,1	20,7	2230
180	210	400 LX10	595	713	95,0	0,78	351	2886	6,2	1,8	2,0	28,0	2850
200	240	400 LW10	595	713	95,0	0,78	390	3207	6,2	1,8	2,0	33,0	2950
225	270	400 LY10	595	713	95,0	0,78	439	3608	6,2	1,8	2,0	36,0	3220

T4, T 135°C

100	100	355 LX10	590	710	94,0	0,78	197	1617	6,8	2,0	2,3	14,5	1900
120	120	355 LW10	590	710	94,5	0,78	235	1940	6,8	2,0	2,3	17,5	2100
140	140	355 LY10	590	710	95,0	0,78	273	2264	6,2	2,0	2,3	20,7	2230
160	160	400 LX10	595	715	95,0	0,78	312	2565	6,8	1,9	2,2	28,0	2850
180	180	400 LW10	595	715	95,0	0,78	351	2886	6,8	1,9	2,2	33,0	2950
200	200	400 LY10	595	715	95,0	0,78	390	3207	6,8	1,9	2,2	36,0	3220

500/600 min⁻¹ = 12 poles - 50/60 Hz

T1 ÷ T3, T 150°C

37	45	315 SM12	490	590	0,77	90,7	76	720	4,8	1,5	2,4	4,00	776
45	54	315 MA12	490	590	0,76	90,7	94	876	4,8	1,5	2,4	4,00	776
55	66	315 MC12	490	590	0,77	92,0	112	1071	5,2	1,4	2,5	4,70	856
75	90	315 MD12	490	590	0,77	92,0	153	1460	4,3	1,2	2,1	5,50	924

T1 ÷ T3, T 150°C

90	110	355 LX12	490	590	93,0	0,76	184	1752	5,7	1,4	2,7	14,5	1900
110	132	355 LW12	491	590	93,5	0,76	224	2137	5,7	1,4	2,7	17,5	2100
132	160	355 LY12	491	590	93,5	0,77	265	2565	5,8	1,5	2,8	20,7	2230
160	180	400 LX12	495	583	94,0	0,78	315	3084	6,0	1,6	1,9	28,0	2850
180	210	400 LW12	495	594	94,5	0,78	353	3469	6,0	1,6	1,9	33,0	2950
200	240	400 LY12	495	594	94,5	0,78	392	3855	6,0	1,6	1,9	36,0	3220

T4, T 135°C

80	80	355 LX12	490	590	93,0	0,76	164	1558	6,2	1,5	2,8	14,5	1900
100	100	355 LW12	491	590	93,5	0,76	203	1943	6,2	1,5	2,8	17,5	2100
110	110	355 LY12	491	590	93,5	0,77	221	2137	6,4	1,6	2,8	20,7	2230
140	140	400 LX12	495	595	94,0	0,78	276	2698	6,6	1,7	2,1	28,0	2850
160	160	400 LW12	495	595	94,5	0,78	314	3084	6,6	1,7	2,1	33,0	2950
180	180	400 LY12	495	595	94,5	0,78	353	3469	6,0	1,7	2,1	36,0	3220

I_s = Starting current, T_s = Starting torque, T_{MAX} = Breakdown torque.

Detailed data for 440V/60Hz on request.

The motors shown on this page are not multivoltage. Output values at 440V/60Hz refer to motors with dedicated winding.

RATED OUTPUT kW	MOTOR TYPE	PERFORMANCE AT RATED OUTPUT						PERFORMANCE AT RATED VOLTAGE			MOMENT OF INERTIA J kgm ²	WEIGHT IM 1001 Approx. kg
		SPEED		EFFICIENCY η %	POWER FACTOR cos φ	400V 50Hz						
		n 1/min	50 Hz			60 Hz	RATED CURRENT I A	RATED TORQUE T _n Nm	STARTING CURRENT I _s /I _n p.u.	STARTING TORQUE T _s /T _n p.u.		

3000/3600 min⁻¹ = 2 poles - 50/60 Hz

T5, T 100°C

0,37 0,55	0,37 0,55	71 MA2 71 MB2	2730 2730	3350 3360	69,5 72,3	0,78 0,79	1,0 1,4	1,3 1,9	4,4 4,6	2,8 3,0	- -	0,0004 0,0005	15,3 17,3
0,75 1,1	0,75 1,1	80 MA2 80 MB2	2800 2830	3430 3470	74,1 77,5	0,83 0,84	1,8 2,4	2,6 3,7	5,6 5,9	2,4 2,6	2,3 2,6	0,0008 0,0010	20,8 22,8
1,5 2,2	1,5 2,2	90 S2 90 L2	2810 2850	3460 3480	78,7 81,1	0,84 0,83	3,3 4,7	5,1 7,4	6,1 6,4	2,5 2,7	2,6 2,9	0,0016 0,0022	26,8 32,3
3,0	3,0	100 LA2	2900	3510	83,0	0,84	6,2	9,9	6,8	2,1	2,6	0,0050	48,3
5,5 7,5 9,0	5,5 7,5 9,0	132 SA2 132 SB2 132 MB2	2905 2905 2915	3490 3510 3520	85,7 87,0 87,2	0,85 0,87 0,87	10,9 14,3 17,1	18,1 24,7 29,5	7,5 7,8 7,8	2,5 2,6 2,9	2,8 3,2 3,6	0,0160 0,0190 0,0230	75,8 81,8 91,8
11 15 18,5	12,5 17 21	160 MA2 160 MB2 160 L2	2900 2910 2925	3500 3510 3525	86 87 89	0,83 0,84 0,83	22,2 29,6 36,2	36 49 60	6,2 6,4 6,8	2,1 2,2 2,4	2,8 3,0 3,0	0,030 0,035 0,040	115 129 143
22	25	180 M2	2930	3530	88,5	0,77	46,7	72	6,8	2,4	3,0	0,048	154
30 37	36 42,5	200 LA2 200 LB2	2945 2950	3545 3550	90 91	0,87 0,87	55 68	97 120	6,7 6,5	2,3 2,4	2,9 3,0	0,165 0,180	189 209
40,5	46,5	225 M2	2960	3560	92	0,88	72	131	6,7	2,4	3,0	0,225	304
50	57,5	250 M2	2955	3555	90	0,86	93	161	6,7	2,4	3,0	0,250	336
70 84	80,5 96,5	280 S2 280 M2	2955 2955	3560 3560	92 92	0,87 0,88	126 150	226 271	6,8 7,2	2,3 2,3	2,7 2,7	0,350 0,416	484 527
110 120 145 185	125 138 160 213	315 SM2 315 MA2 315 MC2 315 MD2	2975 2970 2975 2980	3570 3570 3575 3580	92,5 92 93,5 93,5	0,84 0,86 0,86 0,87	205 219 261 329	353 385 465 592	7,5 6,8 6,8 6,8	2,4 2,5 2,6 2,6	2,7 2,6 2,6 2,6	0,950 0,950 1,120 1,300	760 760 827 887

1500/1800 min⁻¹ = 4 poles - 50/60 Hz

T5, T 100°C

0,25 0,37	0,25 0,37	71 MA4 71 MB4	1380 1380	1700 1710	67,6 69,5	0,68 0,68	0,8 1,1	1,73 2,6	3,8 3,8	2,3 2,5	2,3 2,5	0,0005 0,0006	16,3 17,3
0,55 0,75	0,55 0,75	80 MA4 80 MB4	1380 1385	1685 1720	72,0 73,0	0,74 0,74	1,5 2,0	3,8 5,2	4,6 4,75	2,6 2,8	2,4 2,5	0,0013 0,0016	21,3 22,8
1,1 1,5	1,1 1,5	90 S4 90 L4	1390 1390	1720 1705	76,5 79,1	0,79 0,82	2,6 3,4	7,6 10,3	4,5 4,7	2,5 2,7	2,4 2,5	0,0033 0,0040	27,3 31,8
2,2 3,0	2,2 3,0	100 LA4 100 LB4	1420 1420	1725 1730	81,1 83,0	0,81 0,81	4,9 6,4	14,8 20,2	5,3 5,5	2,0 2,1	2,3 2,5	0,0073 0,0090	46,8 50,8
5,5 7,5	5,5 7,5	132 SA4 132 MA4	1440 1450	1755 1760	85,7 87,4	0,82 0,84	11,4 14,8	36,5 49,4	6,5 6,7	2,0 2,2	2,6 2,75	0,0238 0,0300	78,3 91,3
11 15	12,5 17	160 M4 160 L4	1455 1455	1755 1755	87 87	0,81 0,81	22,5 30,7	72 98	5,2 5,8	2,0 2,2	2,1 2,4	0,063 0,075	123 135
18,5 22	21 26	180 M4 180 L4	1460 1465	1760 1765	88 90	0,81 0,85	37,5 41,5	121 143	6,2 6,3	2,3 2,4	2,5 2,5	0,090 0,110	148 177
27	32	200 L4	1470	1770	90	0,83	52	175	6,6	2,4	2,8	0,180	205
33 40,5	38 46,5	225 S4 225 M4	1475 1475	1775 1775	92 92	0,83 0,83	62 77	213 262	6,7 6,7	2,4 2,4	2,8 2,8	0,320 0,410	302 332
50	57,5	250 M4	1475	1775	92	0,87	90	323	6,4	2,4	2,5	0,520	370
61 75	70 86	280 S4 280 M4	1485 1485	1780 1780	93,5 94	0,85 0,87	111 132	392 482	7,7 7,7	2,7 2,7	2,6 2,6	0,885 1,060	525 584
110 115 138 170	110 132 158 195	315 SM4 315 MA4 315 MC4 315 MD4	1486 1485 1485 1485	1790 1785 1785 1785	94 94 94 94	0,83 0,84 0,84 0,85	204 210 252 307	706 739 887 1092	6,9 6,5 6,5 6,8	2,8 2,6 2,6 2,7	2,8 2,6 2,6 2,6	2,100 2,100 2,500 3,100	780 780 859 965

I_s = Starting current, T_s = Starting torque, T_{MAX} = Breakdown torque.

Detailed data for 440V/60Hz on request.

The motors shown on this page are not multivoltage. Output values at 440V/60Hz refer to motors with dedicated winding.

RATED OUTPUT kW		MOTOR TYPE	PERFORMANCE AT RATED OUTPUT					PERFORMANCE AT RATED VOLTAGE					MOMENT OF INERTIA J kgm ²	WEIGHT IM 1001 Approx. kg
			SPEED		EFFICIENCY η %	POWER FACTOR cos φ	400V 50Hz							
			n 1/min				RATED CURRENT I A	RATED TORQUE T _n Nm	STARTING CURRENT I _s /I _n p.u.	STARTING TORQUE T _s /T _n p.u.	BREAKDOWN TORQUE T _{MAX} /T _n p.u.			
50 Hz	60 Hz		50 Hz	60 Hz										

1000/1200 min⁻¹ = 6 poles - 50/60 Hz

T5, T 100°C

0,37	0,37	80 MA6	930	1130	65,2	0,72	1,1	3,8	3,6	1,9	2,25	0,0024	21,3
0,55	0,55	80 MB6	930	1140	68,0	0,73	1,6	5,6	3,9	2,1	2,4	0,0028	23,3
0,75	0,75	90 S6	930	1120	71,1	0,73	2,1	7,7	4,6	2,1	2,3	0,0038	27,8
1,5	1,5	100 LA6	940	1140	75,3	0,75	3,8	15,2	5,1	2,0	2,3	0,0100	47,3
3,0	3,0	132 SA6	950	1150	80,1	0,76	7,1	30,2	5,5	2,1	2,4	0,0300	72,8
7,5	9	160 M6	965	1165	86	0,82	15,4	74	5,0	2,0	2,3	0,087	131
11	13	160 L6	975	1175	86,5	0,82	22,4	108	5,5	2,3	2,5	0,110	147
13,5	15,5	180 L6	975	1175	88	0,82	27	132	5,2	2,3	2,2	0,130	165
17,0	19,5	200 LA6	970	1170	88	0,83	33,6	167	5,5	2,2	2,3	0,170	185
20	23	200 LB6	975	1175	89	0,83	39,1	196	6,0	2,5	2,5	0,220	203
26	30	225 M6	980	1180	90	0,81	52	253	6,5	2,6	2,7	0,470	309
32	36,5	250 M6	975	1185	90	0,83	62	313	6,5	2,6	2,6	0,570	342
36	41,5	280 S6	988	1180	92	0,82	69	348	6,0	2,5	2,5	0,850	479
45	51,5	280 M6	988	1180	92	0,82	86	435	6,0	2,5	2,5	1,075	518
70	80	315 SM6	987	1185	94	0,83	130	677	6,9	2,9	2,9	2,600	748
75	86	315 MA6	985	1185	94	0,84	137	726	6,3	2,6	2,6	2,600	748
90	103	315 MB6	985	1185	94	0,84	165	872	6,3	2,6	2,6	3,000	799
105	120	315 MC6	985	1185	94	0,84	192	1017	6,6	2,6	2,6	3,600	889
128	147	315 MD6	985	1185	94	0,85	232	1240	6,6	2,8	2,6	4,400	994

750/900 min⁻¹ = 8 poles - 50/60 Hz

T5, T 100°C

0,18	0,18	80 MA8	660	820	53,0	0,72	0,7	2,6	3,5	2,0	1,8	0,0024	21,8
0,25	0,25	80 MB8	690	835	56,3	0,67	1,0	3,5	3,5	2,0	1,8	0,0028	22,8
0,37	0,37	90 S8	675	840	59,3	0,66	1,4	5,2	3,5	2,0	1,8	0,0038	27,3
0,55	0,55	90 L8	695	850	63,3	0,64	2,0	7,6	3,5	2,0	1,8	0,0050	35,8
0,75	0,75	100 LA8	680	865	70,5	0,69	2,2	10,5	4,0	2,1	2,0	0,0093	45,3
1,1	1,1	100 LB8	695	865	71,5	0,69	3,2	15,1	4,1	2,3	2,3	0,0123	50,3
2,2	2,2	132 SA8	710	860	75,0	0,74	5,7	29,6	4,4	2,0	2,2	0,0380	78,8
4,0	4,5	160 MA8	720	870	81	0,73	9,8	53	4,2	1,9	2,1	0,080	115
5,5	6,0	160 MB8	720	870	82	0,74	13,1	73	4,2	1,9	2,1	0,092	123
7,0	8,0	160 L8	725	875	83	0,73	16,7	92	4,2	2,0	2,1	0,110	133
10,0	12,0	180 L8	728	880	86	0,74	22,7	131	4,5	2,0	2,2	0,160	188
13,5	16,0	200 L8	728	880	87	0,75	29,9	177	5,0	2,1	2,3	0,220	216
17,0	19,5	225 S8	728	880	89	0,76	36,3	227	5,3	2,3	2,4	0,420	294
20,5	23,5	225 M8	730	880	90	0,74	44,5	268	5,7	2,4	2,5	0,520	326
28	32	250 M8	730	880	91	0,76	59	366	5,7	2,4	2,5	0,620	356
34	39	280 S8	737	885	92	0,79	68	433	6,0	2,5	2,7	1,050	520
41	47	280 M8	737	885	92	0,79	82	527	6,0	2,5	2,7	1,250	553
60	65	315 SM8	741	891	93	0,79	118	644	6,8	2,4	2,5	2,8	776
65	74,5	315 MA8	740	890	93,5	0,80	126	838	6,3	2,2	2,3	2,8	776
80	91,5	315 MC8	740	890	94	0,81	152	1031	6,5	2,3	2,4	3,5	886
95	109	315 MD8	740	890	94	0,81	180	1225	6,5	2,3	2,4	4,0	924
112	128	315 ME8	740	890	94	0,81	213	1444	6,5	2,3	2,4	4,3	993

I_s = Starting current, T_s = Starting torque, T_{MAX} = Breakdown torque.

Detailed data for 440V/60Hz on request.

The motors shown on this page are not multivoltage. Output values at 440V/60Hz refer to motors with dedicated winding.

MOTOR TYPE	SELF VENTILATED (IC 411)									FORCE VENTILATED (IC 416)					
	QUADRATIC TORQUE 5 ÷ 50			CONSTANT TORQUE 10 ÷ 50			CONSTANT TORQUE 10 ÷ 60			CONSTANT TORQUE 10 ÷ 50			CONSTANT TORQUE 10 ÷ 60		
	P _n [kW]	T _n [Nm]	I _n [A]	P _n [kW]	T _n [Nm]	I _n [A]	P _n [kW]	T _n [Nm]	I _n [A]	P _n [kW]	T _n [Nm]	I _n [A]	P _n [kW]	T _n [Nm]	I _n [A]

2 poles

71 MA2 ¹	0,37	1,29	0,99	0,26	0,91	0,69	0,26	0,91	0,69	-	-	-	-	-	-
71 MB2 ¹	0,55	1,92	1,39	0,39	1,35	0,97	0,39	1,35	0,97	-	-	-	-	-	-
80 MA2 ¹	0,75	2,6	1,76	0,53	1,79	1,23	0,53	1,79	1,23	-	-	-	-	-	-
80 MB2 ¹	1,1	3,7	2,4	0,77	2,6	1,71	0,77	2,6	1,71	-	-	-	-	-	-
90 S2 ¹	1,5	5,1	3,3	1,05	3,6	2,3	1,05	3,6	2,3	-	-	-	-	-	-
90 L2 ¹	2,2	7,4	4,7	1,54	5,2	3,3	1,54	5,2	3,3	-	-	-	-	-	-
100 LA2	2,9	9,5	6,0	1,89	6,2	3,9	1,89	6,2	3,9	-	-	-	-	-	-
112 M2	4	13,1	8,0	2,6	8,5	5,2	2,6	8,5	5,2	-	-	-	-	-	-
132 SA2	5,5	18,0	10,9	3,9	12,6	7,6	3,9	12,6	7,6	-	-	-	-	-	-
132 SB2	7,5	24,6	14,3	5,3	17,2	10,0	5,3	17,2	10,0	-	-	-	-	-	-
132 MB2	9	29,5	17,1	6,3	20,6	12,0	6,3	20,6	12,0	-	-	-	-	-	-
160 MA2	11	36	21,9	8,0	26,3	16,0	8,0	26,3	16,0	11	36	21,9	9,0	29,5	17,9
160 MB2	15	49	29,0	11,0	36	21,0	11,0	36	21,0	15	49	29,0	12,3	40	23,8
160 L2	18,5	60	37	12,2	40	24,0	12,2	40	24,0	18,5	60	37	15,2	49	30
180 M2	22	72	42	14,6	48	28,0	14,6	48	28,0	22	72	42	18,0	59	34
200 LA2	30	97	54	21,9	71	39	21,9	71	39	30	97	54	24,6	80	44
200 LB2	37	120	67	24,3	79	44	24,3	79	44	37	120	67	30	98	55
225 M2	45	145	80	33	106	58	33	106	58	45	145	80	37	119	65
250 M2	55	177	98	40	130	72	40	130	72	55	177	98	45	145	80
280 S2	75	242	133	50	160	88	50	160	88	75	242	133	61	198	109
280 M2	90	290	157	59	191	103	59	191	103	90	290	157	74	238	128
315 SM2	110	353	194	80	258	141	80	258	141	110	353	194	90	289	158
315 MA2	132	424	235	87	279	155	87	279	155	132	424	235	108	348	192
315 MC2	160	514	281	105	337	185	105	337	185	160	514	281	131	421	230
315 MD2	185	593	324	120	385	211	120	385	211	185	593	324	152	486	265
355 LX2	220	705	373	146	468	248	146	468	248	220	705	373	180	577	306
355 LW2	270	865	454	176	562	295	176	562	295	270	865	454	221	709	372
355 LY2	315	1009	522	205	656	339	205	656	339	315	1009	522	258	827	427
400 LX2	355	1138	596	231	739	387	231	739	387	355	1138	596	291	932	488
400 LW2	430	1378	718	280	896	467	280	896	467	430	1378	718	352	1129	588
400 LY2	530	1698	885	345	1104	575	345	1104	575	530	1698	885	434	1391	725

1: Not available with EEx de type of protection
 -: Not available

Table 1

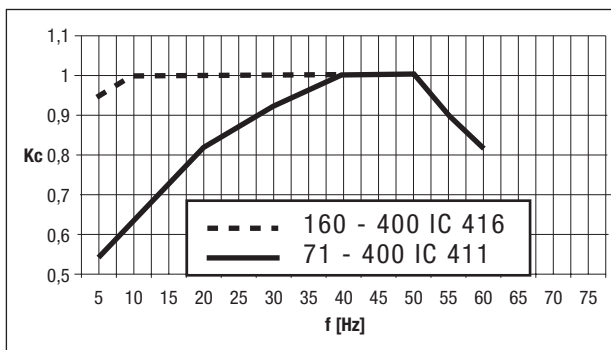

Curve 1: 2 poles - T3, T150°C

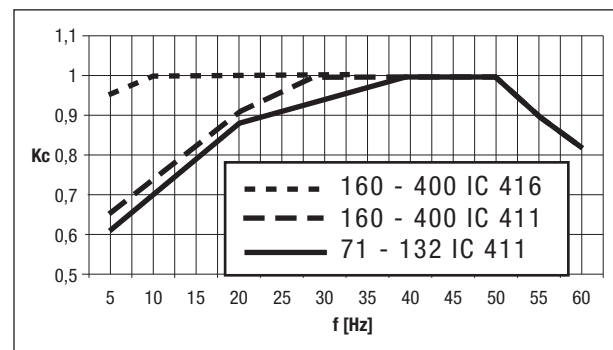

Curve 2: 2 poles - T4, T135°C

MOTOR TYPE	SELF VENTILATED (IC 411)									FORCE VENTILATED (IC 416)					
	QUADRATIC TORQUE 5 ÷ 50			CONSTANT TORQUE 10 ÷ 50			CONSTANT TORQUE 10 ÷ 60			CONSTANT TORQUE 10 ÷ 50			CONSTANT TORQUE 10 ÷ 60		
	P _n [kW]	T _n [Nm]	I _n [A]	P _n [kW]	T _n [Nm]	I _n [A]	P _n [kW]	T _n [Nm]	I _n [A]	P _n [kW]	T _n [Nm]	I _n [A]	P _n [kW]	T _n [Nm]	I _n [A]

2 poles

71 MA2 ¹	0,37	1,29	0,99	0,26	0,91	0,69	0,26	0,91	0,69	-	-	-	-	-	-
71 MB2 ¹	0,55	1,92	1,39	0,39	1,35	0,97	0,39	1,35	0,97	-	-	-	-	-	-
80 MA2 ¹	0,75	2,6	1,76	0,53	1,79	1,23	0,53	1,79	1,23	-	-	-	-	-	-
80 MB2 ¹	1,1	3,7	2,4	0,77	2,6	1,71	0,77	2,6	1,71	-	-	-	-	-	-
90 S2 ¹	1,5	5,1	3,3	1,05	3,6	2,3	1,05	3,6	2,3	-	-	-	-	-	-
90 L2 ¹	2,2	7,4	4,7	1,54	5,2	3,3	1,54	5,2	3,3	-	-	-	-	-	-
100 LA2	2,7	8,9	5,6	1,89	6,2	3,9	1,89	6,2	3,9	-	-	-	-	-	-
112 M2	3,6	11,8	7,2	2,5	8,3	5,1	2,5	8,3	5,1	-	-	-	-	-	-
132 SA2	5,5	18,0	10,9	3,9	12,6	7,6	3,9	12,6	7,6	-	-	-	-	-	-
132 SB2	7,5	24,6	14,3	5,3	17,2	10,0	5,3	17,2	10,0	-	-	-	-	-	-
132 MB2	9	29,5	17,1	6,3	20,6	12,0	6,3	20,6	12,0	-	-	-	-	-	-
160 MA2	11	36	21,9	8,0	26,3	16,0	8,0	26,3	16,0	11	36	21,9	9,0	29,5	17,9
160 MB2	15	49	29,0	11,0	36	21,0	11,0	36	21,0	15	49	29,0	12,3	40	23,8
160 L2	16,7	55	33	12,2	40	24,0	12,2	40	24,0	16,7	55	33	13,7	45	21,1
180 M2	20	65	38	14,6	48	28,0	14,6	48	28,0	20	65	38	16,4	53	31
200 LA2	30	97	54	21,9	71	39	21,9	71	39	30	97	54	24,6	80	44
200 LB2	33	108	60	24,3	79	44	24,3	79	44	33	108	60	27,3	89	49
225 M2	45	145	80	33	106	58	33	106	58	45	145	80	37	119	65
250 M2	55	177	98	40	130	72	40	130	72	55	177	98	45	145	80
280 S2	68	219	121	50	160	88	50	160	88	68	219	121	56	180	99
280 M2	81	261	141	59	191	103	59	191	103	81	261	141	66	214	116
315 SM2	110	353	194	80	258	141	80	258	141	110	353	194	90	290	159
315 MA2	119	383	212	87	279	155	87	279	155	119	383	212	98	314	174
315 MC2	144	462	253	105	337	185	105	337	185	144	462	253	118	379	208
315 MD2	160	513	280	117	385	211	120	385	211	160	513	280	131	420	230
355 LX2	200	641	339	146	468	248	146	468	248	200	641	339	164	526	278
355 LW2	230	737	387	168	538	282	168	538	282	230	737	387	189	604	317
355 LY2	250	801	414	183	585	302	183	585	302	250	801	414	205	657	339
400 LX2	315	1009	529	230	737	386	230	737	386	315	1009	529	258	828	434
400 LW2	380	1218	634	277	889	463	277	889	463	380	1218	634	312	999	520
400 LY2	450	1442	751	329	1053	548	329	1053	548	450	1442	751	369	1182	616

1: Not available with EEx de type of protection
 -: Not available

Table 2

In case of operating frequencies out from the ranges shown in the table above, please proceed as follow.

Quadratic torque

If f_{max} (maximum supply frequency) is ≤ 50 Hz and the minimum supply frequency f_{min} is ≥ 5 Hz, the available outputs remain those shown in tables 1 and 2 respectively for temperature class T3 (or maximum surface temperature T150°C) or T4 (T135°C).

Constant torque

- By applying to the curve 1 or 2 given in the previous page, and depending on the class of temperature or the maximum surface temperature, calculate the K_c value relate to frequency variation's limits, and take into consideration the lower only in case of IC411, or that one at the max frequency as for IC416.
- In order to get the T_m value (maximum torque of the motor), multiply the K_c value by the T_n value of the quadratic torque's column within the class of temperature and/or max surface temperature (table 1 or table 2).
- The following formulas are to be applied to calculate the nominal power P_n and current I_n at 400V 50Hz.

$$P'_n = P_n \times \frac{T_m}{T_n} \text{ [kW]} \quad I'_n = I_n \times \frac{T_m}{T_n} \text{ [A]}$$

MOTOR TYPE	SELF VENTILATED (IC 411)									FORCE VENTILATED (IC 416)					
	QUADRATIC TORQUE 5 ÷ 50			CONSTANT TORQUE 10 ÷ 50			CONSTANT TORQUE 10 ÷ 85			CONSTANT TORQUE 10 ÷ 50			CONSTANT TORQUE 10 ÷ 85		
	P _n [kW]	T _n [Nm]	I _n [A]	P _n [kW]	T _n [Nm]	I _n [A]	P _n [kW]	T _n [Nm]	I _n [A]	P _n [kW]	T _n [Nm]	I _n [A]	P _n [kW]	T _n [Nm]	I _n [A]

4 poles

71 MA4 ¹ 71 MB4 ¹	0,25 0,37	1,73 2,6	0,78 1,13	0,18 0,26	1,21 1,79	0,55 0,79	0,15 0,22	1,04 1,54	0,47 0,68	-	-	-	-	-	-
80 MA4 ¹ 80 MB4 ¹	0,55 0,75	3,8 5,2	1,49 2,0	0,39 0,53	2,7 3,6	1,04 1,40	0,33 0,45	2,30 3,1	0,89 1,20	-	-	-	-	-	-
90 S4 ¹ 90 L4 ¹	1,1 1,5	7,6 10,3	2,6 3,3	0,77 1,05	5,3 7,2	1,84 2,3	0,66 0,90	4,5 6,2	1,58 2,0	-	-	-	-	-	-
100 LA4 100 LB4	2,2 3	14,8 20,2	4,8 6,4	1,54 2,1	10,4 14,1	3,1 4,5	1,32 1,8	8,9 12,1	2,9 3,9	-	-	-	-	-	-
112 M4	4	26,8	8,3	2,8	18,8	5,8	2,4	16,1	5,0	-	-	-	-	-	-
132 SA4 132 MA4	5,5 7,5	36 49	11,3 14,7	3,9 5,3	25,5 35	7,9 10,3	3,3 4,5	21,9 29,6	6,8 8,8	-	-	-	-	-	-
160 M4 160 L4	11 15	72 98	22,1 29,9	8,0 9,9	53 64	16,2 20	6,6 8,1	43,0 53	13,3 16,1	11 15	72 98	22,1 29,9	6,6 9,0	43 59	13,3 17,9
180 M4 180 L4	17,6 22	115 143	34 42	12,2 16,1	80 105	24 31	10,0 13,2	66 86	19,6 25,1	17,6 22	115 143	34 42	10,6 13,2	69 86	20,7 25,1
200 L4	30	195	56	21,9	142	41	18,0	117	34	30	195	56	18,0	117	34
225 S4 225 M4	37 45	240 291	67 82	27,0 33	175 213	49 60	22,2 27,0	144 174	40 49	37 45	240 291	67 82	22,2 27,0	144 175	40 49
250 M4	55	356	98	37	236	65	30	194	54	55	356	98	33	214	59
280 S4 280 M4	75 90	484 581	134 157	55 66	353 424	98 115	45 54	290 348	81 94	75 90	484 581	134 157	45 54	290 348	81 94
315 SM4 315 MA4 315 MC4 315 MD4	110 132 160 185	706 849 1029 1190	200 237 287 326	73 96 105 120	468 620 676 773	132 173 188 212	60 79 86 111	385 509 556 714	109 142 155 195	110 132 160 185	706 849 1029 1190	200 237 287 326	66 79 96 111	424 509 617 714	120 142 172 195
355 LX4 355 LW4 355 LY4	240 285 315	1538 1827 2019	417 496 546	156 185 205	1000 1187 1312	271 322 355	144 171 189	923 1096 1211	250 297 328	240 285 315	1538 1827 2019	417 496 546	144 171 189	923 1096 1211	250 297 328
400 LX4 400 LW4 400 LY4	355 430 530	2275 2756 3397	610 739 910	231 280 345	1479 1791 2208	396 480 592	213 258 318	1365 1654 2038	366 443 546	355 430 530	2275 2756 3397	610 739 910	213 258 318	1365 1654 2038	366 443 546

1: Not available with EEx de type of protection
 -: Not available

Table 3

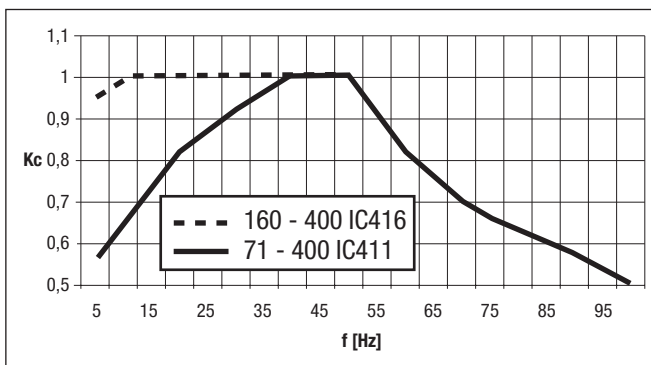

Curve 3: 4 poles - T3, T150°C

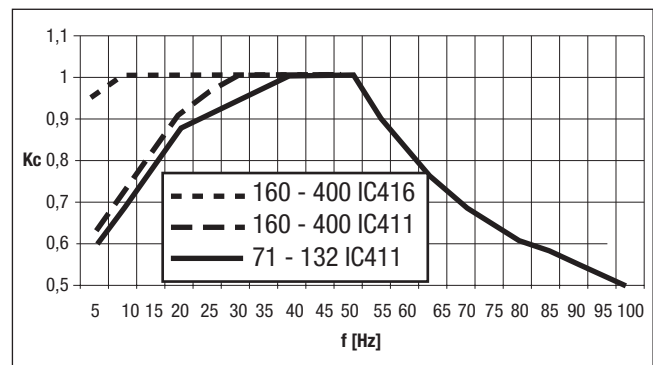

Curve 4: 4 poles - T4, T135°C

For maximum frequency between 75Hz and 100Hz, please contact MarelliMotori.

MOTOR TYPE	SELF VENTILATED (IC 411)									FORCE VENTILATED (IC 416)					
	QUADRATIC TORQUE 5 ÷ 50			CONSTANT TORQUE 10 ÷ 50			CONSTANT TORQUE 10 ÷ 85			CONSTANT TORQUE 10 ÷ 50			CONSTANT TORQUE 10 ÷ 85		
	P _n [kW]	T _n [Nm]	I _n [A]	P _n [kW]	T _n [Nm]	I _n [A]	P _n [kW]	T _n [Nm]	I _n [A]	P _n [kW]	T _n [Nm]	I _n [A]	P _n [kW]	T _n [Nm]	I _n [A]

4 poles

71 MA4 ¹	0,25	1,73	0,78	0,18	1,21	0,55	0,15	1,04	0,47	-	-	-	-	-	-
71 MB4 ¹	0,37	2,6	1,13	0,26	1,79	0,79	0,22	1,54	0,68	-	-	-	-	-	-
80 MA4 ¹	0,55	3,8	1,49	0,39	2,7	1,04	0,33	2,3	0,89	-	-	-	-	-	-
80 MB4 ¹	0,75	5,2	2,0	0,53	3,6	1,40	0,45	3,1	1,20	-	-	-	-	-	-
90 S4 ¹	1,1	7,6	2,6	0,77	5,3	1,84	0,66	4,5	1,58	-	-	-	-	-	-
90 L4 ¹	1,5	10,3	3,3	1,05	7,2	2,3	0,90	6,2	2,0	-	-	-	-	-	-
100 LA4	2,2	14,8	4,8	1,54	10,4	3,4	1,32	8,9	2,9	-	-	-	-	-	-
100 LB4	3	20,2	6,4	2,1	14,1	4,5	1,80	12,1	3,9	-	-	-	-	-	-
112 M4	4	26,8	8,3	2,8	18,8	5,8	2,4	16,1	5,0	-	-	-	-	-	-
132 SA4	5,5	36	11,3	3,9	25,5	7,9	3,3	21,9	6,8	-	-	-	-	-	-
132 MA4	7,5	49	14,7	5,3	35	10,3	4,5	29,6	8,8	-	-	-	-	-	-
160 M4	11	72	22,1	8,0	53	16,2	6,6	43	13,3	11	72	22,1	6,6	43	13,3
160 L4	13,5	88	26,9	9,9	64	20	8,1	53	16,1	13,5	88	26,9	8,1	53	16,1
180 M4	16,7	109	33	12,2	80	24	10,0	66	19,6	16,7	109	33	10,0	66	19,6
180 L4	22	143	42	16,1	105	31	13,2	86	25,1	22	143	42	13,2	86	25,1
200 L4	30	195	56	21,9	142	41	18,0	117	34	30	195	56	18,0	117	34
225 S4	37	240	67	27,0	175	49	22,2	144	40	37	240	67	22,2	144	40
225 M4	45	291	82	33	213	60	27,0	174	49	45	291	82	27,0	175	49
250 M4	50	324	89	37	236	65	30	194	54	50	324	89	30	194	54
280 S4	75	484	134	55	353	98	45	290	81	75	484	134	45	290	81
280 M4	90	581	157	66	424	115	54	348	94	90	581	157	54	348	94
315 SM4	110	706	200	73	468	132	60	385	109	110	706	200	60	385	109
315 MA4	132	849	237	96	620	173	79	509	142	132	849	237	79	509	142
315 MC4	144	926	258	105	676	188	86	556	155	144	926	258	86	556	155
315 MD4	160	1029	282	117	751	206	96	617	169	160	1029	282	96	617	169
355 LX4	200	1282	348	146	936	254	120	769	209	200	1282	348	120	769	209
355 LW4	250	1602	435	183	1170	317	150	961	261	250	1602	435	150	961	261
355 LY4	270	1730	468	197	1263	342	162	1038	281	270	1730	468	162	1038	281
400 LX4	315	2019	541	230	1474	395	189	1211	325	315	2019	541	189	1211	325
400 LW4	380	2435	653	277	1778	476	228	1461	392	380	2435	653	228	1461	392
400 LY4	450	2884	773	329	2105	564	270	1730	464	450	2884	773	270	1730	464

1: Not available with EEx de type of protection
 -: Not available

Table 4

In case of operating frequencies out from the ranges shown in the table above, please proceed as follow.

Quadratic torque

If f_{max} (maximum supply frequency) is ≤ 50 Hz and the minimum supply frequency f_{min} is ≥ 5 Hz, the available outputs remain those shown in tables 3 and 4 respectively for temperature class T3 (or maximum surface temperature T150°C) or T4 (T135°C).

Constant torque

- By applying to the curve 3 or 4 given in the previous page, and depending on the class of temperature or the maximum surface temperature, calculate the K_c value relate to frequency variation's limits, and take into consideration the lower only in case of IC411, or that one at the max frequency as for IC416.
- In order to get the T_m value (maximum torque of the motor), multiply the K_c value by the T_n value of the quadratic torque's column within the class of temperature and/or max surface temperature (table 3 or table 4).
- The following formulas are to be applied to calculate the nominal power P_n and current I_n at 400V 50Hz.

$$P'_n = P_n \times \frac{T_m}{T_n} \text{ [kW]} \quad I'_n = I_n \times \frac{T_m}{T_n} \text{ [A]}$$

MOTOR TYPE	SELF VENTILATED (IC 411)									FORCE VENTILATED (IC 416)					
	QUADRATIC TORQUE 5 ÷ 50			CONSTANT TORQUE 10 ÷ 50			CONSTANT TORQUE 10 ÷ 85			CONSTANT TORQUE 10 ÷ 50			CONSTANT TORQUE 10 ÷ 85		
	P _n [kW]	T _n [Nm]	I _n [A]	P _n [kW]	T _n [Nm]	I _n [A]	P _n [kW]	T _n [Nm]	I _n [A]	P _n [kW]	T _n [Nm]	I _n [A]	P _n [kW]	T _n [Nm]	I _n [A]

6 poles

80 MA6 ¹	0,37	3,8	1,14	0,26	2,7	0,80	0,22	2,3	0,68	-	-	-	-	-	-
80 MB6 ¹	0,55	5,6	1,60	0,39	4,0	1,12	0,33	3,4	0,96	-	-	-	-	-	-
90 S6 ¹	0,75	7,7	2,1	0,53	5,4	1,46	0,45	4,6	1,25	-	-	-	-	-	-
90 L6 ¹	1,1	11,3	3,0	0,77	7,9	2,1	0,66	6,8	1,80	-	-	-	-	-	-
100 LA6	1,5	15,2	3,8	1,05	10,7	2,7	0,90	9,1	2,3	-	-	-	-	-	-
112 M6	2,2	22,3	5,4	1,54	15,6	3,8	1,32	13,4	3,2	-	-	-	-	-	-
132 SA6	3	30	7,1	1,89	19,0	4,5	1,80	18,1	4,3	-	-	-	-	-	-
132 MA6	3,8	38	8,7	2,5	25,3	5,8	2,3	22,9	5,2	-	-	-	-	-	-
132 MB6	5,2	52	11,7	3,5	35	7,9	3,1	31	7,0	-	-	-	-	-	-
160 M6	7,5	71	15,4	5,5	54	11,2	4,5	45	9,2	7,5	71	15,4	4,5	45	9,2
160 L6	11	109	22,0	8,0	79	16,1	6,6	65	13,2	11	109	22,0	6,6	65	13,2
180 L6	15	148	29,9	11,0	108	21,9	9,0	89	18,0	15	148	29,9	9,0	89	18,0
200 LA6	18,5	182	36	13,1	129	25,9	11,1	109	21,9	18,5	182	36,0	11,1	109	21,9
200 LB6	22	216	43	14,6	143	28,5	13,2	130	25,8	22	216	43	13,2	130	25,8
225 M6	30	294	57	21,9	214	42	18,0	176	34	30	294	57	18,0	176	34,0
250 M6	37	362	70	27,0	265	51	22,2	217	42	37	362	70	22,2	217	42
280 S6	45	438	85	33	320	62	27,0	263	51	45	438	85	27,0	263	51
280 M6	55	536	102	40	391	74	33	322	61	55	536	102	33,0	322	61
315 SM6	71	688	131	49	474	90	43	413	79	71	688	131	43	413	79
315 MA6	90	873	165	66	637	120	54	524	99	90	873	165	54	524	99
315 MB6	110	1066	201	80	778	147	66	640	121	110	1066	201	66	640	121
315 MC6	132	1280	240	96	934	175	79	768	144	132	1280	240	79	768	144
315 MD6	152	1474	269	105	1019	186	91	884	161	152	1474	269	91	884	161
355 LX6	190	1833	336	124	1191	218	114	1100	201	190	1833	336	114	1100	201
355 LW6	240	2315	424	156	1505	276	144	1389	254	240	2315	424	144	1389	254
355 LY6	270	2604	477	176	1693	310	162	1563	286	270	2604	477	162	1563	286
400 LX6	300	2879	524	195	1871	341	180	1728	314	300	2879	524	180	1728	314
400 LW6	340	3263	594	221	2121	386	204	1958	356	340	3263	594	204	1958	356
400 LY6	380	3647	664	247	2371	431	228	2188	398	380	3647	664	228	2188	398

1: Not available with EEx de type of protection
 -: Not available

Table 5

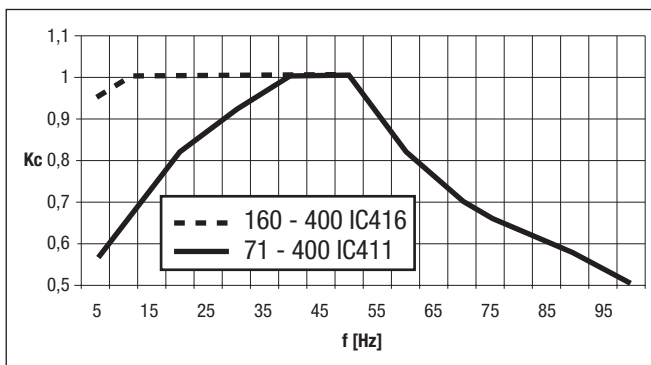

Curve 5: 6 poles - T3, T150°C

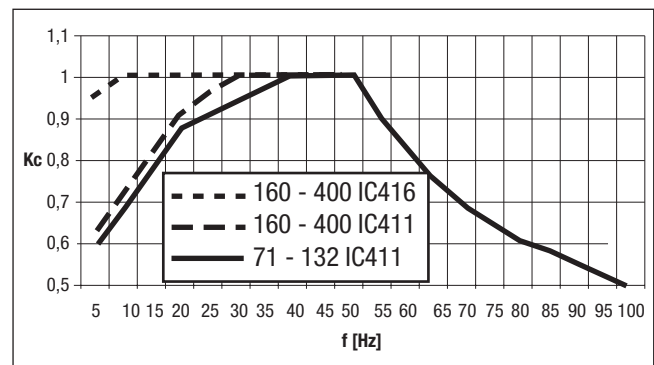

Curve 6: 6 poles - T4, T135°C

For maximum frequency between 75Hz and 100Hz, please contact MarelliMotori.

MOTOR TYPE	SELF VENTILATED (IC 411)									FORCE VENTILATED (IC 416)					
	QUADRATIC TORQUE 5 ÷ 50			CONSTANT TORQUE 10 ÷ 50			CONSTANT TORQUE 10 ÷ 85			CONSTANT TORQUE 10 ÷ 50			CONSTANT TORQUE 10 ÷ 85		
	P _n [kW]	T _n [Nm]	I _n [A]	P _n [kW]	T _n [Nm]	I _n [A]	P _n [kW]	T _n [Nm]	I _n [A]	P _n [kW]	T _n [Nm]	I _n [A]	P _n [kW]	T _n [Nm]	I _n [A]

6 poles

80 MA6 ¹	0,37	3,8	1,14	0,26	2,7	0,80	0,22	2,3	0,68	-	-	-	-	-	-
80 MB6 ¹	0,55	5,6	1,60	0,39	4,0	1,12	0,33	3,4	0,96	-	-	-	-	-	-
90 S6 ¹	0,75	7,7	2,1	0,53	5,4	1,46	0,45	4,6	1,25	-	-	-	-	-	-
90 L6 ¹	1,1	11,3	3,0	0,77	7,9	2,1	0,66	6,8	1,80	-	-	-	-	-	-
100 LA6	1,5	15,2	3,8	1,05	10,7	2,7	0,90	9,1	2,3	-	-	-	-	-	-
112 M6	2,2	22,3	5,4	1,54	15,6	3,8	1,32	13,4	3,2	-	-	-	-	-	-
132 SA6	2,7	27,0	6,4	1,89	19,0	4,5	1,62	16,3	3,8	-	-	-	-	-	-
132 MA6	3,6	36	8,2	2,5	25,3	5,8	2,2	21,7	4,9	-	-	-	-	-	-
132 MB6	5	50	11,3	3,5	35	7,9	3,0	30	6,8	-	-	-	-	-	-
160 M6	7,5	71	15,4	5,5	54	11,2	4,5	45	9,2	7,5	71	15,4	4,5	45	9,2
160 L6	11	109	22,0	8,0	79	16,1	6,6	65	13,2	11	109	22,0	6,6	65	13,2
180 L6	15	148	29,9	11,0	108	21,9	9,0	89	18,0	15	148	29,9	9,0	89	18,0
200 LA6	18	177	35	13,1	129	25,9	10,8	106	21,3	18	177	35	10,8	106	21,3
200 LB6	20	196	39	14,6	143	28,5	12,0	118	23,4	20	196	39	12,0	118	23,4
225 M6	30	294	57	21,9	214	42	18,0	176	34	30	294	57	18,0	176	34
250 M6	37	362	70	27,0	265	51	22,2	217	42	37	362	70	22,2	217	42
280 S6	45	438	85	33	320	62	27,0	263	51	45	438	85	27,0	263	51
280 M6	55	536	102	40	391	74	33	322	61	55	536	102	33	322	61
315 SM6	67	650	124	49	474	90	40	390	74	67	650	124	40	390	74
315 MA6	90	873	165	66	637	120	54	524	99	90	873	165	54	524	99
315 MB6	110	1066	201	80	778	147	66	640	121	110	1066	201	66	640	121
315 MC6	132	1280	240	96	934	175	79	768	144	132	1280	240	79	768	144
315 MD6	144	1396	255	105	1019	186	86	838	153	144	1396	255	86	838	153
355 LX6	160	1543	283	117	1127	206	96	926	160	160	1543	283	96	926	160
355 LW6	210	2026	371	153	1479	271	126	1215	210	210	2026	371	126	1215	210
355 LY6	230	2219	406	168	1620	297	138	1331	230	230	2219	406	138	1331	230
400 LX6	250	2399	437	183	1752	319	150	1440	250	250	2399	437	150	1440	250
400 LW6	280	2687	489	204	1962	357	168	1612	280	280	2687	489	168	1612	280
400 LY6	315	3023	550	230	2207	402	189	1814	315	315	3023	550	189	1814	315

1: Not available with EEx de type of protection
 -: Not available

Table 6

In case of operating frequencies out from the ranges shown in the table above, please proceed as follow.

Quadratic torque

If f_{max} (maximum supply frequency) is ≤ 50 Hz and the minimum supply frequency f_{min} is ≥ 5 Hz, the available outputs remain those shown in tables 5 and 6 respectively for temperature class T3 (or maximum surface temperature T150°C) or T4 (T135°C).

Constant torque

- By applying to the curve 5 or 6 given in the previous page, and depending on the class of temperature or the maximum surface temperature, calculate the K_c value relate to frequency variation's limits, and take into consideration the lower only in case of IC411, or that one at the max frequency as for IC416.
- In order to get the T_m value (maximum torque of the motor), multiply the K_c value by the T_n value of the quadratic torque's column within the class of temperature and/or max surface temperature (table 5 or table 6).
- The following formulas are to be applied to calculate the nominal power P_n and current I_n at 400V 50Hz.

$$P'_n = P_n \times \frac{T_m}{T_n} \text{ [kW]} \quad I'_n = I_n \times \frac{T_m}{T_n} \text{ [A]}$$

MOTOR TYPE	SELF VENTILATED (IC 411)									FORCE VENTILATED (IC 416)					
	QUADRATIC TORQUE 5 ÷ 50			CONSTANT TORQUE 10 ÷ 50			CONSTANT TORQUE 10 ÷ 85			CONSTANT TORQUE 10 ÷ 50			CONSTANT TORQUE 10 ÷ 85		
	P _n [kW]	T _n [Nm]	I _n [A]	P _n [kW]	T _n [Nm]	I _n [A]	P _n [kW]	T _n [Nm]	I _n [A]	P _n [kW]	T _n [Nm]	I _n [A]	P _n [kW]	T _n [Nm]	I _n [A]

8 poles

80 MA8 ¹	0,18	2,6	0,68	0,13	1,82	0,48	0,11	1,56	0,41	-	-	-	-	-	-
80 MB8 ¹	0,25	3,5	0,96	0,18	2,4	0,67	0,15	2,1	0,57	-	-	-	-	-	-
90 S8 ¹	0,37	5,2	1,36	0,26	3,7	0,96	0,22	3,1	0,82	-	-	-	-	-	-
90 L8 ¹	0,55	7,6	2,0	0,39	5,3	1,37	0,33	4,5	1,18	-	-	-	-	-	-
100 LA8	0,75	10,5	2,2	0,53	7,4	1,56	0,45	6,3	1,34	-	-	-	-	-	-
100 LB8	1,1	15,1	3,2	0,77	10,6	2,3	0,66	9,1	1,93	-	-	-	-	-	-
112 M8	1,4	19,1	4,0	0,95	12,9	2,7	0,81	11,0	2,4	-	-	-	-	-	-
132 SA8	2,2	29,6	5,7	1,54	20,7	4,0	1,32	17,8	3,4	-	-	-	-	-	-
132 MA8	3	41	7,4	2,1	28,5	5,2	1,80	24,4	4,4	-	-	-	-	-	-
160 MA8	4	54	9,7	2,9	39	7,1	2,4	32	5,8	4	54	9,7	2,4	32	5,8
160 MB8	5,5	73	13,0	4,0	53	9,5	3,3	44	7,8	5,5	73	13,0	3,3	44	7,8
160 L8	7,5	99	17,3	5,5	73	12,6	4,5	60	10,4	7,5	99	17,3	4,5	60	10,4
180 L8	11	145	24,4	8,0	106	18	6,6	87	14,7	11	145	24,4	6,6	87	14,7
200 L8	15	198	33	11,0	144	24	9,0	119	19,7	15	198	33	9,0	119	19,7
225 M8	18,5	242	39	13,1	172	28	10,8	141	23,7	18,5	242	39	10,8	141	23,7
225 L8	22	288	46	16,1	210	34	13,2	173	27,9	22	288	46	13,2	173	27,9
250 M8	30	392	63	21,9	286	46	18,0	235	38	30	392	63	18,0	235	38
280 S8	37	481	72	27,0	351	53	22,2	288	43	37	481	72	22,2	288	43
280 M8	45	585	87	33	427	64	27,0	351	52	45	585	87	27,0	351	52
315 SM8	55	710	105	40	518	77	33	426	63	55	710	105	33	426	63
315 MA8	83	1071	156	55	707	103	45	581	93	83	1071	156	45	581	93
315 MC8	96	1239	177	66	848	121	54	697	106	96	1239	177	54	697	106
315 MD8	110	1419	202	80	1036	148	66	852	121	110	1419	202	66	852	121
315 ME8	132	1703	243	88	1130	161	72	929	146	132	1703	243	72	929	146
355 LX8	160	2065	290	110	1413	198	90	1161	174	160	2065	290	90	1161	174
355 LW8	200	2570	361	130	1671	234	102	1311	216	200	2570	361	102	1311	216
355 LY8	220	2824	395	143	1835	257	114	1463	237	220	2824	395	114	1463	237
400 LX8	240	3076	453	156	2000	294	120	1538	272	240	3076	453	120	1538	272
400 LW8	270	3461	510	176	2250	332	138	1769	306	270	3461	510	138	1769	306
400 LY8	300	3845	566	195	2499	368	150	1923	340	300	3845	566	150	1923	340

1: Not available with EEx de type of protection
 -: Not available

Table 7

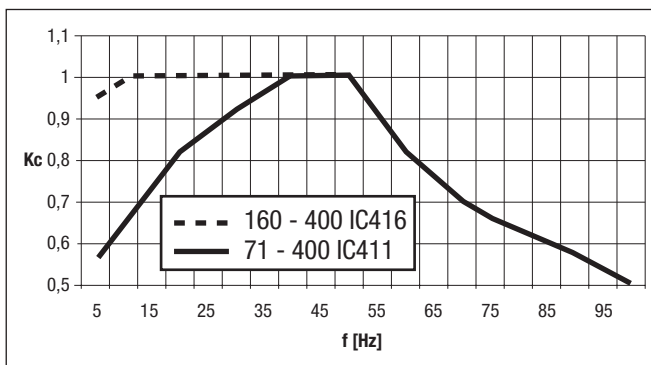

Curve 7: 8 poles - T3, T150°C

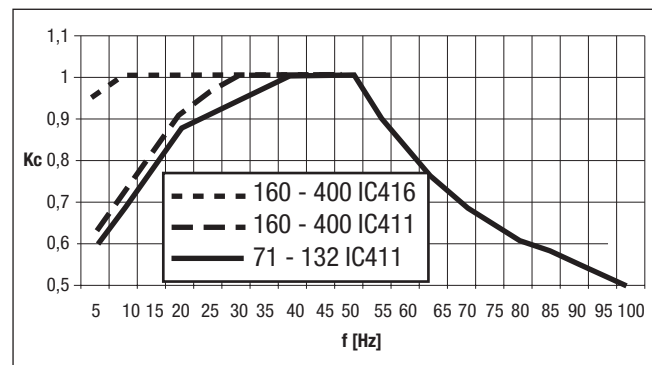

Curve 8: 8 poles - T4, T135°C

For maximum frequency between 75Hz and 100Hz, please contact MarelliMotori.

MOTOR TYPE	SELF VENTILATED (IC 411)									FORCE VENTILATED (IC 416)					
	QUADRATIC TORQUE 5 ÷ 50			CONSTANT TORQUE 10 ÷ 50			CONSTANT TORQUE 10 ÷ 85			CONSTANT TORQUE 10 ÷ 50			CONSTANT TORQUE 10 ÷ 85		
	P _n [kW]	T _n [Nm]	I _n [A]	P _n [kW]	T _n [Nm]	I _n [A]	P _n [kW]	T _n [Nm]	I _n [A]	P _n [kW]	T _n [Nm]	I _n [A]	P _n [kW]	T _n [Nm]	I _n [A]

8 poles

80 MA8 ¹	0,18	2,6	0,68	0,13	1,82	0,48	0,11	1,56	0,41	-	-	-	-	-	-
80 MB8 ¹	0,25	3,5	0,96	0,18	2,4	0,67	0,15	2,1	0,57	-	-	-	-	-	-
90 S8 ¹	0,37	5,2	1,36	0,26	3,7	0,96	0,22	3,1	0,82	-	-	-	-	-	-
90 L8 ¹	0,55	7,6	2,0	0,39	5,3	1,37	0,33	4,5	1,18	-	-	-	-	-	-
100 LA8	0,75	10,5	2,2	0,53	7,4	1,56	0,45	6,3	1,3	-	-	-	-	-	-
100 LB8	1,1	15,1	3,2	0,77	10,6	2,3	0,66	9,1	1,9	-	-	-	-	-	-
112 M8	1,35	18,4	3,8	0,95	12,9	2,7	0,81	11,0	2,4	-	-	-	-	-	-
132 SA8	2,2	29,6	5,7	1,54	20,7	4,0	1,32	17,8	3,4	-	-	-	-	-	-
132 MA8	3	41	7,4	2,1	28,5	5,2	1,80	24,4	4,4	-	-	-	-	-	-
160 MA8	4	54	9,7	2,9	39	7,1	2,4	32	5,8	4	54	9,7	2,4	32	5,8
160 MB8	5,5	73	13,0	4,0	53	9,5	3,3	44	7,8	5,5	73	13,0	3,3	44	7,8
160 L8	7,5	99	17,3	5,5	73	12,6	4,5	60	10,4	7,5	99	17,3	4,5	60	10,4
180 L8	11	145	24,4	8,0	106	17,8	6,6	87	14,7	11	145	24,4	6,6	87	14,7
200 L8	15	198	33	11,0	144	23,9	9,0	119	19,7	15	198	33	9,0	119	19,7
225 M8	18	235	38	13,1	172	28,0	10,8	141	23,7	18	235	38	10,8	141	23,7
225 L8	22	288	46	16,1	210	34	13,2	173	27,9	22	288	46	13,2	173	27,9
250 M8	30	392	63	21,9	286	46	18,0	235	38	30	392	63	18,0	235	38
280 S8	37	481	72	27,0	351	53	22,2	288	43	37	481	72	22,2	288	43
280 M8	45	585	87	33	427	64	27,0	351	52	45	585	87	27	351	52
315 SM8	55	710	105	40	518	77	33	426	63	55	710	105	33	426	63
315 MA8	75	968	141	55	707	103	45	581	93	75	968	141	45	581	93
315 MC8	90	1161	166	66	848	121	54	697	106	90	1161	166	54	697	106
315 MD8	110	1419	202	80	1036	148	66	852	121	110	1419	202	66	852	121
315 ME8	120	1549	221	88	1130	161	72	929	146	120	1549	221	72	929	146
355 LX8	150	1936	272	110	1413	198	90	1161	163	150	1936	272	90	1161	163
355 LW8	170	2185	307	124	1595	224	102	1311	184	170	2185	307	102	1311	184
355 LY8	190	2439	342	139	1780	249	114	1463	205	190	2439	342	114	1463	205
400 LX8	200	2564	377	146	1871	276	120	1538	226	200	2564	377	120	1538	226
400 LW8	230	2948	435	168	2152	317	138	1769	261	230	2948	435	138	1769	261
400 LY8	250	3204	472	183	2339	344	150	1923	283	250	3204	472	150	1923	283

1: Not available with EEx de type of protection
 -: Not available

Table 8

In case of operating frequencies out from the ranges shown in the table above, please proceed as follow.

Quadratic torque

If f_{max} (maximum supply frequency) is ≤50Hz and the minimum supply frequency f_{min} is ≥5Hz, the available outputs remain those shown in tables 7 and 8 respectively for temperature class T3 (or maximum surface temperature T150°C) or T4 (T135°C).

Constant torque

- By applying to the curve 7 or 8 given in the previous page, and depending on the class of temperature or the maximum surface temperature, calculate the K_c value relate to frequency variation's limits, and take into consideration the lower only in case of IC411, or that one at the max frequency as for IC416.
- In order to get the T_m value (maximum torque of the motor), multiply the K_c value by the T_n value of the quadratic torque's column within the class of temperature and/or max surface temperature (table 7 or table 8).
- The following formulas are to be applied to calculate the nominal power P_n and current I_n at 400V 50Hz.

$$P'_n = P_n \times \frac{T_m}{T_n} \text{ [kW]} \quad I'_n = I_n \times \frac{T_m}{T_n} \text{ [A]}$$

OUTPUT kW	MOTOR TYPE	PERFORMANCE AT RATED OUTPUT				DATA AT RATED VOLTAGE				MOMENT OF INERTIA J kgm ²	WEIGHT (IM 1001) Approx. kg
		SPEED n min ⁻¹	RATED CURRENT (400 V) I A		STARTING CURRENT Is/In p.u.	STARTING TORQUE Ts/Tn p.u.					

2 / 4 poles = 3000 / 1500 min⁻¹ - 50 Hz - single winding YY / Δ connection

T1 ÷ T3, T 150°C

0,31 0,44	0,20 0,29	71 MA 71 MB	2600 2640	1340 1360	0,86 1,19	0,60 0,84	3,2 3,8	3,0 3,2	1,9 2,4	2,0 2,6	0,0005 0,0006	16,3 17,3
0,62 0,85	0,42 0,59	80 MA 80 MB	2600 2710	1370 1380	1,69 2,38	1,19 1,48	3,5 3,3	3,4 3,8	2,5 2,6	2,1 2,3	0,0013 0,0016	21,3 22,8
1,18 1,55	0,92 1,25	90 S 90 L	2730 2780	1380 1390	2,95 3,8	2,17 2,85	3,6 4,2	3,9 4,4	2,5 2,9	2,4 2,6	0,0033 0,0040	27,3 31,8
2,05 3,1	1,45 2,4	100 LA 100 LB	2810 2850	1400 1405	4,8 7,1	3,4 5,4	4,5 5,0	4,6 4,6	2,4 2,5	2,2 2,2	0,0073 0,0090	45 50
4,4	3,5	112 M	2985	1435	9,7	7,7	6	6	3,0	3,0	0,0115	60
5 7	4 5,6	132 SA 132 MA	2910 2915	1465 1475	10,5 15,2	8,3 11,4	6,6 7,3	6,6 6,9	2,5 2,5	2,3 2,5	0,0238 0,0300	80 90
11 14	9 12	160 M 160 L	2880 2890	1450 1460	22,8 27,6	18,5 23,8	5,5 6,0	5,5 6,0	1,8 2,0	2,0 2,3	0,062 0,075	130 145
18,5 22 25	16 18,5 21	180 M 180 LA 180 LB	2900 2920 2920	1460 1460 1465	36,1 42,8 48,5	31,4 35,2 40,0	6,0 6,5 6,5	6,0 6,0 6,0	2,0 2,2 2,2	2,3 2,2 2,2	0,090 0,110 0,150	170 190 200
30 37 45	26 31 37	200 L 225 S 225 M	2920 2930 2930	1465 1465 1470	58 68 82	49 56 67	7,0 7,5 7,5	6,5 6,5 6,5	2,2 2,2 2,2	2,0 2,2 2,2	0,190 0,370 0,400	215 300 320
55 70 80	45 59 70	250 M 280 S 280 M	2930 2940 2940	1470 1470 1470	100 124 143	81 105 124	7,5 7,0 7,2	6,5 6,3 6,5	2,2 2,0 2,0	2,2 2,2 2,2	0,500 0,910 1,050	345 533 598
95 110 130 160	80 95 110 132	315 SM 315 MA 315 MC 315 MD	2940 2945 2945 2945	1470 1475 1475 1475	171 193 223 276	147 167 190 228	7,2 7,5 7,5 7,5	6,5 6,5 6,8 6,8	2,0 2,2 2,2 2,2	2,2 2,4 2,4 2,4	1,15 2,10 2,50 3,10	605 785 860 965

4 / 6 poles = 1500 / 1000 min⁻¹ - 50 Hz - single winding YY / Δ connection

T1 ÷ T3, T 150°C

0,43 0,62	0,31 0,45	80 MA 80 MB	1400 1410	920 930	1,62 1,90	1,25 1,52	3,4 3,5	3,1 3,2	1,75 1,8	2,3 2,5	0,0024 0,0027	21,3 23,3
0,88 1,32	0,66 0,95	90 S 90 L	1415 1420	930 940	2,66 3,90	2,09 2,90	3,8 4,8	3,3 4,0	1,8 2,0	2,4 2,5	0,0037 0,0050	27,8 34,3
1,75 2,2	1,0 1,4	100 LA 100 LB	1420 1420	940 945	4,5 5,3	3,5 4,7	4,5 4,8	4,1 3,7	1,5 1,7	2,3 2,4	0,0073 0,0090	45 50
2,8	1,85	112 M	1430	945	6,5	6,2	5,5	4,3	2,0	2,7	0,0115	60
4,0 5,3	2,9 3,7	132 SA 132 MA	1440 1445	950 960	9,1 11,8	8,6 10,5	6,7 7,5	5,3 5,5	2,1 2,2	2,4 2,6	0,0238 0,0300	80 90

4 / 6 poles = 1500 / 1000 min⁻¹ - 50 Hz - two separate windings

T1 ÷ T3, T 150°C

6,6 8,8	4,4 6	160 M 160 L	1470 1475	965 970	12,8 17,1	9,0 12,4	6,0 6,5	5,0 5,5	1,9 2,2	2,0 2,2	0,063 0,075	135 145
11 13 15	7,5 9 10	180 M 180 LA 180 LB	1475 1475 1475	970 970 970	20,9 24,7 28,5	15,2 18,1 20,0	6,8 7,0 7,0	5,8 6,5 6,5	2,2 2,2 2,0	2,2 2,2 2,2	0,090 0,160 0,220	165 190 195
18,5	12,5	200 L	1475	970	35	25	7,0	6,5	2,0	2,2	0,270	215
25 30	16 20	225 S 225 M	1475 1475	970 970	43 52	28 36	6,5 7,0	6,5 7,0	2,0 2,0	2,2 2,2	0,420 0,520	390 315
40	27	250 M	1480	975	73	50	7,0	7,0	2,0	2,2	0,670	360
51 63	34 42	280 S 280 M	1480 1480	980 980	93 114	62 76	6,5 6,5	6,0 6,0	2,0 2,0	2,2 2,2	1,050 1,250	483 523
70 85 103 118 140	47 55 70 80 90	315 SM 315 MA 315 MB 315 MC 315 MD	1480 1480 1480 1480 1480	980 980 980 980 980	124 147 181 209 247	86 100 124 143 162	6,5 6,5 6,5 6,5 6,5	6,2 6,0 6,0 6,0 6,0	2,0 1,6 1,8 1,8 1,8	2,2 2,0 2,0 2,0 2,0	1,43 2,60 3,00 3,60 4,45	575 755 805 900 1000

Is = Starting current; Ts = Starting torque.

The motors shown on this page are not multivoltage.

OUTPUT kW	MOTOR TYPE	PERFORMANCE AT RATED OUTPUT				DATA AT RATED VOLTAGE				MOMENT OF INERTIA J kgm ²	WEIGHT (IM 1001) Approx. kg
		SPEED n min ⁻¹	RATED CURRENT (400 V) I A	STARTING CURRENT Is/In p.u.	STARTING TORQUE Ts/Tn p.u.						

4 / 8 poles = 1500 / 750 min⁻¹ - 50 Hz - single winding YY / Δ connection

T1 ÷ T3, T 150°C

0,35	0,18	80 MA	1270	710	1,19	0,83	2,8	2,3	1,3	1,6	0,0024	21
0,62	0,31	80 MB	1300	690	1,66	1,45	3,5	2,7	1,7	2,1	0,0027	23
0,92	0,42	90 L	1300	665	2,04	1,71	3,5	2,3	1,9	2,4	0,0040	32
1,22	0,60	100 LA	1380	705	2,85	2,09	4,4	3,7	1,9	2,2	0,0093	47
1,9	0,95	100 LB	1410	705	4,6	3,3	4,8	3,8	2,0	2,4	0,012	50
2,4	1,2	112 M	1420	700	5,5	4,2	5,5	4,1	2,0	2,5	0,017	60
3,7	2,1	123 SA	1420	705	8,6	6,5	6,0	4,1	2,8	2,2	0,038	80
4,6	2,6	132 MA	1430	705	10,1	8,1	6,0	4,2	2,5	2,2	0,046	95
7	4	160 MA	1460	710	13,3	10,0	6,0	4,5	1,8	1,8	0,087	130
8	5	160 MB	1460	715	15,2	12,4	6,0	4,5	1,8	1,8	0,093	135
11	6,5	160 L	1460	725	21	16,2	6,0	4,5	1,8	1,8	0,110	145
15	9	180 LA	1465	730	29	21	6,0	5,0	2,0	2,0	0,160	190
18,5	11	180 LB	1465	730	36	25	6,0	5,0	2,0	2,0	0,220	195
21	13	200 L	1465	735	41	29	6,5	6,0	2,0	2,2	0,270	215
23	15	225 S	1470	735	44	33	7,0	6,0	2,2	2,2	0,420	390
32	22	225 M	1470	735	57	49	7,0	6,0	2,2	2,2	0,570	315
40	26	250 M	1470	735	71	57	7,0	6,0	2,2	2,2	0,620	360
51	31	280 S	1475	740	90	67	6,5	5,5	2,0	2,0	1,05	523
63	37	280 M	1475	740	107	78	6,5	5,5	2,0	2,0	1,25	553
66	45	315 SM	1480	735	114	95	6,8	5,7	2,0	2,2	1,37	605
80	52	315 MA	1480	740	140	105	6,5	5,5	2,0	2,0	2,62	755
95	63	315 MB	1480	740	163	125	6,5	5,5	2,0	2,0	3,00	805
110	75	315 MC	1480	740	185	147	6,5	5,5	2,0	2,0	3,60	895
132	88	315 MD	1480	740	223	171	6,5	5,5	2,0	2,0	4,40	1000

6 / 8 poles = 1000 / 750 min⁻¹ - 50 Hz - two separate windings

T1 ÷ T3, T 150°C

3,7	2,6	160 MA	965	710	7,6	5,7	5,5	4,5	1,7	1,7	0,087	130
4,4	3,3	160 MB	965	715	9,0	7,3	6,0	4,8	1,8	1,7	0,092	135
6	4,4	160 L	970	725	11,9	9,5	6,0	5,0	1,8	1,8	0,110	145
7,5	5,5	180 LA	970	730	14,3	11,9	6,0	5,0	1,8	1,8	0,160	190
9	6,5	180 LB	970	730	17,1	13,8	6,0	5,0	1,8	1,8	0,220	195
10,5	8	200 L	970	735	20	17	6,0	5,8	1,8	1,8	0,270	215
15	11	225 S	975	735	28	23	6,0	6,0	1,8	1,8	0,420	290
19	15	225 M	975	735	35	20	6,0	6,0	1,8	1,8	0,520	315
25	18,5	250 M	975	735	51	41	6,0	6,0	1,8	1,8	0,670	360
35	26	280 S	975	740	65	51	6,0	5,5	1,8	1,8	1,050	523
43	32	280 M	975	740	78	62	6,0	5,5	1,8	1,8	1,250	553
48	37	315 SM	980	740	87	71	6,0	5,5	1,8	1,8	2,81	605
60	45	315 MA	980	740	109	87	6,0	5,5	1,8	1,8	2,62	755
70	52	315 MB	980	740	128	100	6,0	5,5	1,8	1,8	3,00	805
77	60	315 MC	980	740	141	114	6,0	5,5	1,8	1,8	3,60	900
100	75	315 MD	980	740	181	143	6,0	5,5	1,8	1,8	4,40	1000

Is = Starting current; **Ts** = Starting torque.

The motors shown on this page are not multivoltage.

OUTPUT kW	MOTOR TYPE	PERFORMANCE AT RATED OUTPUT				DATA AT RATED VOLTAGE				MOMENT OF INERTIA J kgm ²	WEIGHT (IM 1001) Approx. kg
		SPEED n min ⁻¹	RATED CURRENT (400 V) I A		STARTING CURRENT Is/In p.u.		STARTING TORQUE Ts/Tn p.u.				

2 / 4 poles = 3000 / 1500 min⁻¹ - 50 Hz - single winding YY / Δ connection

T4, T 135°C

11	9	160 M	2880	1450	23	18,5	5,5	5,5	1,8	2,0	0,062	135
13	11,5	160 L	2890	1460	27	24	6,5	6,3	2,2	2,4	0,075	145
17	14,5	180 M	2900	1460	35	30	6,5	6,6	2,2	2,5	0,090	170
22	18,5	180 LA	2920	1460	45	37	6,5	6,0	2,2	2,2	0,110	190
24	20	180 LB	2920	1465	49	40	6,8	6,3	2,3	2,3	0,150	200
27	23,5	200 L	2920	1465	55	47	7,8	7,2	2,4	2,2	0,190	215
34	28	225 S	2930	1465	66	53	8,2	7,2	2,4	2,4	0,370	285
43	35	225 M	2930	1470	82	67	7,8	6,9	2,3	2,3	0,400	305
50	41	250 M	2930	1470	95	77	8,3	7,1	2,4	2,4	0,500	330
65	56	280 S	2940	1470	120	104	7,5	6,6	2,2	2,3	0,910	520
72	63	280 M	2940	1470	135	117	8,0	7,2	2,2	2,4	1,05	585
85	72	315 SM	2940	1470	161	139	8,0	7,2	2,2	2,4	1,15	605
93	81	315 MA	2945	1475	171	150	8,9	7,6	2,6	2,8	2,10	785
110	94	315 MC	2945	1475	198	170	8,9	8,0	2,6	2,8	2,50	860
132	110	315 MD	2945	1475	239	200	9,1	8,2	2,7	2,9	3,10	965

4 / 6 poles = 1500 / 1000 min⁻¹ - 50 Hz - two separate windings

T4, T 135°C

6,3	4,2	160 M	1475	970	13,7	11,0	6,3	5,2	2,0	2,1	0,063	135
7,9	5,4	160 L	1480	975	17,2	13,0	7,6	6,1	2,5	2,4	0,075	145
9,9	6,7	180 M	1480	975	21	16,3	7,8	6,5	2,4	2,5	0,090	165
12,3	8,6	180 LA	1480	975	24	18,3	7,4	6,8	2,3	2,3	0,160	190
14,2	9,5	180 LB	1480	975	27	20	7,4	6,8	2,1	2,3	0,220	195
17,5	11,9	200 L	1480	970	34	24	7,4	6,8	2,1	2,3	0,270	215
25	16	225 S	1475	970	46	34	7,0	6,5	2,0	2,2	0,420	275
28,5	19	225 M	1475	970	55	37	7,4	7,4	2,1	2,3	0,520	300
36	24	250 M	1480	980	67	53	7,8	7,9	2,2	2,5	0,670	345
44	30	280 S	1480	980	81	63	7,5	6,2	2,3	2,3	1,05	470
54	37	280 M	1480	980	99	72	7,6	6,8	2,3	2,5	1,25	510
63	42	315 SM	1485	980	125	91	6,5	6,2	2,0	2,2	1,43	575
70	47	315 MA	1485	985	123	86	7,9	7,0	1,9	2,3	2,60	755
85	55	315 MB	1485	980	151	98	7,9	7,6	2,2	2,5	3,00	805
103	70	315 MC	1485	980	184	126	7,4	6,9	2,1	2,3	3,60	895
112	76	315 MD	1485	985	200	138	8,1	7,1	2,3	2,4	4,45	1000

4 / 8 poles = 1500 / 750 min⁻¹ - 50 Hz - single winding YY / Δ connection

T4, T 135°C

6,3	3,6	160 MA	1460	710	12,0	9,0	6,7	4,5	2,0	2,0	0,087	130
7,5	4,4	160 MB	1460	710	14,3	10,9	6,4	4,5	1,9	2,0	0,093	135
10	5,9	160 L	1460	725	19,0	14,7	6,6	4,5	2,0	2,0	0,110	145
15	9	180 LA	1465	730	29	21	6,0	5,0	2,0	2,0	0,160	190
17,5	10,3	180 LB	1465	730	34	23	6,3	5,0	2,1	2,1	0,220	195
20	11	200 L	1465	735	39	25	6,8	6,0	2,1	2,6	0,270	215
23	15	225 S	1470	735	44	33	7,0	6,0	2,2	2,2	0,420	275
32	22	225 M	1470	735	57	49	7,0	6,0	2,2	2,2	0,570	300
38	26	250 M	1470	735	68	57	7,4	6,0	2,3	2,2	0,620	345
48	29	280 S	1475	740	85	62	6,9	5,5	2,1	2,1	1,05	510
63	37	280 M	1475	740	107	78	6,5	5,5	2,0	2,0	1,25	540
66	45	315 SM	1480	735	114	95	6,8	5,7	2,0	2,2	1,37	605
76	50	315 MA	1480	740	133	100	6,8	5,5	2,1	2,1	2,62	755
90	60	315 MB	1480	740	155	119	6,9	5,5	2,1	2,1	3,00	805
105	71	315 MC	1480	740	177	139	6,8	5,5	2,1	2,1	3,60	895
118	79	315 MD	1480	740	200	154	7,3	5,5	2,2	2,2	4,40	1000

6 / 8 poles = 1000 / 750 min⁻¹ - 50 Hz - two separate windings

T4, T 135°C

3,7	2,6	160 MA	965	710	7,6	5,7	5,5	4,5	1,7	1,7	0,087	130
4,4	3,3	160 MB	965	715	9,0	7,3	6,0	4,8	1,8	1,7	0,092	135
6	4,4	160 L	970	725	11,9	9,5	6,0	5,0	1,8	1,8	0,110	145
6,7	5	180 LA	970	730	12,7	10,8	6,7	5,5	2,0	2,0	0,160	190
9	6,5	180 LB	970	730	17,1	13,8	6,0	5,0	1,8	1,8	0,220	195
10	7,5	200 L	970	735	19,0	17,1	6,3	6,2	1,9	1,9	0,270	215
14	10,5	225 S	975	735	27	22	6,4	6,3	1,9	1,9	0,420	275
17	13,5	225 M	975	735	31	27	7,4	6,7	2,0	2,0	0,520	300
23	16	250 M	975	735	47	35	6,5	6,9	2,0	2,1	0,670	345
35	26	280 S	975	740	65	51	6,0	5,5	1,8	1,8	1,05	510
43	32	280 M	975	740	78	62	6,0	5,5	1,8	1,8	1,25	540
48	37	315 SM	980	740	87	71	6,0	5,5	1,8	1,8	2,81	605
60	45	315 MA	980	740	109	87	6,0	5,5	1,8	1,8	2,62	755
66	49	315 MB	980	740	128	100	6,4	5,8	1,9	1,9	3,00	805
71	57	315 MC	980	740	141	114	6,5	5,8	2,0	1,9	3,60	895
88	66	315 MD	980	740	181	143	6,8	6,3	2,0	2,0	4,40	1000

Is = Starting current; Ts = Starting torque.

The motors shown on this page are not multivoltage.

RATED OUTPUT kW	MOTOR TYPE	PERFORMANCE AT RATED OUTPUT					DATA AT RATED VOLTAGE			MOMENT OF INERTIA J	WEIGHT IM 1001 Approx. kg
		SPEED n	EFFICIENCY η	POWER FACTOR $\cos \varphi$	RATED CURRENT (400V) I	RATED TORQUE T _n	STARTING CURRENT I _s /I _n	STARTING TORQUE T _s /T _n	BREAKDOWN TORQUE T _{max} /T _n		
		1/min	%		A	Nm	p.u.	p.u.	p.u.		

3000 min⁻¹ = 2 poles - 50 Hz

T1 ÷ T4, T 135°C

11	160 MA2	2920	88,4	0,82	21,9	36	6,2	2,2	2,8	0,030	155
15	160 MB2	2925	89,8	0,83	29,0	49	6,4	2,2	3,0	0,035	160
18,5	160 L2	2925	90,0	0,81	36,7	60	6,8	2,3	3,0	0,040	165
22	180 M2	2930	90,5	0,84	41,8	72	6,8	2,4	3,0	0,048	188
30	200 LA2	2945	92,0	0,87	54	97	6,7	2,3	2,9	0,165	250
37	200 LB2	2945	92,2	0,87	67	120	6,9	2,4	3,0	0,180	260
45	225 M2	2960	92,5	0,88	80	145	6,6	2,4	3,0	0,225	320
55	250 M2	2960	93,0	0,87	98	177	6,7	2,4	3,0	0,250	360
75	280 S2	2960	93,6	0,87	133	242	6,8	2,3	2,7	0,350	575
90	280 M2	2960	94,2	0,88	157	290	7,2	2,3	2,7	0,416	630
110	315 SM2	2975	94,3	0,87	194	353	6,4	2,4	2,4	0,95	1050
132	315 MA2	2970	94,3	0,86	235	424	6,5	2,5	2,5	0,95	1050
160	315 MC2	2975	94,4	0,87	281	513	6,5	2,5	2,5	1,12	1115
200	315 MD2	2980	94,7	0,87	351	640	6,5	2,5	2,5	1,30	1195

1500 min⁻¹ = 4 poles - 50 Hz

T1 ÷ T4, T 135°C

11	160 M4	1455	88,6	0,81	22,1	72	5,2	2,0	2,1	0,034	165
15	160 L4	1460	89,4	0,81	29,9	98	5,8	2,2	2,4	0,075	182
18,5	180 M4	1460	90,0	0,82	36,2	121	6,2	2,3	2,5	0,090	190
22	180 L4	1465	90,5	0,84	41,8	143	6,3	2,4	2,5	0,110	240
30	200 L4	1470	91,6	0,84	56	195	6,4	2,4	2,8	0,180	270
37	225 S4	1475	92,5	0,86	67	239	6,5	2,3	2,8	0,320	325
45	225 M4	1475	92,5	0,86	82	291	6,5	2,4	2,8	0,410	342
55	250 M4	1475	93,0	0,87	98	356	6,4	2,3	2,6	0,520	410
75	280 S4	1480	93,7	0,86	134	483	7,0	2,5	2,3	0,885	608
90	280 M4	1480	93,9	0,88	157	580	7,1	2,7	2,4	1,060	665
110	315 SM4	1488	93,6	0,85	200	705	6,5	2,6	2,6	2,10	1080
132	315 MA4	1485	94,5	0,85	237	848	6,2	2,5	2,5	2,10	1080
160	315 MC4	1485	94,8	0,85	287	1028	6,2	2,5	2,5	2,50	1210
200	315 MD4	1485	95,3	0,86	353	1285	6,5	2,5	2,6	3,10	1370

1000 min⁻¹ = 6 poles - 50 Hz

T1 ÷ T4, T 135°C

7,5	160 M6	965	86,0	0,82	15,4	74	5,0	2,2	2,3	0,087	175
11	160 L6	967	88,0	0,82	22,0	108	5,5	2,3	2,5	0,110	182
15	180 L6	970	88,2	0,82	30,0	147	5,2	2,3	2,2	0,130	231
18,5	200 LA6	970	88,2	0,83	36,5	182	5,2	2,1	2,3	0,170	250
22	200 LB6	972	89,0	0,83	43	216	5,5	2,4	2,4	0,220	270
30	225 M6	975	90,5	0,84	58	294	6,2	2,4	2,4	0,470	330
37	250 M6	975	91,0	0,84	70	362	6,5	2,6	2,6	0,570	400
45	280 S6	980	92,5	0,84	84	440	6,0	2,5	2,5	0,850	560
55	280 M6	980	93,0	0,83	103	535	6,0	2,5	2,5	1,075	665
75	315 SM6	985	94,0	0,83	136	730	6,3	2,6	2,6	2,60	1000
90	315 MA6	985	94,0	0,85	163	872	6,0	2,5	2,5	2,60	1000
110	315 MB6	985	94,0	0,84	199	1065	6,0	2,5	2,5	3,00	1070
132	315 MC6	985	93,3	0,85	238	1278	6,3	2,5	2,5	3,60	1180
143	315 MD6	985	94,8	0,86	253	1385	6,3	2,5	2,5	4,40	1310

750 min⁻¹ = 8 poles - 50 Hz

T1 ÷ T4, T 135°C

4	160 MA8	710	81,0	0,73	9,8	54	4,2	1,9	2,1	0,080	140
5,5	160 MB8	720	82,4	0,74	13,0	73	4,2	1,9	2,1	0,092	151
7,5	160 L8	720	84,7	0,74	17,3	99	4,2	2,0	2,1	0,110	184
11	180 L8	725	86,7	0,75	24,4	145	4,5	2,0	2,2	0,160	255
15	200 L8	725	88,0	0,75	32,8	197	5,0	2,1	2,3	0,220	280
18,5	225 S8	730	89,0	0,76	39,5	242	5,2	2,2	2,4	0,420	324
22	225 M8	730	90,0	0,76	46,4	288	5,3	2,2	2,4	0,520	340
30	250 M8	730	91,0	0,76	63	392	5,5	2,3	2,5	0,620	405
37	280 S8	735	92,5	0,80	72	480	6,0	2,5	2,5	1,05	505
45	280 M8	735	93,0	0,80	87	569	6,0	2,5	2,5	1,25	640
55	315 SM8	740	93,5	0,82	104	709	6,5	2,3	2,4	2,8	1050
75	315 MA8	740	93,8	0,82	139	967	6,0	2,1	2,2	2,8	1050
90	315 MC8	740	94,4	0,83	166	1160	6,2	2,2	2,3	3,5	1280
110	315 MD8	740	94,5	0,83	202	1418	6,2	2,2	2,3	4,0	1370
132	315 ME8	740	94,6	0,83	243	1702	6,2	2,2	2,3	4,3	1440

I_s = Starting current, T_s = Starting torque, T_{max} = Breakdown torque.
The motors shown on this page are not multivoltage.

RATED OUTPUT kW	MOTOR TYPE	PERFORMANCE AT RATED OUTPUT				DATA AT RATED VOLTAGE				MOMENT OF INERTIA J kgm ²	WEIGHT IM 1001 Approx. kg
		SPEED		RATED CURRENT (400V) I A	STARTING CURRENT		STARTING TORQUE				
		n min ⁻¹			Is/In p.u.		Ts/Tn p.u.				

2 / 4 poles = 3000 / 1500 min⁻¹ - 50 Hz - single winding YY / Δ connection

T1 ÷ T3, T 150°C

11 14	9 12	160 M 160 L	2880 2890	1450 1460	22,8 27,6	18,5 23,8	5,5 6,0	5,5 6,0	1,8 2,0	2,0 2,3	0,062 0,075	165 180
18,5 22 25	16 18,5 21	180 M 180 LA 180 LB	2900 2920 2920	1460 1460 1465	36,1 42,8 48,5	31,4 35,2 40,0	6,0 6,5 6,5	6,0 6,0 6,0	2,0 2,2 2,2	2,3 2,2 2,2	0,090 0,110 0,150	190 240 250
30	26	200 L	2920	1465	58	49	7,0	6,5	2,2	2,0	0,190	270
37 45	31 37	225 S 225 M	2930 2930	1465 1470	68 82	56 67	7,5 7,5	6,5 6,5	2,2 2,2	2,2 2,2	0,370 0,400	325 340
55	45	250 M	2930	1470	100	81	7,5	6,5	2,2	2,2	0,500	360
70 80	59 70	280 S 280 M	2940 2940	1470 1470	124 143	105 124	7,0 7,2	6,3 6,5	2,0 2,0	2,2 2,2	0,910 1,050	615 675
95 110 130 160	80 95 110 132	315 SM 315 MA 315 MC 315 MD	2940 2945 2945 2945	1470 1475 1475 1475	171 193 223 276	147 167 190 228	7,2 7,5 7,5 7,5	6,5 6,5 6,8 6,8	2,0 2,2 2,2 2,4	2,2 2,4 2,4 2,4	1,15 2,10 2,50 3,10	1080 1085 1210 1375

4 / 6 poles = 1500 / 1000 min⁻¹ - 50 Hz - two separate windings

T1 ÷ T3, T 150°C

6,6 8,8	4,4 6	160 M 160 L	1470 1475	965 970	12,8 17,1	9,0 12,4	6,0 6,5	5,0 5,5	1,9 2,2	2,0 2,2	0,063 0,075	165 180
11 13 15	7,5 9 10	180 M 180 LA 180 LB	1475 1475 1475	970 970 970	20,9 24,7 28,5	15,2 18,1 20,0	6,8 7,0 7,0	5,8 6,5 6,5	2,2 2,2 2,0	2,2 2,2 2,2	0,090 0,160 0,220	190 215 225
18,5	12,5	200 L	1475	970	35	25	7,0	6,5	2,0	2,2	0,270	245
25 30	16 20	225 S 225 M	1475 1475	970 970	43 52	28 36	6,5 7,0	6,5 7,0	2,0 2,0	2,2 2,2	0,420 0,520	310 335
40	27	250 M	1480	975	73	50	7,0	7,0	2,0	2,2	0,670	410
51 63	34 42	280 S 280 M	1480 1480	980 980	93 114	62 76	6,5 6,5	6,0 6,0	2,0 2,0	2,2 2,2	1,050 1,250	565 600
70 85 103 118 140	47 55 70 80 90	315 SM 315 MA 315 MB 315 MC 315 MD	1480 1480 1480 1480 1480	980 980 980 980 980	124 147 181 209 247	86 100 124 143 162	6,5 6,5 6,5 6,5 6,5	6,2 6,0 6,0 6,0 6,0	2,0 1,6 1,8 2,0 1,8	2,2 2,0 2,0 2,0 2,0	1,43 2,60 3,00 3,60 4,45	1000 1005 1070 1180 1310

4 / 8 poles = 1500 / 750 min⁻¹ - 50 Hz - single winding YY / Δ connection

T1 ÷ T3, T 150°C

7 8 11	4 5 6,5	160 MA 160 MB 160 L	1460 1460 1460	710 715 725	13,3 15,2 20,9	10,0 12,4 16,2	6,0 6,0 6,0	4,5 4,5 4,5	1,8 1,8 1,8	1,8 1,8 1,8	0,087 0,093 0,110	175 175 195
15 18,5	9 11	180 LA 180 LB	1465 1465	730 730	28,5 36,1	20,9 24,7	6,0 6,0	5,0 5,0	2,0 2,0	2,0 2,0	0,160 0,220	255 260
21	13	200 L	1465	735	41	29	6,5	6,0	2,0	2,2	0,270	285
23 32	15 22	225 S 225 M	1470 1470	735 735	44 57	33 49	7,0 7,0	6,0 6,0	2,2 2,2	2,2 2,2	0,420 0,570	325 340
40	26	250 M	1470	735	71	57	7,0	6,0	2,2	2,2	0,620	405
51 63	31 37	280 S 280 M	1475 1475	740 740	90 107	67 78	6,5 6,5	5,5 5,5	2,0 2,0	2,0 2,0	1,050 1,250	610 645
66 80 95 110 132	45 52 63 75 88	315 SM 315 MA 315 MB 315 MC 315 MD	1480 1480 1480 1480 1480	735 740 740 740 740	114 140 163 185 223	95 105 125 147 171	6,8 6,5 6,5 6,5 6,5	5,7 5,5 5,5 5,5 5,5	2,0 2,0 2,0 2,0 2,0	2,2 2,0 2,0 2,0 2,0	1,37 2,62 3,00 3,60 4,40	1040 1040 1070 1185 1315

6 / 8 poles = 1000 / 750 min⁻¹ - 50 Hz - two separate windings

T1 ÷ T3, T 150°C

3,7 4,4 6	2,6 3,3 4,4	160 MA 160 MB 160 L	965 965 970	710 715 725	7,6 9,0 11,9	5,7 7,3 9,5	5,5 6,0 6,0	4,5 4,8 5,0	1,7 1,8 1,8	1,7 1,7 1,8	0,087 0,092 0,110	175 180 195
7,5 9	5,5 6,5	180 LA 180 LB	970 970	730 730	14,3 17,1	11,9 13,8	6,0 6,0	5,0 5,0	1,8 1,8	1,8 1,8	0,160 0,220	255 260
10,5	8	200 L	970	735	20	17	6,0	5,8	1,8	1,8	0,270	285
15 19	11 15	225 S 225 M	975 975	735 735	28 35	23 20	6,0 6,0	6,0 6,0	1,8 1,8	1,8 1,8	0,420 0,520	325 340
25	18,5	250 M	975	735	51	41	6,0	6,0	1,8	1,8	0,670	405
35 43	26 32	280 S 280 M	975 975	740 740	65 78	51 62	6,0 6,0	5,5 5,5	1,8 1,8	1,8 1,8	1,050 1,250	610 645
48 60 70 77 100	37 45 52 60 75	315 SM 315 MA 315 MB 315 MC 315 MD	980 980 980 980 980	740 740 740 740 740	87 109 128 141 181	71 87 100 114 143	6,0 6,0 6,0 6,0 6,0	5,5 5,5 5,5 5,5 5,5	1,8 1,8 1,8 1,8 1,8	1,8 1,8 1,8 1,8 1,8	2,81 2,62 3,00 3,60 4,40	1040 1040 1070 1185 1315

Is = Starting current; Ts = Starting torque.

The motors shown on this page are not multivoltage.

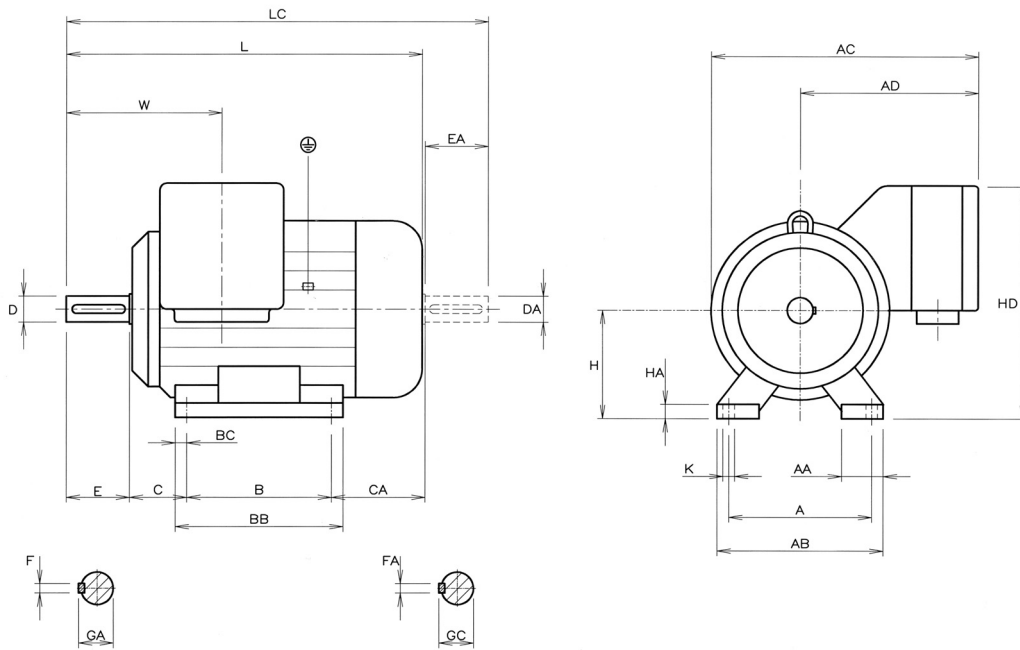

FRAME SIZE	A	AA	AB	AC	AD	B	BB	BC	C	CA	H	HA	HD	K
71	112	26	135	255	175	90	110	10	45	104	71	8	161	7
80	125	25	150	275	185	100	125	12,5	50	112	80	8	180	9
90	S	140	30	175	312	100	125	12,5	56	111	90	10	206	9
	L	140	30	175	302	125	150	12,5	56	126	90	10	206	9
100	L	160	31	195	336	140	170	15	63	138	100	12	240	12
112	M	190	39	225	336	140	170	15	70	171	112	12	252	12
132	S	216	41	255	386	140	185	22,5	89	168	132	15	273	12
	M	216	41	255	386	178	223	22,5	89	168	132	15	273	12

FRAME SIZE	L	LD	LC	W	SHAFT EXTENSION								
					D	E	F	GA	DA	EA	FA	GC	
71	266	297	299	120	14	30	5	16	14	30	5	16	
80	299	330	342	130	19	40	6	21,5	19	40	6	21,5	
90	S	314	345	367	142	24	50	8	27	24	50	8	27
	L	354	385	407	142	24	50	8	27	24	50	8	27
100	L	397	425	461	162	28	60	8	31	28	60	8	31
112	M	437	468	501	172	28	60	8	31	28	60	8	31
132	S	473	504	557	202	38	80	10	41	38	80	10	41
	M	511	542	595	202	38	80	10	41	38	80	10	41

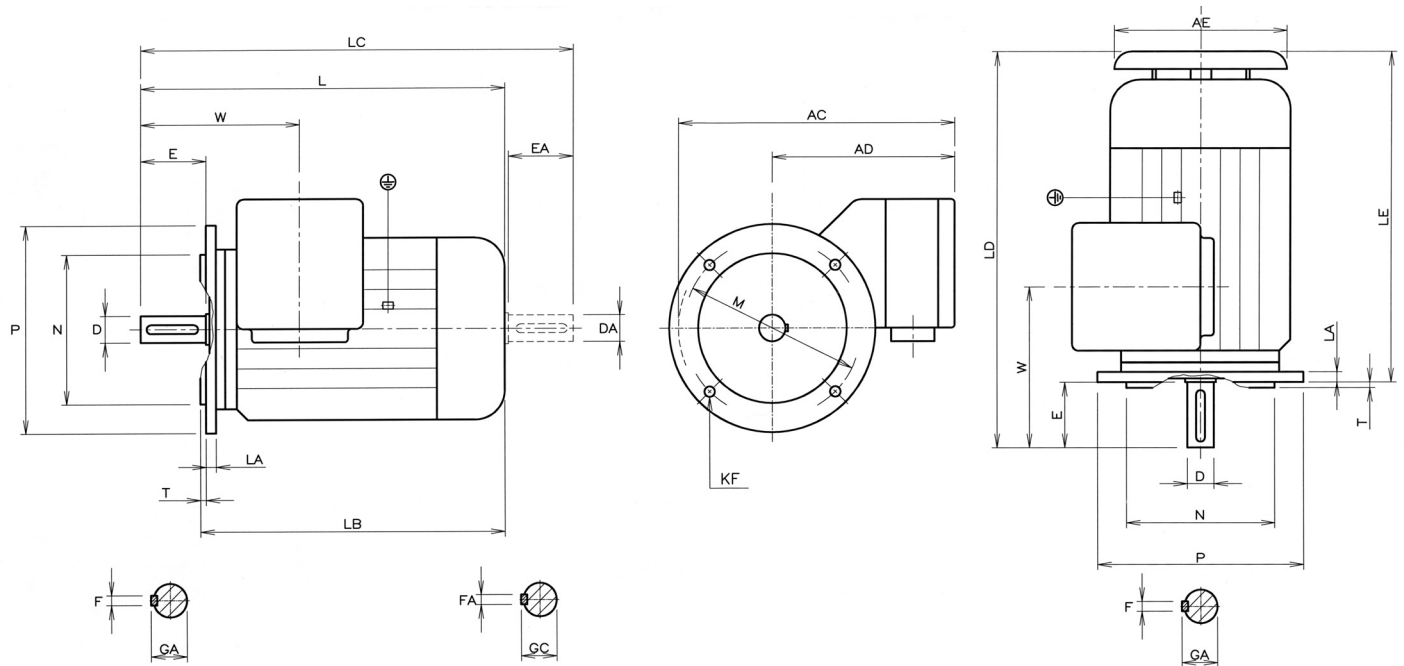

FRAME SIZE	AC	AD	AE	L	LB	LC	LD	W	LE	SHAFT EXTENSION								
										D	E	F	GA	DA	EA	FA	GC	
71	255	175	125	266	239	299	297	120	267	14	30	5	16	14	30	5	16	
80	275	185	182	299	262	342	330	130	290	19	40	6	21,5	19	40	6	21,5	
90	S	304	192	182	314	267	367	345	142	295	24	50	8	27	24	50	8	27
	L	304	192	182	354	307	407	328	142	335	24	50	8	27	24	50	8	27
100	L	336	214	212	397	341	461	428	172	368	28	60	8	31	28	60	8	31
112	M	336	214	212	437	381	501	468	172	408	28	60	8	31	28	60	8	31
132	S	386	236	264	473	397	557	504	202	424	38	80	10	41	38	80	10	41
	M	386	236	264	511	435	595	542	202	462	38	80	10	41	38	80	10	41

FRAME SIZE	FLANGE B5						
	M	N	P	LA	KF	T	
71	130	110	160	6	9,5	3,5	
80	165	130	200	9	11,5	3,5	
90	S	165	130	200	9	11,5	3,5
	L	165	130	200	9	11,5	3,5
100	L	215	180	250	14	14,0	4
112	M	215	180	250	14	14,0	4
132	S	265	230	300	14	14,0	4
	M	265	230	300	14	14,0	4

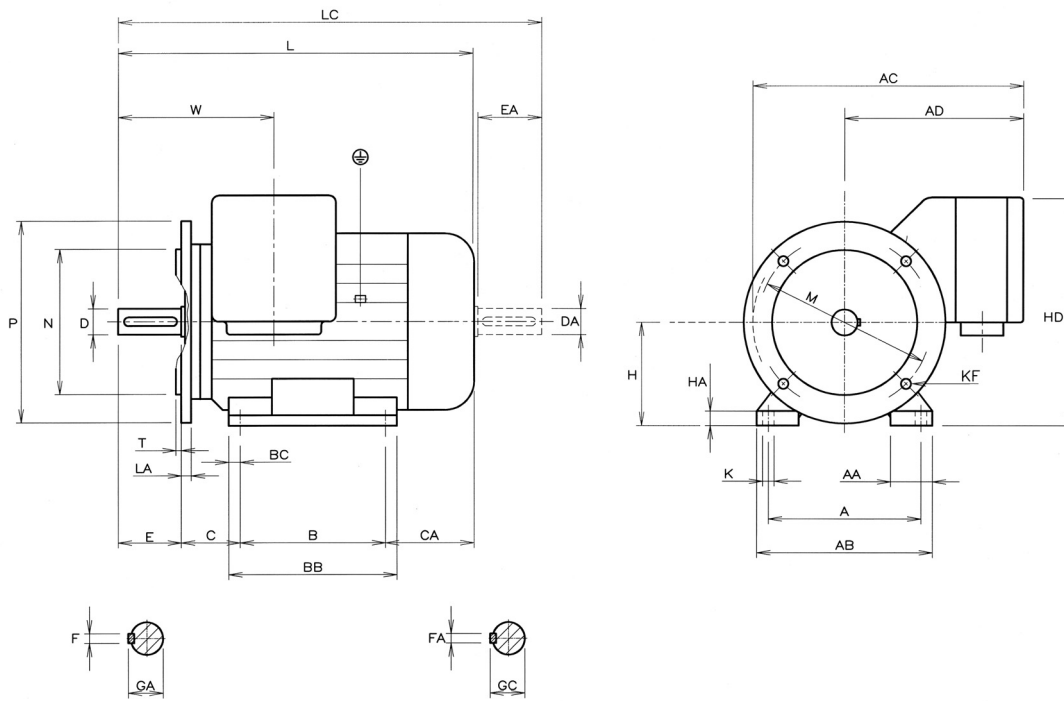

FRAME SIZE	A	AA	AB	AC	AD	B	BB	BC	C	CA	H	HA	HD	K
71	112	26	135	255	175	90	110	10	45	104	71	8	161	7
80	125	25	150	275	185	100	125	12,5	50	112	80	8	180	9
90	S	140	30	175	312	100	125	12,5	56	111	90	10	206	9
	L	140	30	175	302	125	150	12,5	56	126	90	10	206	9
100	L	160	31	195	336	140	170	15	63	138	100	12	240	12
112	M	190	39	225	336	140	170	15	70	171	112	12	252	12
132	S	216	41	255	386	140	185	22,5	89	168	132	15	273	12
	M	216	41	255	386	178	223	22,5	89	168	132	15	273	12

FRAME SIZE	L	LD	LC	W	FLANGE B5						SHAFT EXTENSION								
					M	N	P	LA	KF	T	D	E	F	GA	DA	EA	FA	GC	
71	266	297	299	120	130	110	160	6	9,5	3,5	14	30	5	16	14	30	5	16	
80	299	330	342	130	165	130	200	9	11,5	3,5	19	40	6	21,5	19	40	6	21,5	
90	S	314	345	367	142	165	130	200	9	11,5	3,5	24	50	8	27	24	50	8	27
	L	354	385	407	142	165	130	200	9	11,5	3,5	24	50	8	27	24	50	8	27
100	L	397	425	461	162	215	180	250	14	14,0	4	28	60	8	31	28	60	8	31
112	M	437	468	501	172	215	180	250	14	14,0	4	28	60	8	31	28	60	8	31
132	S	473	504	557	202	265	230	300	14	14,0	4	38	80	10	41	38	80	10	41
	M	511	542	595	202	265	230	300	14	14,0	4	38	80	10	41	38	80	10	41

DIMENSIONS D5 71-112 IM B14 AND IM V18

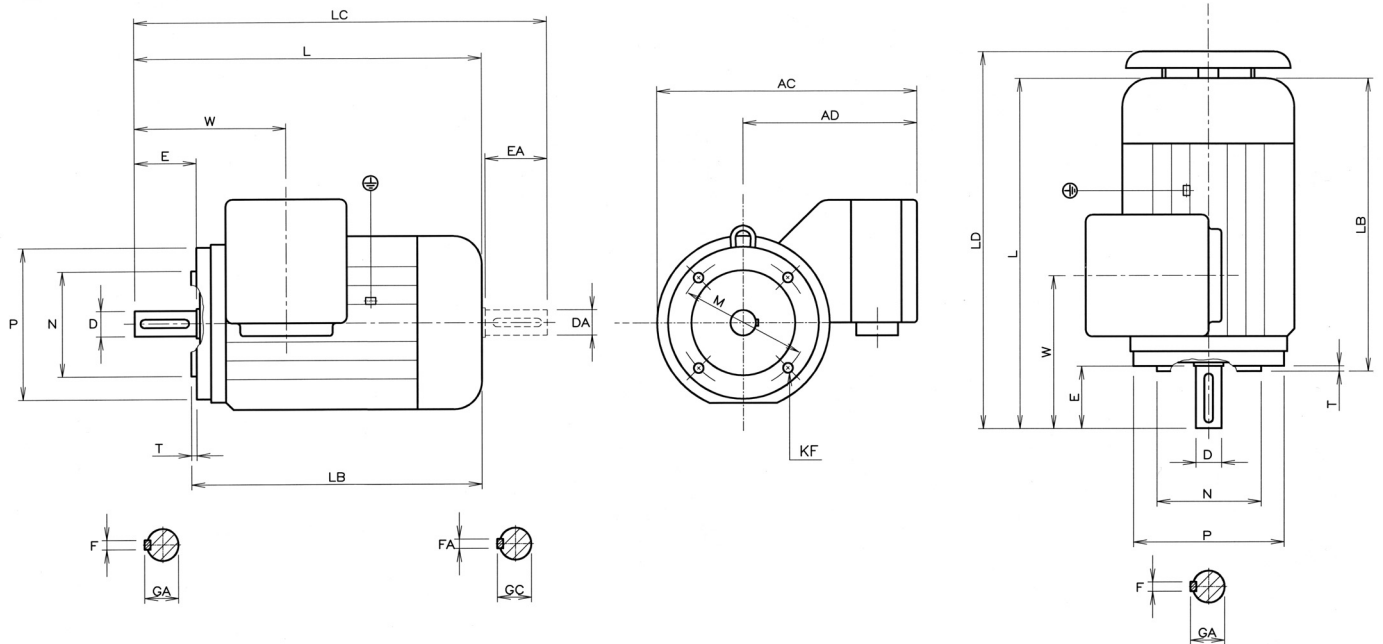

FRAME SIZE	AC	AD	AE	L	LB	LC	LD	W	FLANGE B14				
									M	N	P	KF	T
71	255	175	125	266	239	299	297	120	85	70	105	M6	2,5
80	275	185	182	299	262	342	330	130	100	80	120	M6	3,0
90	S	304	192	182	314	367	345	142	115	95	140	M8	3,0
	L	304	192	182	354	407	328	142	115	95	140	M8	3,0
100	L	336	214	212	397	461	428	172	130	110	160	M8	3,5
112	M	336	214	212	437	501	468	172	130	110	160	M8	3,5

FRAME SIZE	SHAFT EXTENSION										
	D	E	F	GA	DA	GA	DA	EA	FA	GC	
71	14	30	5	16	14	16	14	30	5	16	
80	19	40	6	21,5	19	21,5	19	40	6	21,5	
90	S	24	50	8	27	24	27	24	50	8	27
	L	24	50	8	27	24	27	24	50	8	27
100	L	28	60	8	31	28	31	28	60	8	31
112	M	28	60	8	31	28	31	28	60	8	31

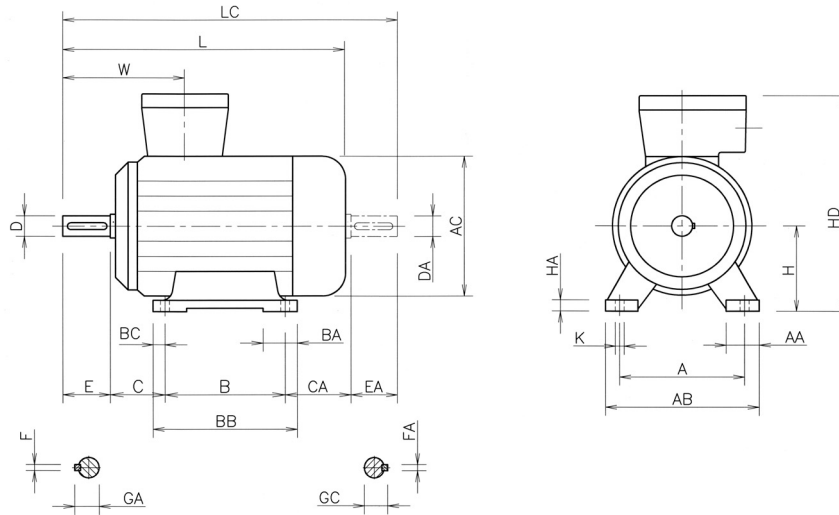

FRAME SIZE	POLES	A	AA	AB	AC	B	BA	BB	BC	C	CA	H	HA	HD	K	L	
D5_160	M	2-8	254	55	300	314	210	95	296	21	108	223	160	22	446	14	648
	L		254	55	300	314	254	95	296	21	108	179	160	22	446	14	648
D5_180	M	2-4	279	58	324	314	241	65	283	21	121	179	180	24	466	14	648
	L	4-8	279	58	324	354	279	90	321	21	121	216	180	24	488	14	723
D5_200	L	2-8	318	63	368	354	305	75	350	22,5	133	178	200	24	508	18	723
D5_225	S	4-8	356	76	406	411	286	100	360	24,5	149	260	225	28	593	18	830
	M	2	356	76	406	411	311	100	360	24,5	149	235	225	28	593	18	800
		4-8	356	76	406	411	311	100	360	24,5	149	235	225	28	593	18	830
D5_250	M	2	406	90	465	411	349	95	406	28,5	168	178	250	28	618	22	830
		4-8	406	90	465	411	349	95	406	28,5	168	178	250	28	618	22	830
D5_280	S	2	457	90	540	490	368	110	480	30,5	190	272	280	40	710	22	960
		4-8	457	90	540	490	368	110	480	30,5	190	272	280	40	710	22	960
	M	2	457	90	540	490	419	110	480	30,5	190	221	280	40	710	22	960
		4-8	457	90	540	490	419	110	480	30,5	190	221	280	40	710	22	960
D5_315	SM	2	508	110	590	604	457	165	520	32	216	299	315	45	820	27	1102
	SM	4-8	508	110	590	604	457	165	520	32	216	299	315	45	820	27	1132
	MA	2	508	110	590	604	457	165	520	32	216	299	315	45	820	27	1102
	MA-MC	4-8	508	110	590	604	457	165	520	32	216	299	315	45	820	27	1132
	MD	2	508	110	590	604	457	165	520	32	216	299	315	45	820	27	1102
	MD-ME	4-8	508	110	590	604	457	165	520	32	216	299	315	45	820	27	1132

FRAME SIZE	POLES	LC	W	SHAFT EXTENSION								
				D	E	F	GA	DA	EA	FA	GC	
D5_160	M	2-8	761	279	42	110	12	45	42	110	12	45
	L		761	279	42	110	12	45	42	110	12	45
D5_180	M	2-4	761	279	48	110	14	51,5	42	110	12	45
	L	4-8	836	296	48	110	14	51,5	42	110	12	45
D5_200	L	2-8	836	296	55	110	16	59	42	110	12	45
D5_225	S	4-8	945	318	60	140	18	64	55	110	16	59
	M	2	915	288	55	110	16	59	55	110	16	59
		4-8	945	318	60	140	18	64	55	110	16	59
D5_250	M	2	945	318	60	140	18	64	55	110	16	59
		4-8	945	318	65	140	18	69	55	110	16	59
D5_280	S	2	1110	350	65	140	18	69	60	140	18	64
		4-8	1110	350	75	140	20	79,5	60	140	18	64
	M	2	1110	350	65	140	18	69	60	140	18	64
		4-8	1110	350	75	140	20	79,5	60	140	18	64
D5_315	SM	2	1252	387	65	140	18	69	60	140	18	64
	SM	4-8	1282	417	80	170	22	85	65	140	18	69
	MA	2	1252	387	65	140	18	69	60	140	18	64
	MA-MC	4-8	1282	417	80	170	22	85	65	140	18	69
	MD	2	1252	387	70	140	20	74,5	60	140	18	64
	MD-ME	4-8	1282	417	90	170	25	95	65	140	18	69

Dimensions not valid for IIC motors.

DIMENSIONS D5 160-315 IM B5 AND IM V1

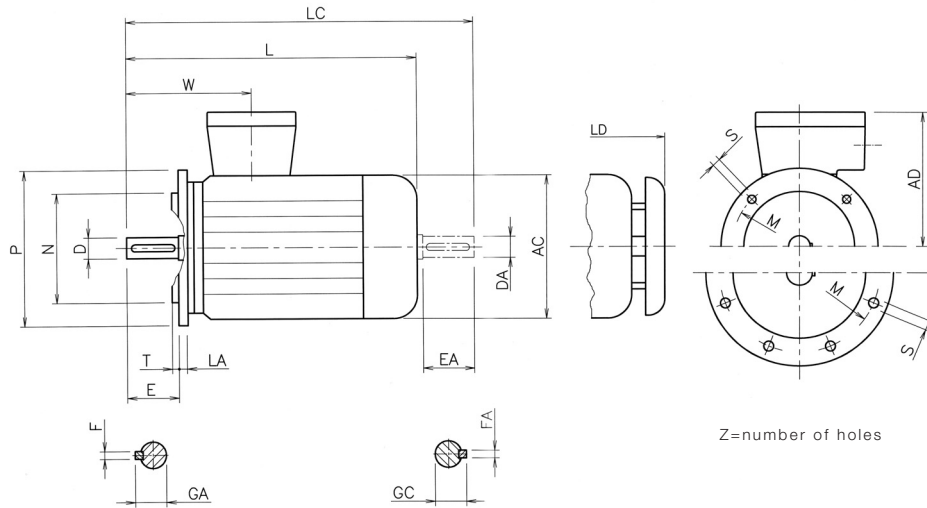

FRAME SIZE	POLES	AC	AD	L	LC	LD	W	SHAFT EXTENSION								
								D	E	F	GA	DA	EA	FA	GC	
D5_160	M	2-8	314	286	648	761	710	279	42	110	12	45	42	110	12	45
	L		314	286	648	761	710	279	42	110	12	45	42	110	12	45
D5_180	M	2-4	314	286	648	761	710	279	48	110	14	51,5	42	110	12	45
	L	4-8	354	308	723	836	790	296	48	110	14	51,5	42	110	12	45
D5_200	L	2-8	354	308	723	836	790	296	55	110	16	59	42	110	12	45
D5_225	S	4-8	411	368	830	945	895	318	60	140	18	64	55	110	16	59
	M	2	411	368	800	915	865	288	55	110	16	59	55	110	16	59
		4-8	411	368	830	945	895	318	60	140	18	64	55	110	16	59
D5_250	M	2	411	368	830	945	895	318	60	140	18	64	55	110	16	59
		4-8	411	368	830	945	895	318	65	140	18	69	55	110	16	59
	S	2	490	430	960	1110	1045	350	65	140	18	69	60	140	18	64
D5_280	S	4-8	490	430	960	1110	1045	350	75	140	20	79,5	60	140	18	64
		2	490	430	960	1110	1045	350	65	140	18	69	60	140	18	64
	M	4-8	490	430	960	1110	1045	350	75	140	20	79,5	60	140	18	64
		2	490	430	960	1110	1045	350	65	140	18	69	60	140	18	64
D5_315	SM	2	604	505	1102	1252	1177	387	65	140	18	69	60	140	18	64
	SM	4-8	604	505	1132	1282	1207	417	80	170	22	85	65	140	18	69
	MA	2	604	505	1102	1252	1177	387	65	140	18	69	60	140	18	64
	MA-MC	4-8	604	505	1132	1282	1207	417	80	170	22	85	65	140	18	69
	MD	2	604	505	1102	1252	1177	387	70	140	20	74,5	60	140	18	64
	MD-ME	4-8	604	505	1132	1282	1207	417	90	170	25	95	65	140	18	69

FRAME SIZE	POLES	FLANGE							
		LA	M	N	P	S	T	Z	
D5_160	M	2-8	15	300	250	350	18	5	4
	L		15	300	250	350	18	5	4
D5_180	M	2-4	15	300	250	350	18	5	4
	L	4-8	15	300	250	350	18	5	4
D5_200	L	2-8	18	350	300	400	18	5	4
D5_225	S	4-8	16	400	350	450	18	5	8
	M	2	16	400	350	450	18	5	8
		4-8	16	400	350	450	18	5	8
D5_250	M	2	18	500	450	550	18	5	8
		4-8	18	500	450	550	18	5	8
	S	2	18	500	450	550	18	5	8
D5_280	S	4-8	18	500	450	550	18	5	8
		2	18	500	450	550	18	5	8
	M	4-8	18	500	450	550	18	5	8
		2	18	500	450	550	18	5	8
D5_315	SM	2	22	600	550	660	22	6	8
	SM	4-8	22	600	550	660	22	6	8
	MA	2	22	600	550	660	22	6	8
	MA-MC	4-8	22	600	550	660	22	6	8
	MD	2	22	600	550	660	22	6	8
	MD-ME	4-8	22	600	550	660	22	6	8

Dimensions not valid for IIC motors.

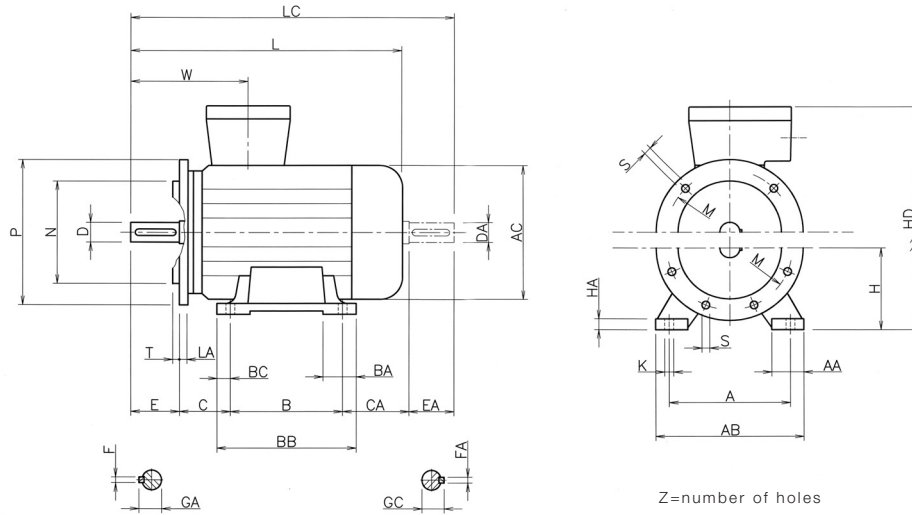

FRAME SIZE	POLES	A	AA	AB	AC	B	BA	BB	BC	C	CA	H	HA	HD	K	L	LC	
D5_160	M	2-8	254	55	300	314	210	95	296	21	108	223	160	22	446	14	648	761
	L		254	55	300	314	254	95	296	21	108	179	160	22	446	14	648	761
D5_180	M	2-4	279	58	324	314	241	65	283	21	121	179	180	24	466	14	648	761
	L	4-8	279	58	324	354	279	90	321	21	121	216	180	24	488	14	723	836
D5_200	L	2-8	318	63	368	354	305	75	350	22,5	133	178	200	24	508	18	723	836
D5_225	S	4-8	356	76	406	411	286	100	360	24,5	149	260	225	28	593	18	830	945
		2	356	76	406	411	311	100	360	24,5	149	235	225	28	593	18	800	915
	M	4-8	356	76	406	411	311	100	360	24,5	149	235	225	28	593	18	830	945
D5_250	M	2	406	90	465	411	349	95	406	28,5	168	178	250	28	618	22	830	945
		4-8	406	90	465	411	349	95	406	28,5	168	178	250	28	618	22	830	945
D5_280	S	2	457	90	540	490	368	110	480	30,5	190	272	280	40	710	22	960	1110
		4-8	457	90	540	490	368	110	480	30,5	190	272	280	40	710	22	960	1110
	M	2	457	90	540	490	419	110	480	30,5	190	221	280	40	710	22	960	1110
		4-8	457	90	540	490	419	110	480	30,5	190	221	280	40	710	22	960	1110
D5_315	SM	2	508	110	590	604	457	165	520	32	216	299	315	45	820	27	1102	1252
	SM	4-8	508	110	590	604	457	165	520	32	216	299	315	45	820	27	1132	1282
	MA	2	508	110	590	604	457	165	520	32	216	299	315	45	820	27	1102	1252
	MA-MC	4-8	508	110	590	604	457	165	520	32	216	299	315	45	820	27	1132	1282
	MD	2	508	110	590	604	457	165	520	32	216	299	315	45	820	27	1102	1252
	MD-ME	4-8	508	110	590	604	457	165	520	32	216	299	315	45	820	27	1132	1282

FRAME SIZE	POLES	W	SHAFT EXTENSION									FLANGE						
			D	E	F	GA	DA	EA	FA	GC	LA	M	N	P	S	T	Z	
D5_160	M	2-8	279	42	110	12	45	42	110	12	45	15	300	250	350	18	5	4
	L		279	42	110	12	45	42	110	12	45	15	300	250	350	18	5	4
D5_180	M	2-4	279	48	110	14	51,5	42	110	12	45	15	300	250	350	18	5	4
	L	4-8	296	48	110	14	51,5	42	110	12	45	15	300	250	350	18	5	4
D5_200	L	2-8	296	55	110	16	59	42	110	12	45	18	350	300	400	18	5	4
D5_225	S	4-8	318	60	140	18	64	55	110	16	59	16	400	350	450	18	5	8
		2	288	55	110	16	59	55	110	16	59	16	400	350	450	18	5	8
	M	4-8	318	60	140	18	64	55	110	16	59	16	400	350	450	18	5	8
D5_250	M	2	318	60	140	18	64	55	110	16	59	18	500	450	550	18	5	8
		4-8	318	65	140	18	69	55	110	16	59	18	500	450	550	18	5	8
D5_280	S	2	350	65	140	18	69	60	140	18	64	18	500	450	550	18	5	8
		4-8	350	75	140	20	79,5	60	140	18	64	18	500	450	550	18	5	8
	M	2	350	65	140	18	69	60	140	18	64	18	500	450	550	18	5	8
D5_315	SM	2	387	65	140	18	69	60	140	18	64	22	600	550	660	22	6	8
		4-8	417	80	170	22	85	65	140	18	69	22	600	550	660	22	6	8
	MA	2	387	65	140	18	69	60	140	18	64	22	600	550	660	22	6	8
	MA-MC	4-8	417	80	170	22	85	65	140	18	69	22	600	550	660	22	6	8
	MD	2	387	70	140	20	74,5	60	140	18	64	22	600	550	660	22	6	8
MD-ME	4-8	417	90	170	25	95	65	140	18	69	22	600	550	660	22	6	8	

Dimensions not valid for IIC motors.

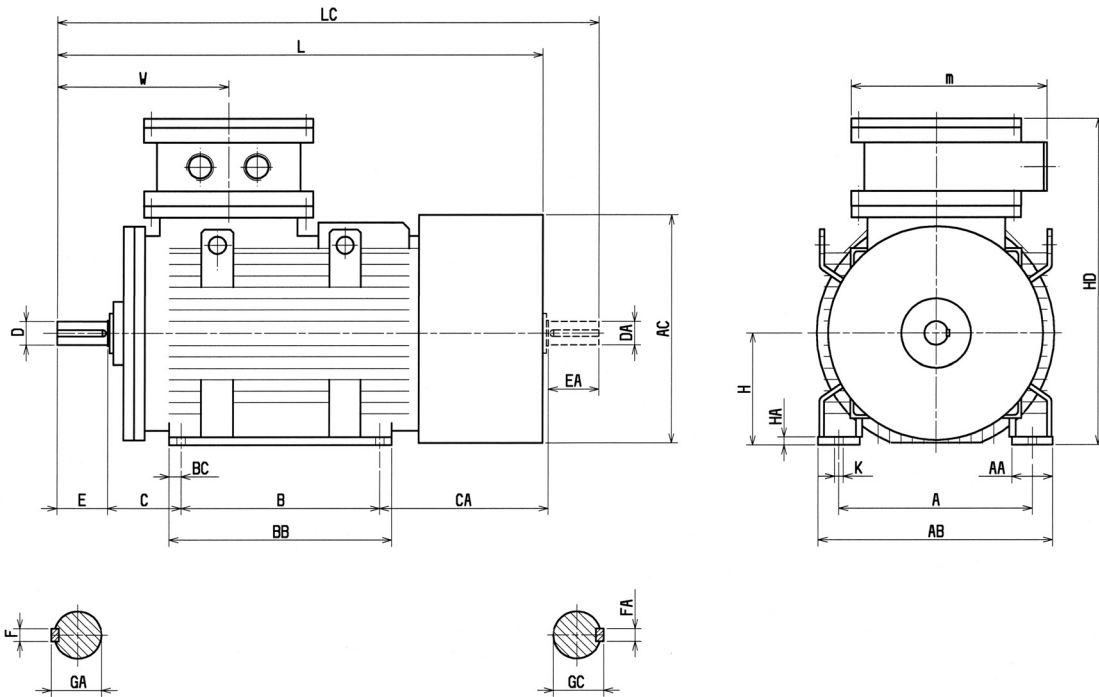

FRAME SIZE		POLES	A	AA	AB	AC	AD	AE	B	BB	BC	C	CA	H	HA	HD	K	L	LC	W
D5_355	L	2	610	130	740	750	695	755	630	706	38	254	526	355	26	1050	27	1550	1695	550
		4-8	610	130	740	750	695	755	630	706	38	254	596	355	26	1050	27	1620	1765	620
D5_400	LX - LW - LY	2	686	150	836	805	730	820	710	880	85	280	655	400	35	1130	33	1780	1925	580
	LZ		686	150	836	805	730	820	710	1025	85	280	755	400	35	1130	33	1880	2025	580
	LX - LW - LY	4-8	686	150	836	805	730	820	710	880	85	280	655	400	35	1130	33	1850	1995	650
	LZ		686	150	836	805	730	820	710	1025	85	280	755	400	35	1130	33	1950	2095	650

FRAME SIZE	POLES	SHAFT EXTENSION								
		D	E	F	GA	DA	EA	FA	GC	
D5_355	L	2	75	140	20	79,5	75	140	20	79,5
		4-8	100	210	29	106	75	140	20	79,5
D5_400	L	2	75	140	20	79,5	75	140	20	79,5
		4-8	100	210	28	106	75	140	20	79,5

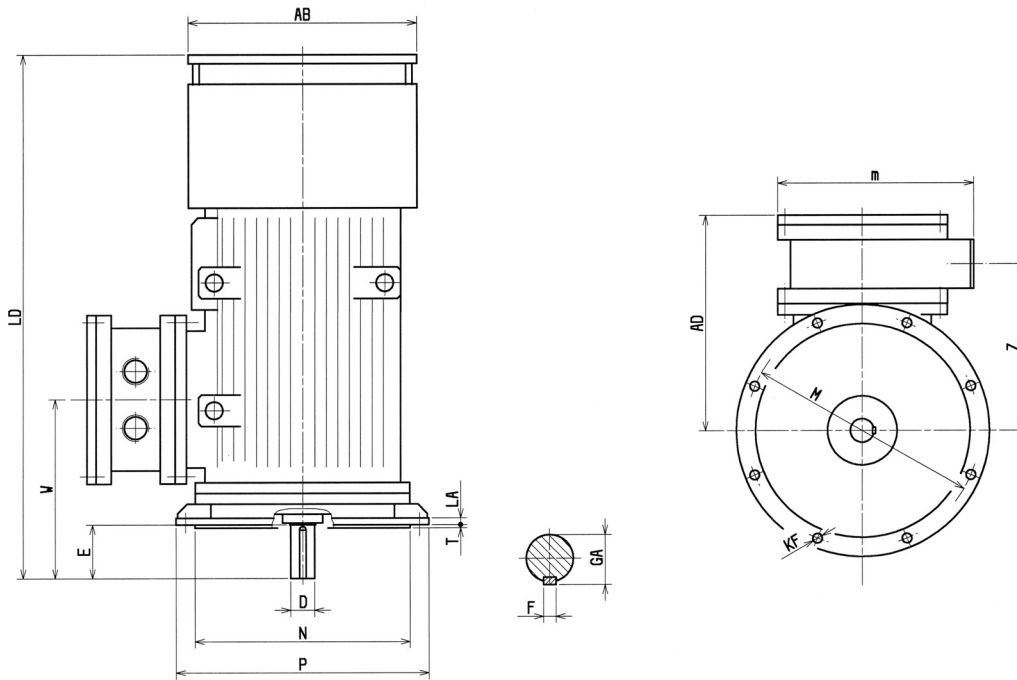

FRAME SIZE	POLES	AB	AD	LD	m	Z	W	SHAFT EXTENSION				
								D	E	F	GA	
D5_355	L	2	755	695	1655	618	528	550	75	140	20	79,5
		4-8	755	695	1725	618	528	620	100	210	29	106
D5_400	LX - LW - LY	2	820	730	1880	618	578	580	75	140	20	79,5
			LZ	820	730	1980	618	578	580	75	140	20
	LX - LW - LY	4-8	820	730	1950	618	578	650	100	210	28	106
			LZ	820	730	2000	618	578	650	100	210	28

FRAME SIZE	POLES	FLANGE						
		M	N	P	LA	KF	T	
D5_355	L	2	740	680	800	25	n°8x24	6
		4-8	740	680	800	25	n°8x24	6
D5_400	L	2	940	880	1000	26	n°8x28	6
		4-8	940	880	1000	26	n°8x28	6

HEADQUARTERS
Marelli Motori S.p.A.

Via Sabbionara, 1
36071 Arzignano (VI) Italy
(T) +39.0444.479.711
(F) +39.0444.479.888

www.marellimotori.com

✉ sales@marellimotori.com

ITALIAN OFFICES
Milan

Via Cesare Cantù, 29
20092 Cinisello Balsamo (MI) Italy
(T) +39.02.660.131.66
(F) +39.02.660.134.83

✉ milan@marellimotori.com

Florence

Via Panciatici, 37/2
50127 Firenze - Italy
(T) +39.055.431.838
(F) +39.055.433.351

✉ florence@marellimotori.com

MARELLIMOTORI OVERSEAS OFFICES:
GREAT BRITAIN

Marelli UK Ltd
Meadow Lane
Loughborough
Leicester
LE 11 1NB - UK
(P) +44.1509.615518
(F) +44.1509.615514
✉ uk@marellimotori.com

GERMANY

Marelli Central Europe GmbH
Heilswannenweg 50
31008 Elze - Germany
(P) +49.5068.462-400
(F) +49.5068.462-409
✉ germany@marellimotori.com

USA

Marelli USA, Inc
1620 Danville Road
PO Box 410
Harrodsburg, KY 40330 - USA
(P) +1.859.734-2588
(F) +1.859.734-0629
✉ usa@marellimotori.com

MALAYSIA

Marelli Asia Pacific Sdn Bhd
Lot 7, Jalan Majistret U1/26
Hicom - Glenmarie Industrial Park
40150 Shah Alam
Selangor D.E., Malaysia
(P) +60.3.7805.3736
(F) +60.3.7803.9625
✉ asiapacific@marellimotori.com

SOUTH AFRICA

Marelli Electrical Machines South Africa (Pty) Ltd
Unit 4
55 Activia Rd-Activia Park
Elandsfontein, 1406
Gauteng
Republic of South Africa
(P) +27.11.822.5566
(F) +27.11.828.8089
✉ southafrica@marellimotori.com